

WHEN DISASSEMBLING ALUMINUM EXTRUSION, TIGHTEN ALL SETSCREWS AND LOCKS TO PREVENT LOSS DURING SHIPPING

visionary™ IDESIGNS

Using Your Setup Instructions

The Visionary Designs Setup Instructions are created specifically for your configuration. They are laid out sequentially, including an exploded view of the entire display, and then a logical series of detailed steps to assemble the main structure and components. We encourage you to study the instructions **before** attempting to assemble your exhibit.

Each page reminds you to tighten the setscrews after disassembling your exhibit to prevent loss of the locks and setscrews (see below in RED). This is **VERY IMPORTANT**.

Cleaning and Packing Your Display

- 1) Use care when cleaning aluminum extrusion or acrylic inserts. Use only non-abrasive cleaners.
- 2) When cleaning laminate inserts or countertops, use mild cleansers and a soft material such as cotton.
- 3) Keep all display components away from extreme heat and long exposure to sunlight to avoid warping and fading.
- 4) Retain all packing material. It will make re-packing much easier and will reduce the likelihood of shipping damage.



The Tool

Most Visionary Designs exhibits can be assembled with the supplied Hex Key Tool. Occasionally, a flat head screwdriver may be required.



Typical Connection

Most horizontal extrusion connections have a patented expandable lock. This lock inserts into the groove of an opposing extrusion. Tightening the lock with the Hex Key Tool expands the lock and creates a strong positive connection.



Typical Connection (cont'd)



Detail B

Numbered Label

Each extrusion contains a numbered label which corresponds with setup instructions. The label is located within a groove of the extrusion (when possible). With Visionary Designs the labels contain Black numbers unless otherwise specified.



Detail C

Horizontal Inline Connection (remove only one setscrew)

Remove only (1) setscrew when disassembling. Replace setscrew in extrusion after assembling it. Before packing, replace setscrew in extrusion to avoid losing it.

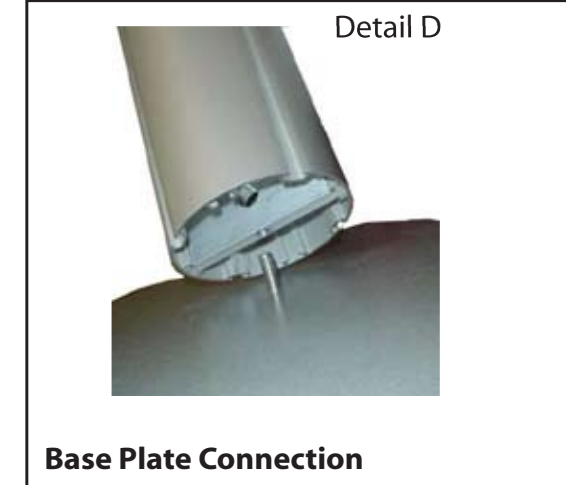

Detail D

Base Plate Connection

Attach base plate to round or square vertical extrusion using the bolt provided. Be careful not to strip the threads.

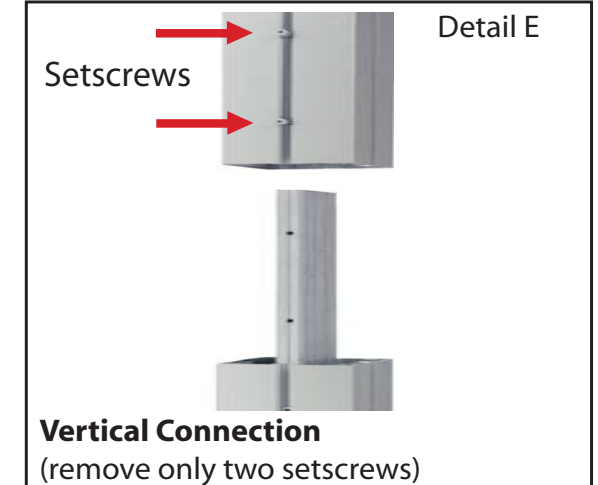

Detail E

Vertical Connection
(remove only two setscrews)

When vertical extrusions are packed in portable cases rather than crates or tubs, they must be broken down into smaller sections which then require assembly.

Remove only (2) setscrews when disassembling. Replace setscrews in extrusion after assembling it. Before packing, replace setscrews in extrusion to avoid losing them.

WHEN DISASSEMBLING ALUMINUM EXTRUSION, TIGHTEN ALL SETSCREWS AND LOCKS TO PREVENT LOSS DURING SHIPPING

866.652.2100

| Item | Qty. | Description |
|------|------|---------------------------------------|
| 1 | 2 | Base Plate w/ 1 Hole |
| 1a | 1 | Base Plate w/ 2 Holes |
| 2 | 1 | 42" h Lower Square Vertical Extrusion |
| 3 | 1 | 42" h Upper Square Vertical Extrusion |
| 4 | 1 | 42" h Lower Square Vertical Extrusion |
| 5 | 1 | 42" h Upper Square Vertical Extrusion |
| 6 | 1 | 42" h Lower Square Vertical Extrusion |
| 7 | 1 | 32" h Upper Square Vertical Extrusion |
| 8 | 1 | 42" h Lower Square Vertical Extrusion |
| 9 | 1 | 42" h Upper Square Vertical Extrusion |
| 10 | 2 | 47" w Horizontal Extrusion |
| 11 | 1 | 38.25" w Horizontal Extrusion |
| 12 | 1 | 40.9826" Curved Extrusion |
| 14 | 1 | 4" Stabilizing Extrusion |

Steps:

- 1) Attach vertical extrusions [2, 4, 6 and 8] to base plates [1 and 1a].
- 2) Attach upper vertical extrusions to lower extrusions using connection bar [b].
- 3) Attach horizontal extrusions [10, 11 and 12] between vertical assemblies as shown.
- 4) Apply graphic to back of assembled backwall.
- 5) Attach light to top of assembled backwall.

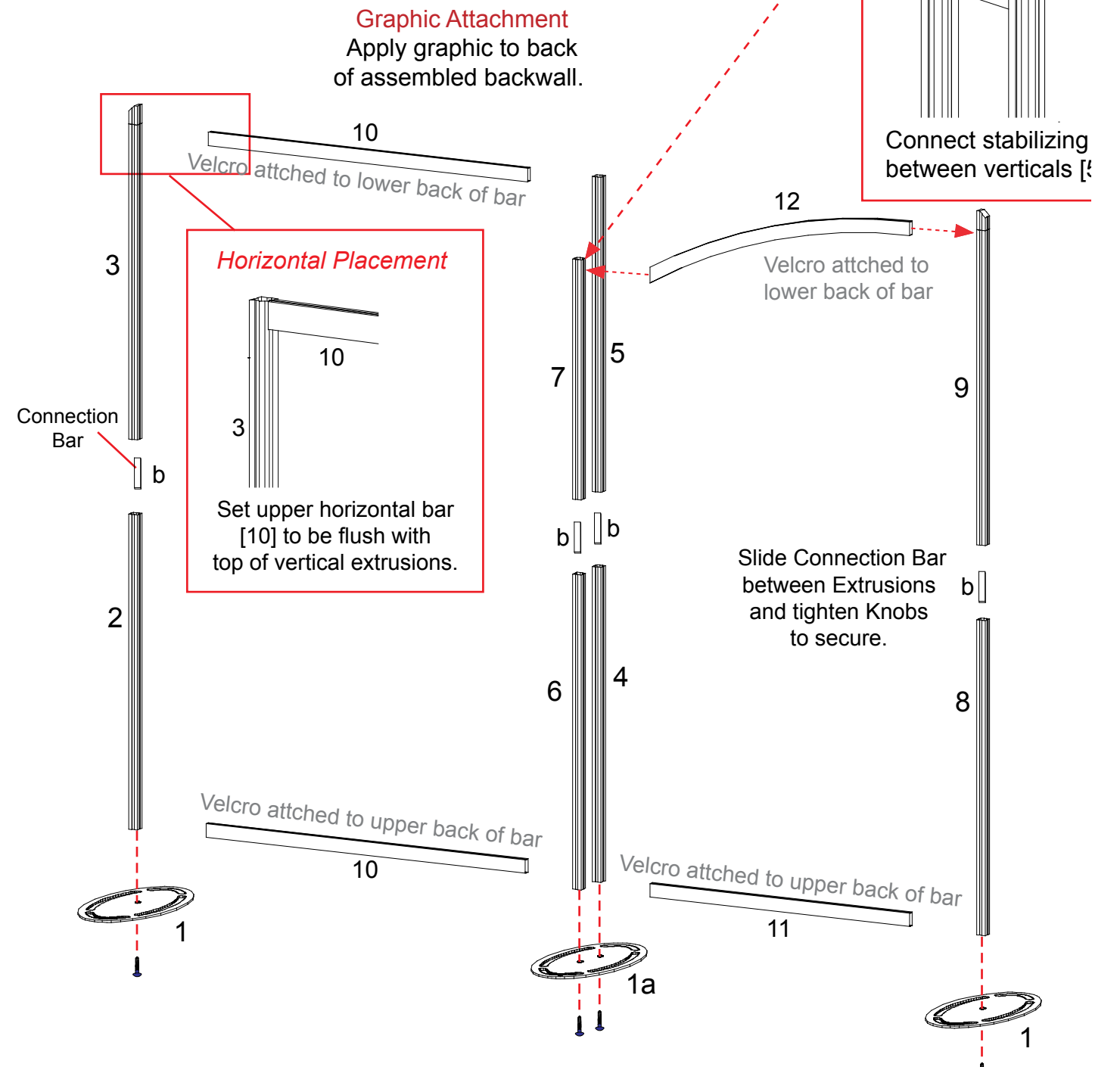
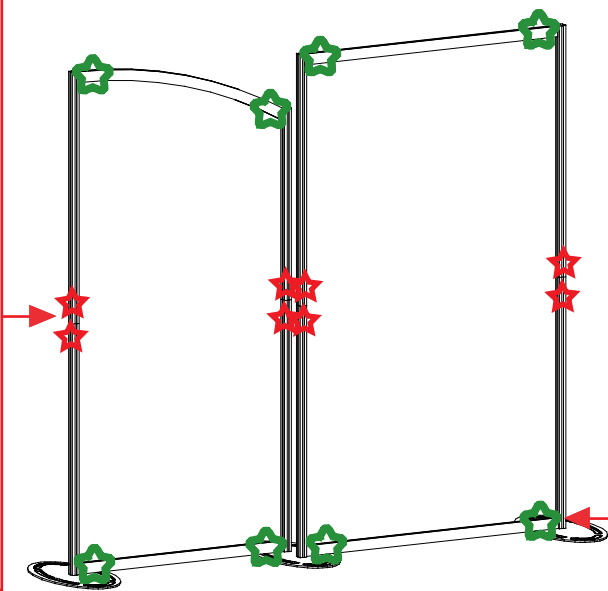
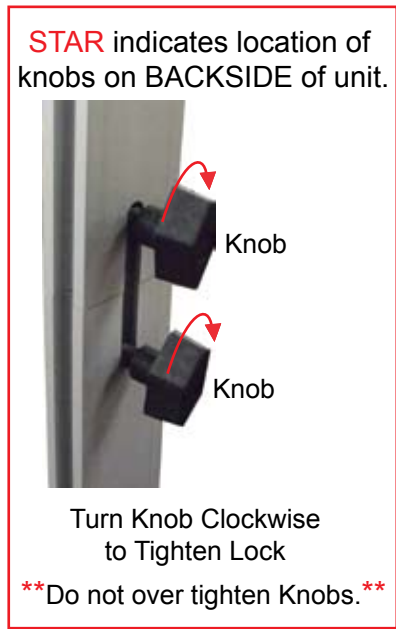
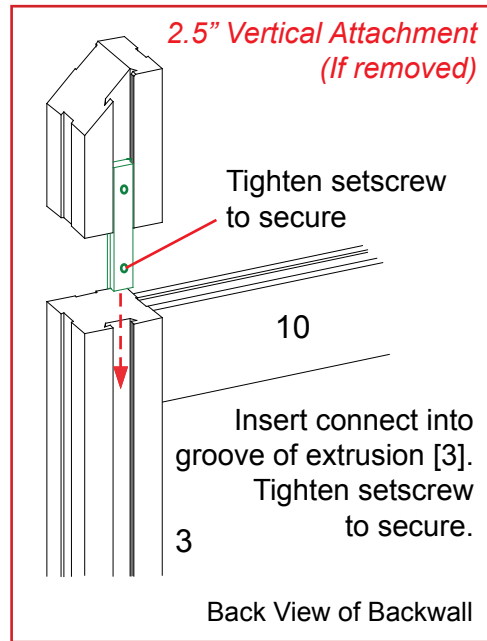
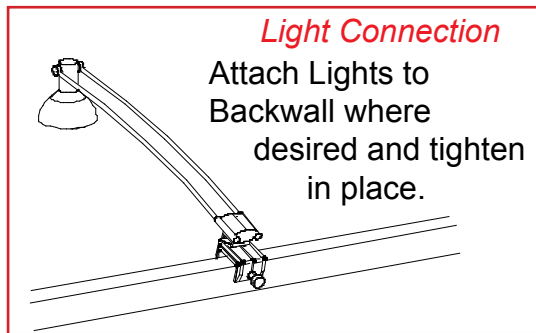

WHEN DISASSEMBLING ALUMINUM EXTRUSION, TIGHTEN ALL SETSCREWS AND LOCKS TO PREVENT LOSS DURING SHIPPING

866.652.2100

| Item | Qty. | Description |
|------|------|---------------------------------------|
| 1 | 2 | Base Plate w/ 1 Hole |
| 1a | 1 | Base Plate w/ 2 Holes |
| 2a | 1 | 42" h Lower Square Vertical Extrusion |
| 3a | 1 | 42" h Upper Square Vertical Extrusion |
| 4a | 1 | 42" h Lower Square Vertical Extrusion |
| 5a | 1 | 42" h Upper Square Vertical Extrusion |
| 6a | 1 | 42" h Lower Square Vertical Extrusion |
| 7a | 1 | 32" h Upper Square Vertical Extrusion |
| 8a | 1 | 42" h Lower Square Vertical Extrusion |
| 9a | 1 | 42" h Upper Square Vertical Extrusion |
| 10 | 2 | 47" w Horizontal Extrusion |
| 11 | 1 | 38.25" w Horizontal Extrusion |
| 12a | 1 | 40.9826" Curved Extrusion |
| 13 | 2 | 24" w Horizontal Extrusion |
| 14 | 1 | 4" Stabilizing Extrusion |

Steps:

- 1) Attach vertical extrusions [2a, 4a, 6a and 8a] to base plates [1 and 1a].
- 2) Attach upper vertical extrusions to lower extrusions using connection bar [b].
- 3) Attach horizontal extrusions [10, 11 and 12a] between vertical assemblies as shown.
- 4) Apply graphic to back of assembled backwall.
- 5) Attach light to top of assembled backwall.

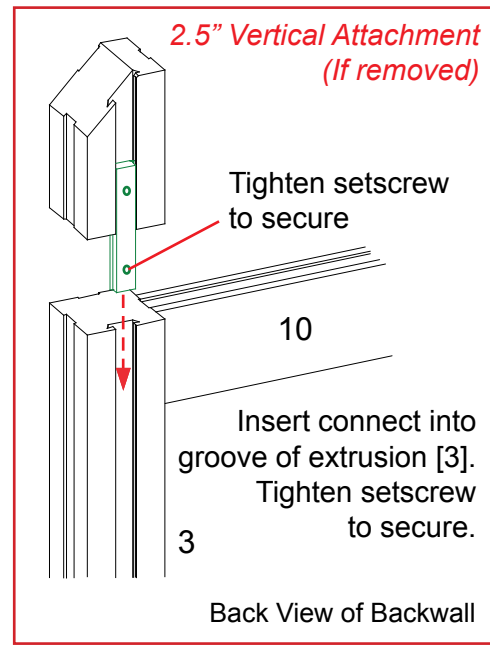
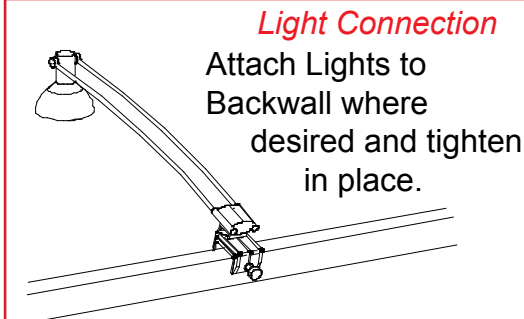
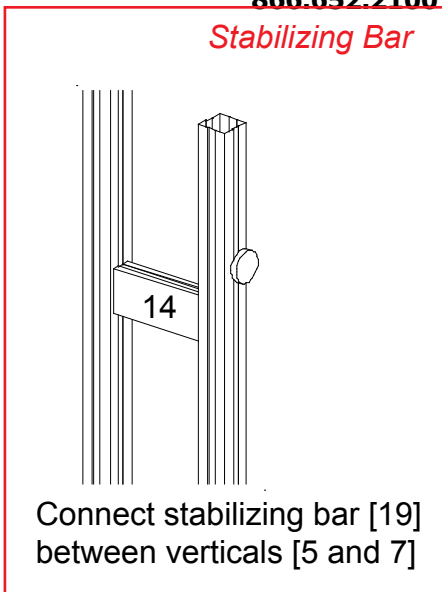

Graphic Attachment
Apply graphic to back of assembled backwall.

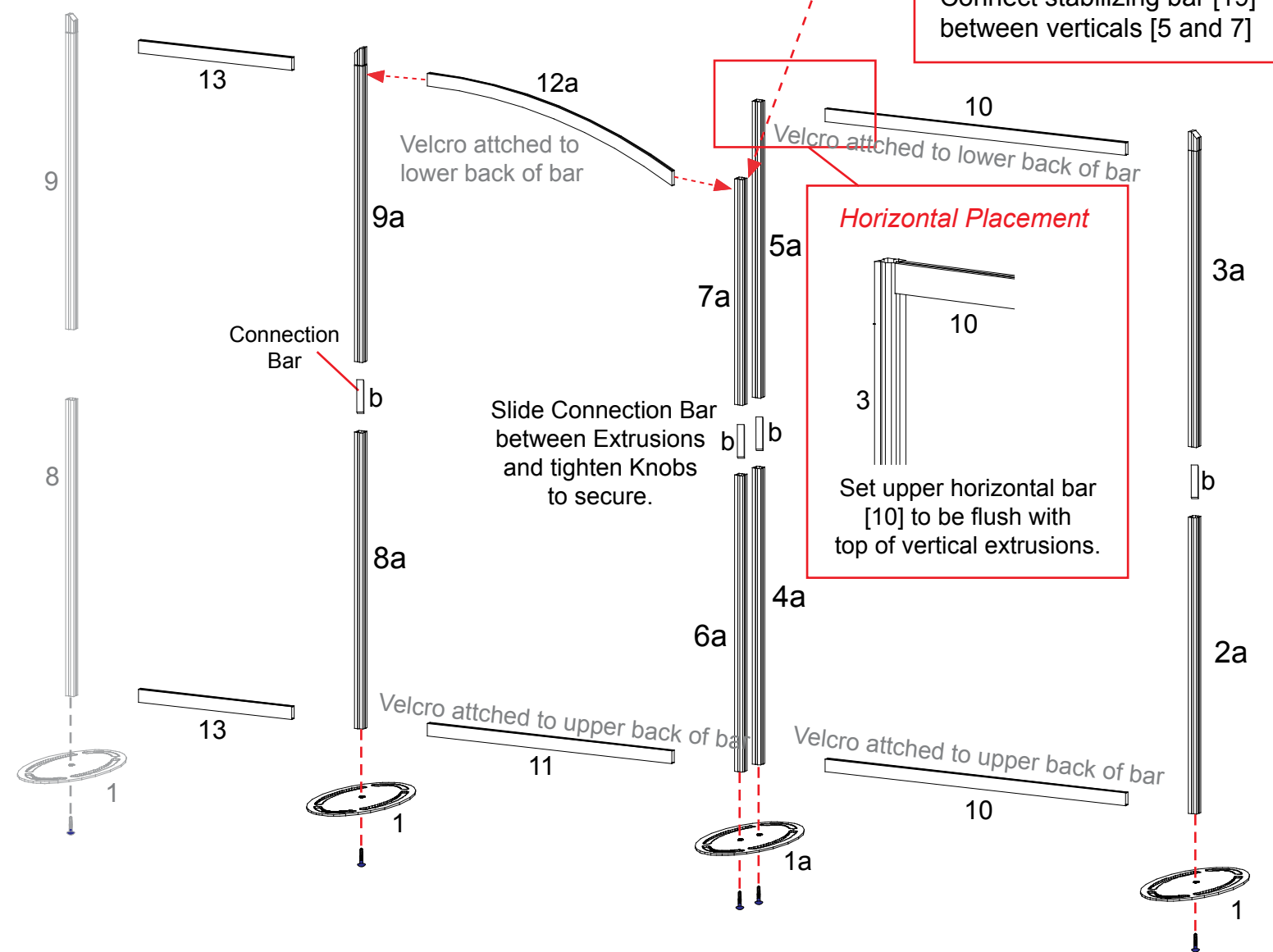

STAR indicates location of knobs on BACKSIDE of unit.

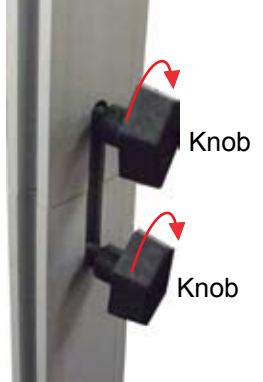

Do not over tighten Knobs.

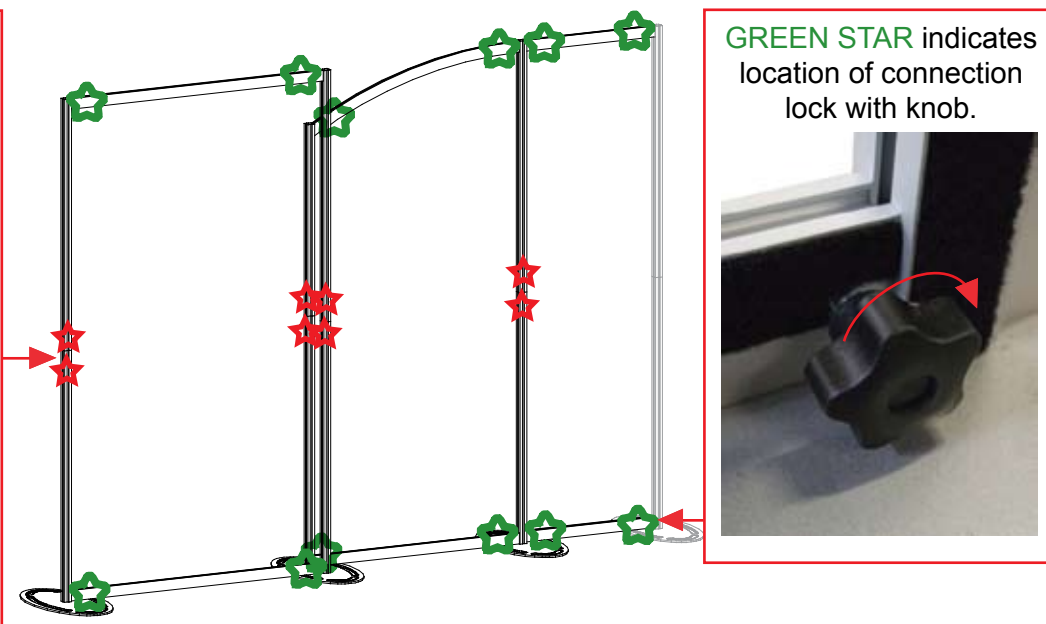

WHEN DISASSEMBLING ALUMINUM EXTRUSION, TIGHTEN ALL SETSCREWS AND LOCKS TO PREVENT LOSS DURING SHIPPING

866.652.2100

Light Connection
 Attach Lights to Backwall where desired and tighten in place.

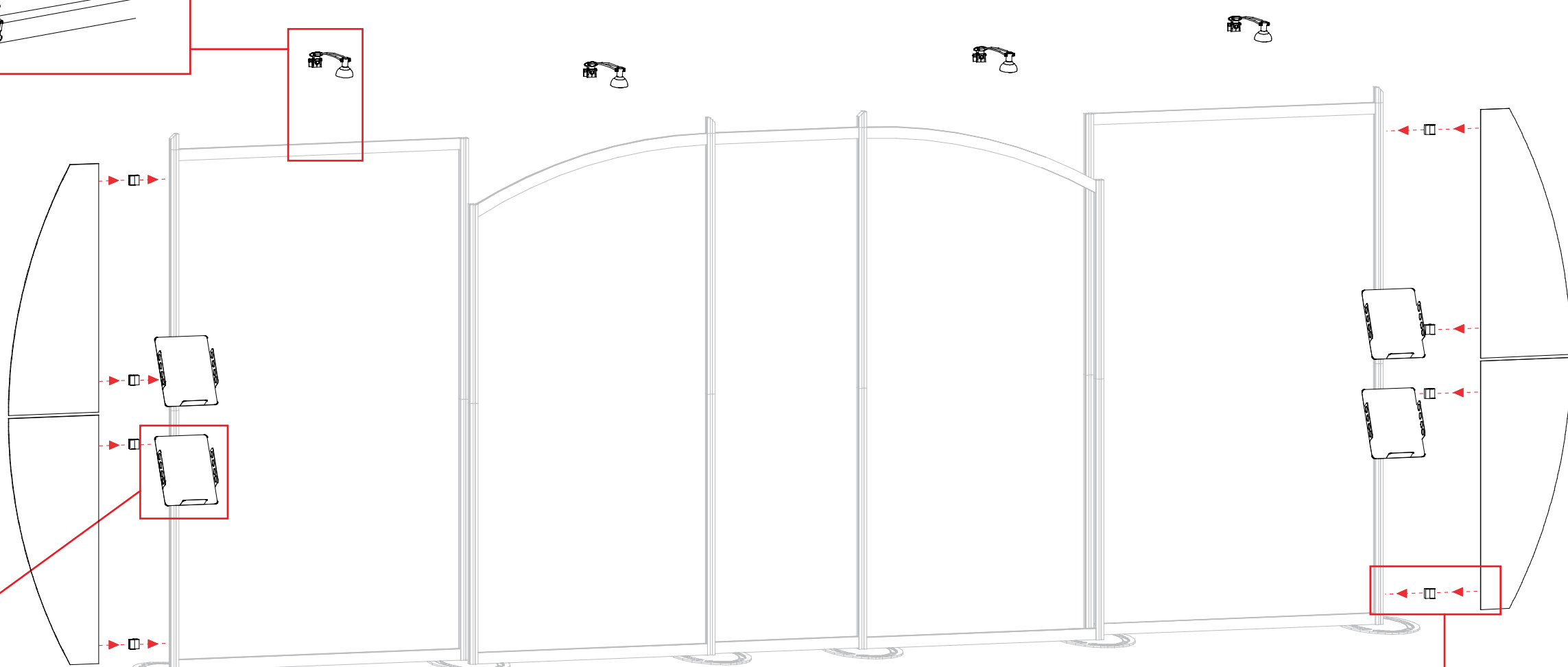

Literature Rack Attachment

Tighten Lock to Secure

Attach connector piece to rack as shown. Then connect assembled literature rack to vertical extrusion.

Example of A10 Clamp Attachment (If removed)

Slide connector on back of A10 clamp into groove of extrusion.

When desired location is found, tighten set screw to secure.

Tighten knob to secure wing in place.

WHEN DISASSEMBLING ALUMINUM EXTRUSION, TIGHTEN ALL SETSCREWS AND LOCKS TO PREVENT LOSS DURING SHIPPING

Top View of each Level

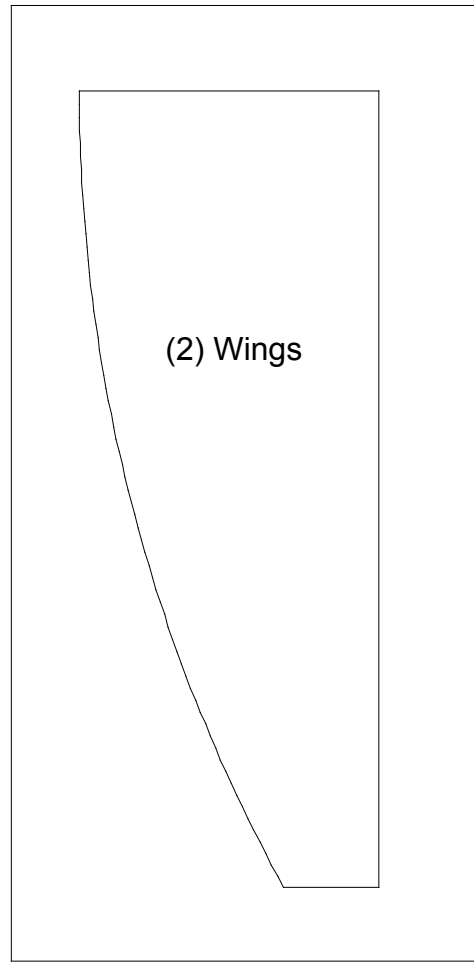

Level 1 [Bottom]

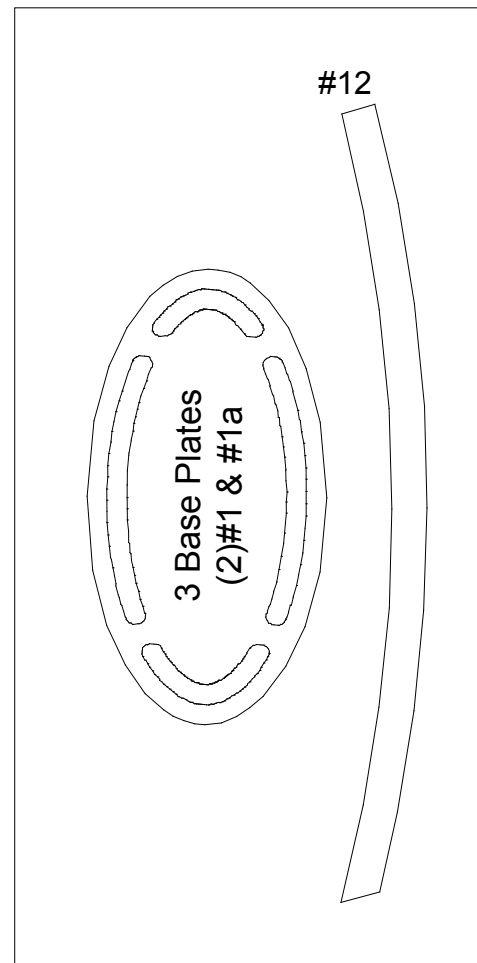

Level 2

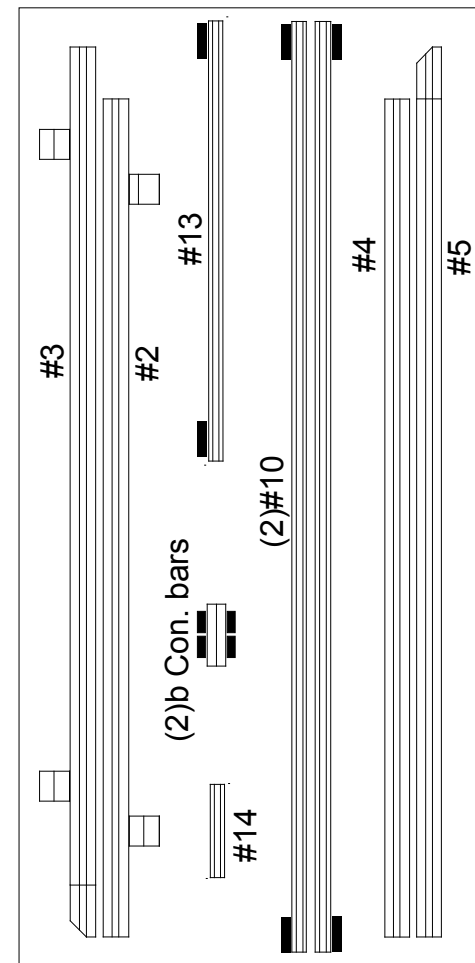

Level 3

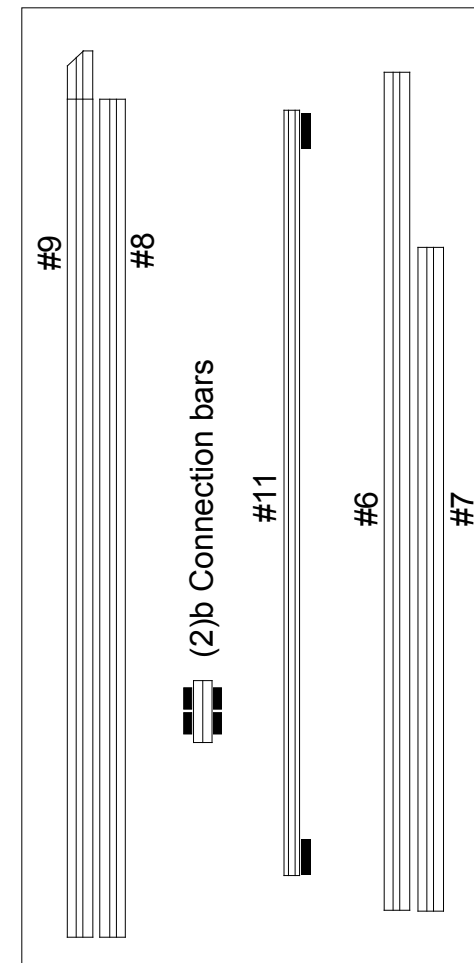

Level 4

Halogen Lights

Literature Pockets

Setup Hardware

WHEN DISASSEMBLING ALUMINUM EXTRUSION, TIGHTEN ALL SETSCREWS AND LOCKS TO PREVENT LOSS DURING SHIPPING

Top View of each Level

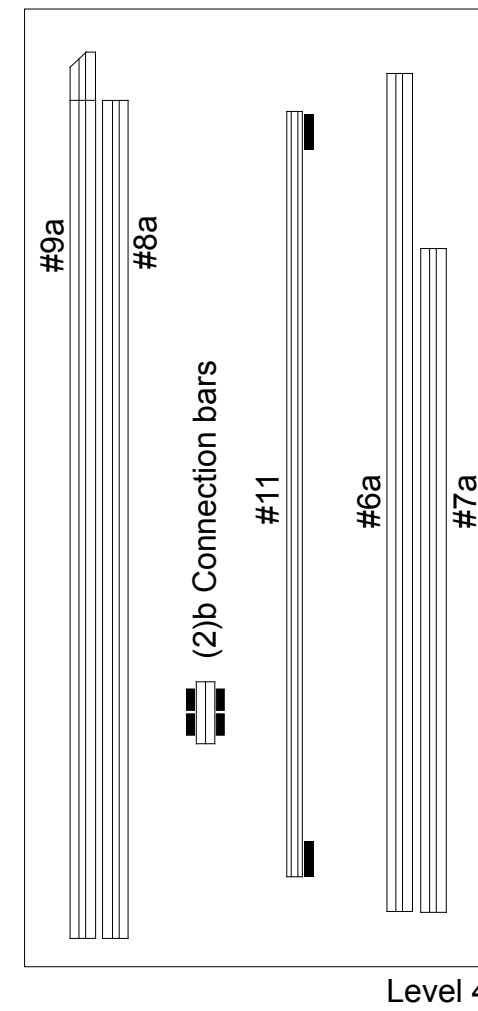
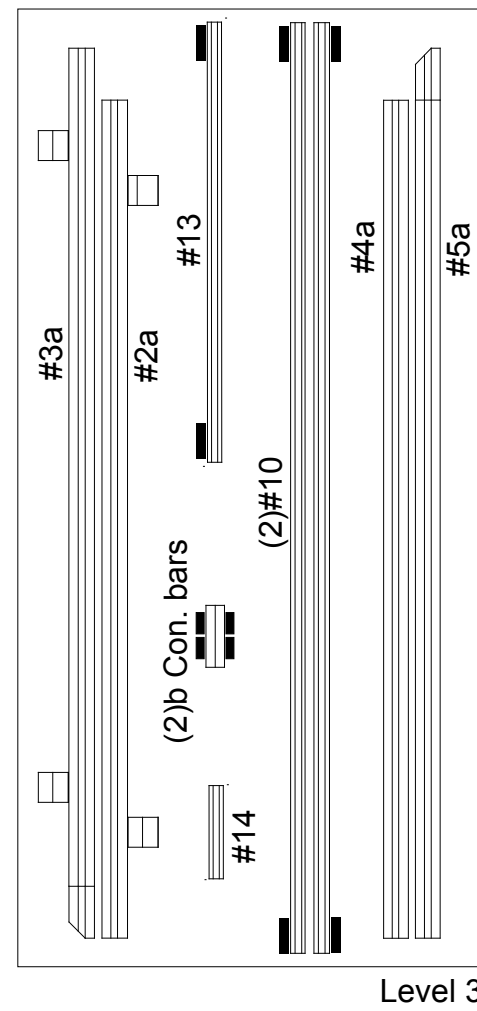
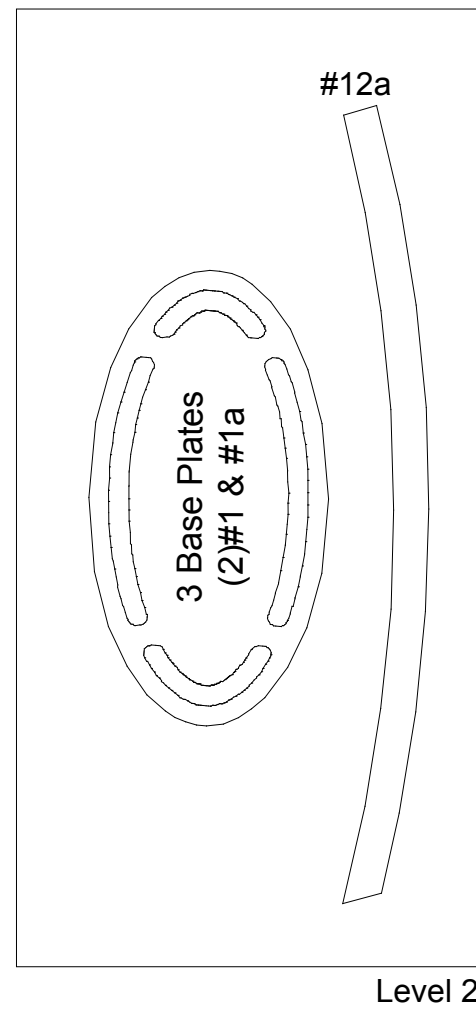
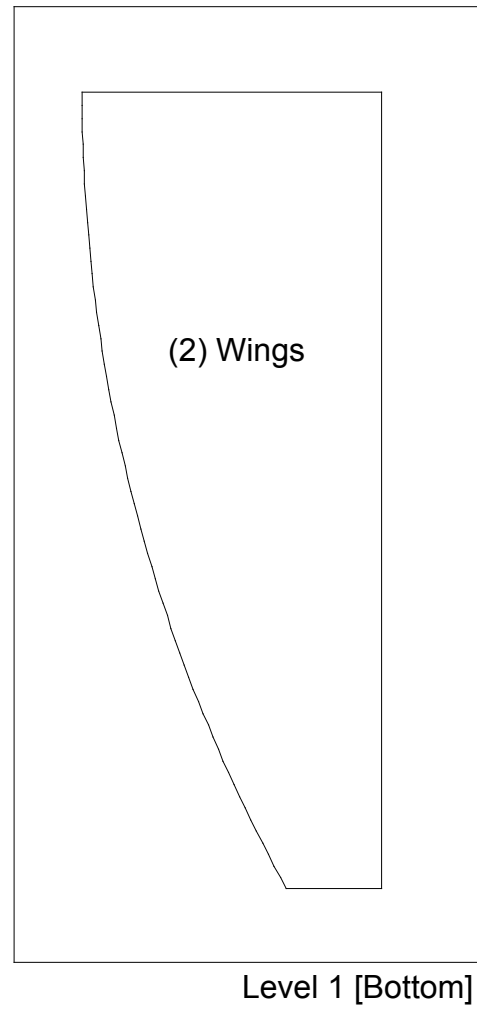

Halogen Lights

Literature Pockets

Setup Hardware

WHEN DISASSEMBLING ALUMINUM EXTRUSION, TIGHTEN ALL SETSCREWS AND LOCKS TO PREVENT LOSS DURING SHIPPING