

## General Setup Instructions

### Using Your Setup Instructions

The Setup Instructions are created specifically for your configuration. They are laid out sequentially in levels, including exploded views, and a logical series of detailed steps to assemble the main structure and components. We encourage you to study the instructions **before** attempting to assemble your exhibit.

Each page reminds you to tighten the setscrews after disassembling your exhibit to prevent loss of the locks and setscrews (see below in RED). This is VERY IMPORTANT.

### Cleaning and Packing Your Display

- 1) Use care when cleaning aluminum extrusion or Eco Glass inserts. Use only non-abrasive cleaners.
- 2) When cleaning laminate inserts, countertops, or panels use mild cleansers and a soft material such as cotton.
- 3) Keep all display components away from extreme heat and long exposure to sunlight to avoid warping and fading.
- 4) Retain all packing material. It will make re-packing much easier and will reduce the likelihood of shipping damage. Each Layer will be labeled with the packing order.

## General Setup Instructions for Panel System

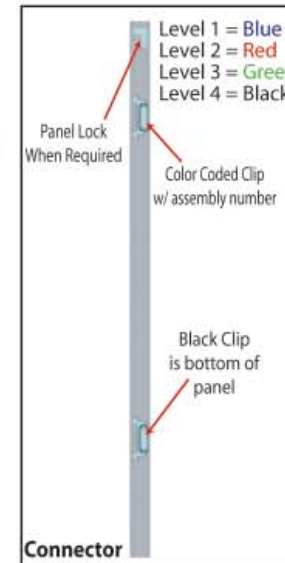

Each component has 2 clips, the lower clip is ALWAYS black. The top clip is color coded to distinguish the level. The color coded clip also contains the numbered label.

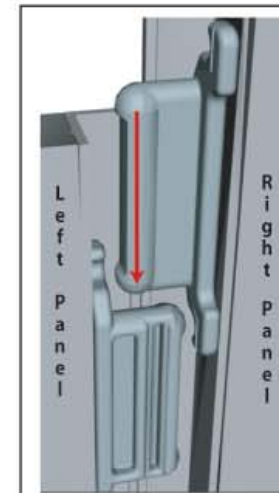

Cut Away View Of Slide Clips

Components connect together by aligning them and sliding downward connecting clips together.

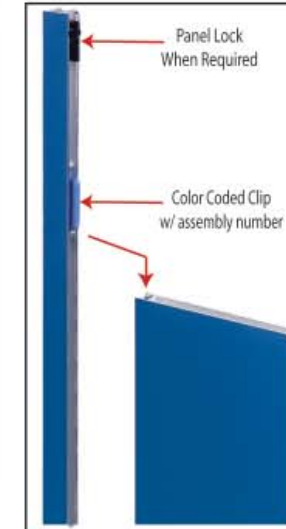

Example of Connection

Configurations are assembled from left to right, usually starting with #1 and following the numbered sequence.

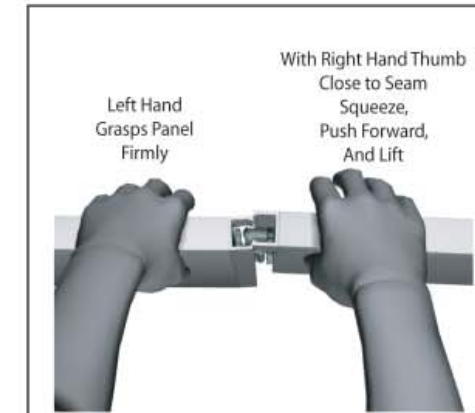

Top View of Panels with Locks

The first level of components contains panel locks that are located at the top of the panel for extra stability and a seamless connection. When disassembling panels, twist top connection slightly and lift right panel upward.

## General Setup Instructions for Extrusion System



The Tool

Most exhibits can be assembled with the supplied Hex Key Tool. Occasionally, other tools may be needed.



Typical Connection

Most horizontal extrusion connections have a patented expandable lock. This lock inserts into the groove of an opposing extrusion. Tightening the lock with the Hex Key Tool expands the lock and creates a strong positive connection.



Typical Connection (cont'd)

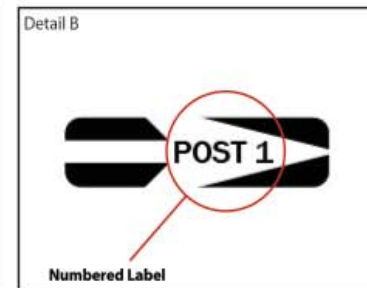

Numbered Label

Each extrusion contains a numbered label which corresponds with setup instructions. The label is located within a groove of the extrusion (when possible). With extrusion components the labels contain Black numbers unless otherwise specified.



Horizontal Inline Connection (remove only one setscrew)

Remove only (1) setscrew when disassembling. Replace setscrew in extrusion after assembling it. Before packing, replace setscrew in extrusion to avoid losing it.

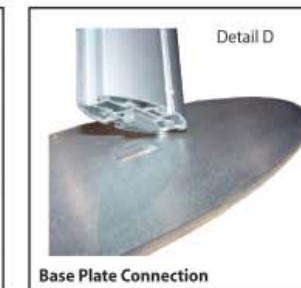

Base Plate Connection

Attach base plate to vertical extrusion using the lock provided. Place base plate on ground and set vertical post/lock in base plate slot. Tighten lock with Mult-tool.

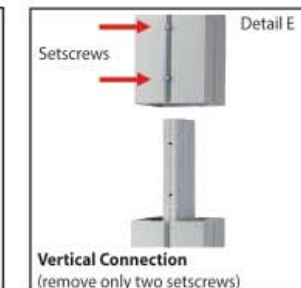

Vertical Connection (remove only two setscrews)

When vertical extrusions are packed in portable cases rather than crates or tubs, they must be broken down into smaller sections which then require assembly.

Remove only (2) setscrews when disassembling. Replace setscrews in extrusion after assembling it. Before packing, replace setscrews in extrusion to avoid losing them.

Item Number	Qty.	Description
1	4	Base Plate
2	1	94" h Vertical Extrusion
3	1	80" h Vertical Extrusion
4	1	80" h Vertical Extrusion
5	1	94" h Vertical Extrusion
6	2	47" w Horizontal Extrusion
7	2	47" w Horizontal Extrusion
8/8a	1/1	47" h Vertical Extrusion
9	2	53" h Vertical Extrusion

Steps:

- 1) Attach base plates with bottom of verticals, see Detail D on general page.
- 2) Connect horizontal extrusions between vertical extrusions.  
*Velcro side must face forward*  
*See location of the panel clips below*
- 3) Attach wing and header panels to clips as shown.

**Clip Attachment**

Slide connector on back of A10 clamp into groove of extrusion.

When desired location is found, tighten set screw to secure.

Tighten knob to secure shelf in place.

**Example of Knob Attachment**

Knob

**\*\*Do not over tighten Knobs.\*\***  
**Insert lock into groove and tighten knob to secure lock.**

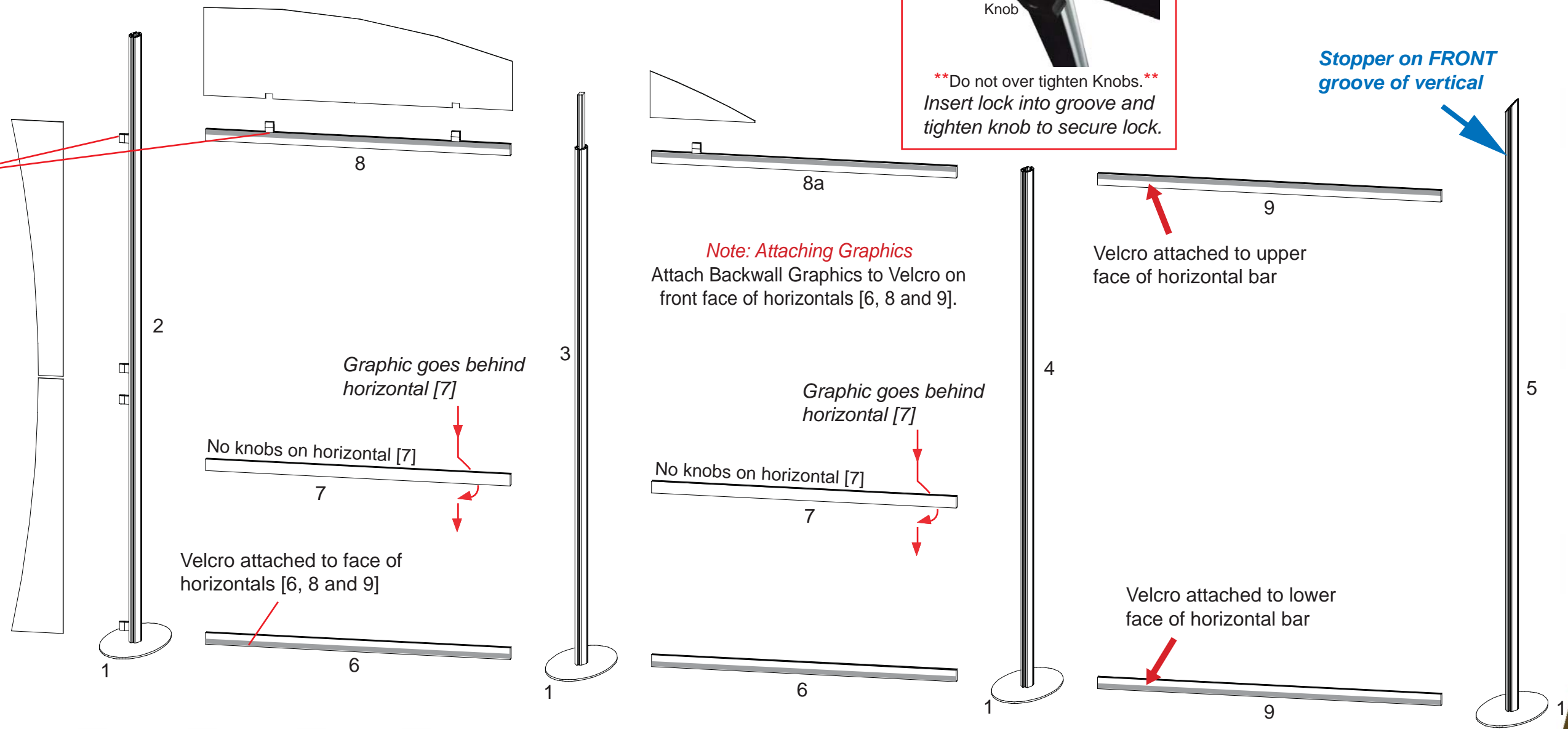

Item Number	Qty.	Description
1	4	Base Plate
2	1	94" h Vertical Extrusion
3	1	80" h Vertical Extrusion
4	1	80" h Vertical Extrusion
5	1	94" h Vertical Extrusion
6	2	47" w Horizontal Extrusion
7	2	47" w Horizontal Extrusion
8	2	47" w Horizontal Extrusion
9	2	53" w Horizontal Extrusion
9a	2	30" w Horizontal Extrusion

Steps:

- 1) Attach base plates with bottom of verticals, see Detail D on general page.
- 2) Connect horizontal extrusions between vertical extrusions.  
*Velcro side must face forward*  
*See location of the panel clips below*
- 3) Attach wing and header panels to clips as shown.

*Example of Knob Attachment*

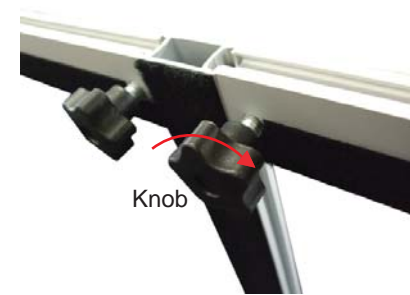

**\*\*Do not over tighten Knobs.\*\***  
 Insert lock into groove and tighten knob to secure lock.

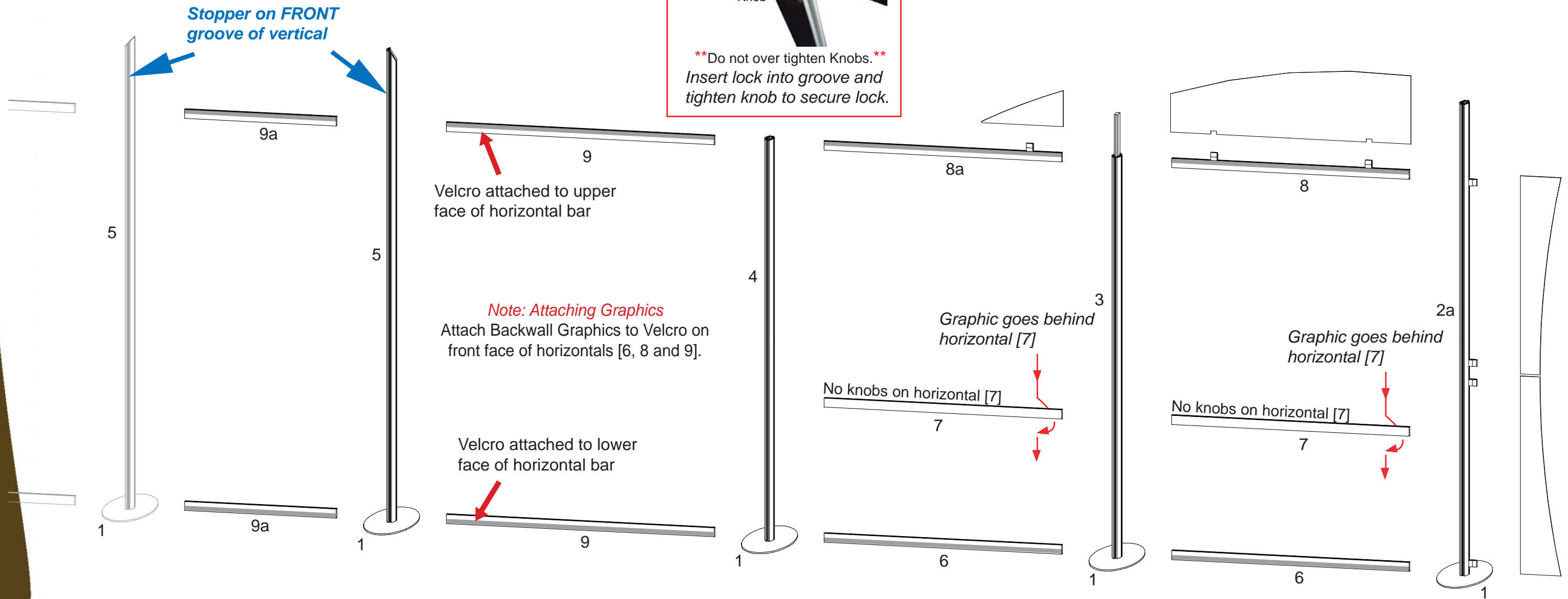

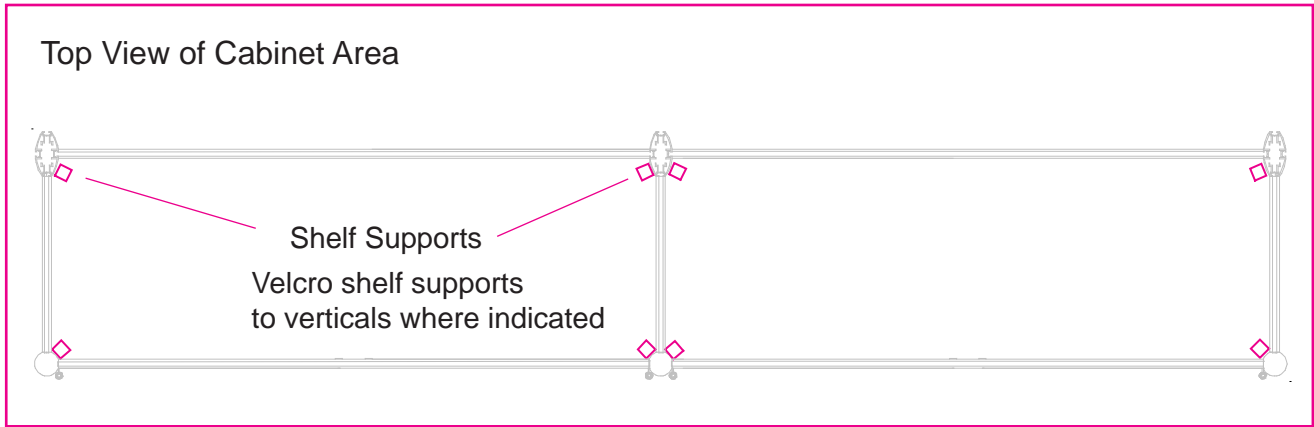

Item Number	Qty.	Description
10	1	29" h Vertical Extrusion w/ Door Hinges
11	1	29" h Vertical Extrusion w/ Door Hinges
12	1	29" h Vertical Extrusion w/ Door Hinges
13	6	14" w Horizontal Extrusion
14	4	46.989" w Horizontal Extrusion
15	2	25.417" h Vertical extrusions w/ Door Stops

Steps:

- 1) Lock horizontals [13] between backwall verticals and round verticals [10, 11 and 12]. See below for hinge orientation.
- 2) Lock bottom horizontals [14] between verticals [10, 11 and 12].
- 3) Attach verticals [15] to top of horizontals [14], leave loose.
- 4) Attach doors where indicated then tighten verticals [15] in place.
- 5) Lock upper horizontals [14] atop doors and verticals [15].
- 6) Velcro shelf supports where indicated.
- 7) Set 2-piece counter top on assembled cabinet.

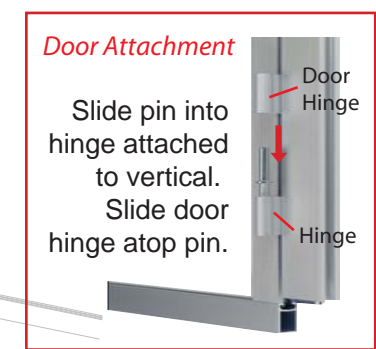
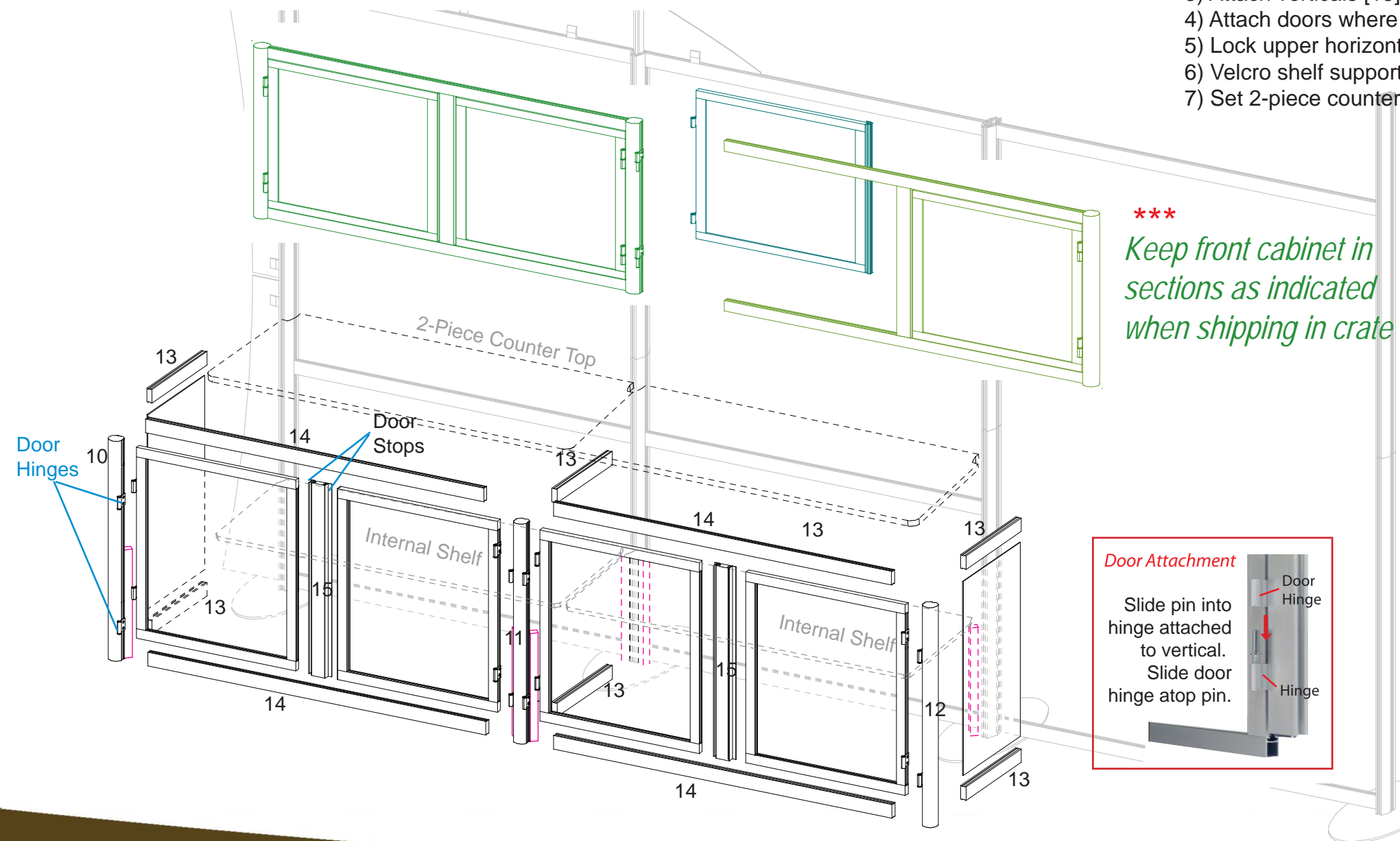

Steps:

- 1) Lock horizontals [13] between backwall verticals and round verticals [10, 11 and 12]  
See below for hinge orientation.
- 2) Lock bottom horizontals [14] between verticals [10, 11 and 12].
- 3) Attach verticals [15] to top of horizontals [14], leave loose.
- 4) Attach doors where indicated then tighten verticals [15] in place.
- 5) Lock upper horizontals [14] atop doors and verticals [15].
- 6) Velcro shelf supports where indicated.
- 7) Set 2-piece counter top on assembled cabinet.

Item Number	Qty.	Description
10	1	29"h Vertical Extrusion w/ Door Hinges
11	1	29"h Vertical Extrusion w/ Door Hinges
12	1	29"h Vertical Extrusion w/ Door Hinges
13	6	14"w Horizontal Extrusion
14	4	46.989"w Horizontal Extrusion
15	2	25.417"h Vertical extrusions w/ Door Stops

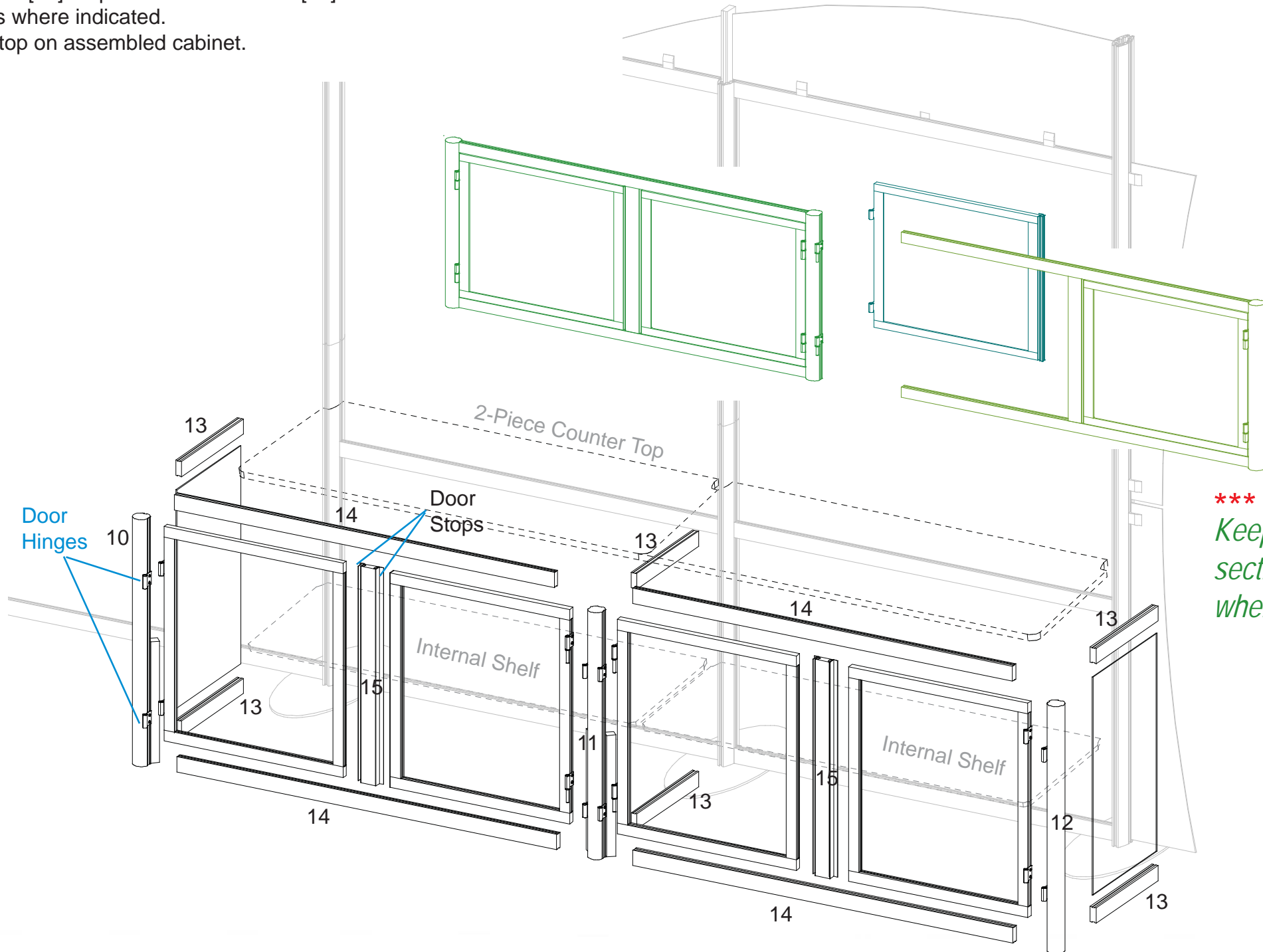

Lock into pill slot underside of canopy frame  
\*\* Apply pillow case cover on frame before  
attaching to backwall \*\*

- Steps:
- 1) Attach canopy frame to top of backwall verticals as shown.
  - 2) Attach shelf with support to backwall verticals where indicated.

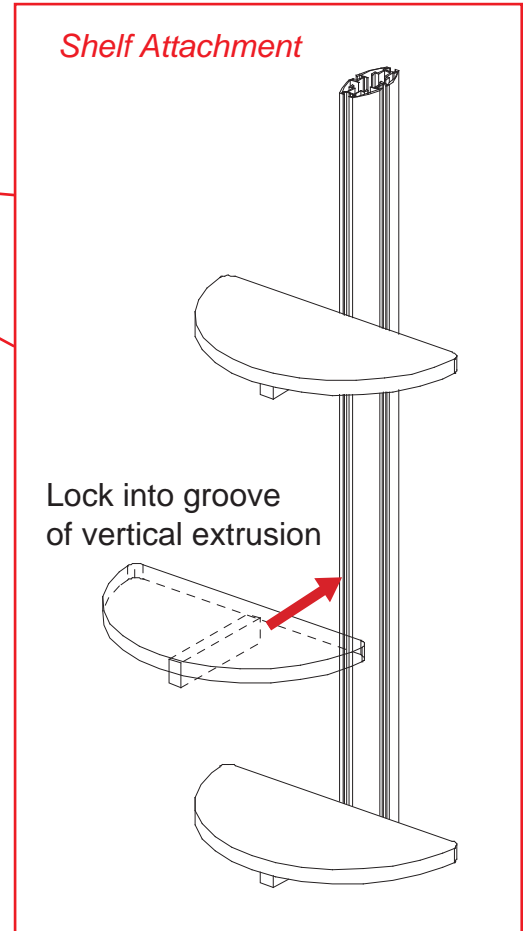
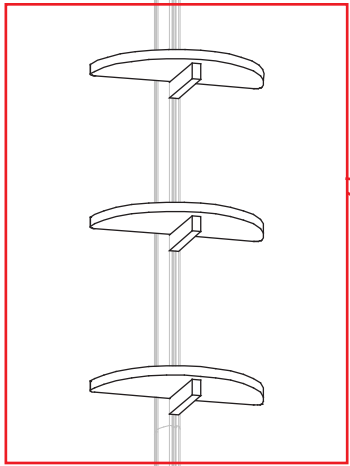
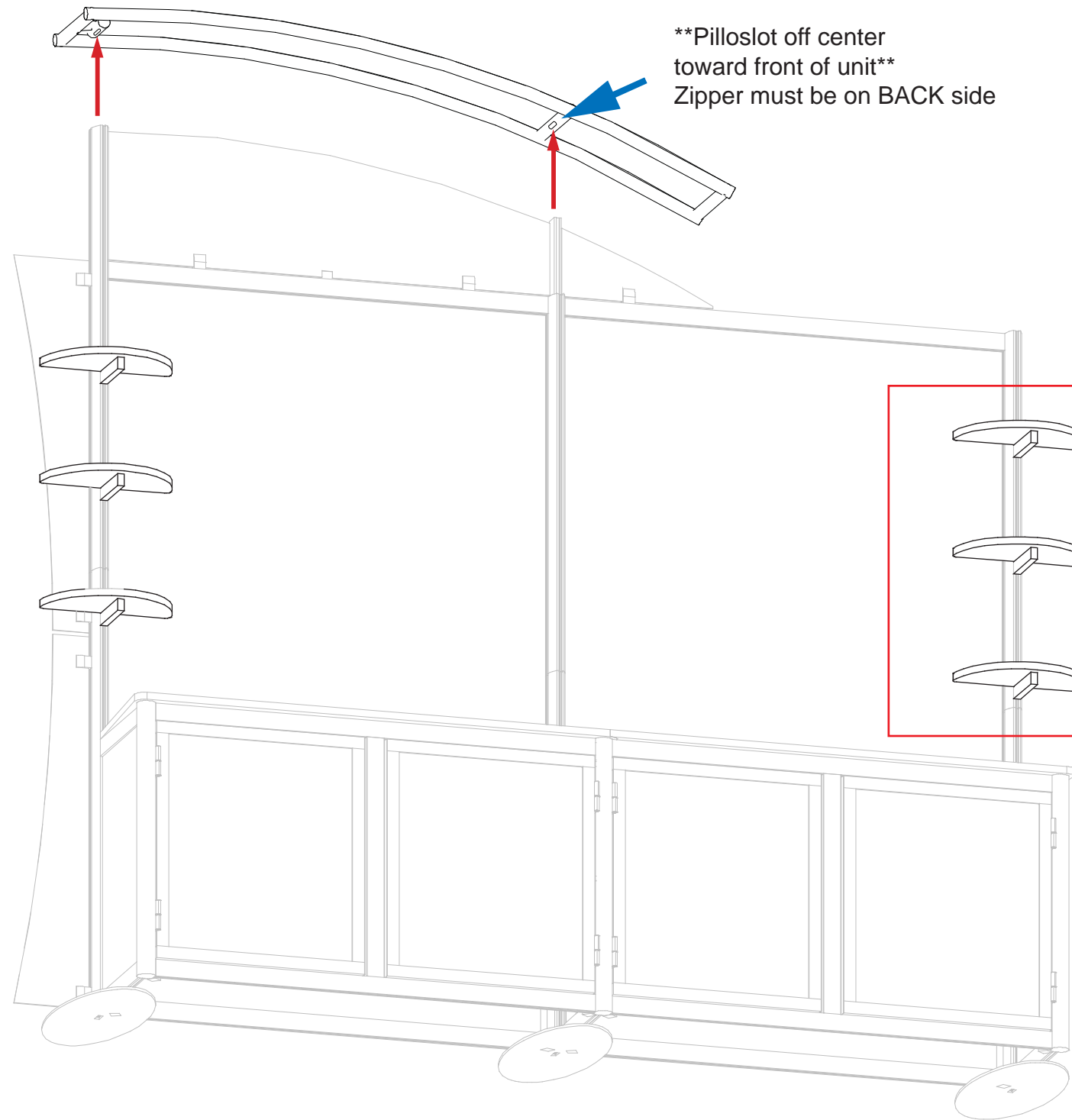

Steps:

- 1) Attach canopy frame to top of backwall verticals as shown.
- 2) Attach shelf with support to backwall verticals where indicated.

Lock into pill slot underside of canopy frame  
\*\* Apply pillow case cover on frame before attaching to backwall \*\*

\*\*Pilloslot off center toward front of unit\*\*  
Zipper must be on BACK side

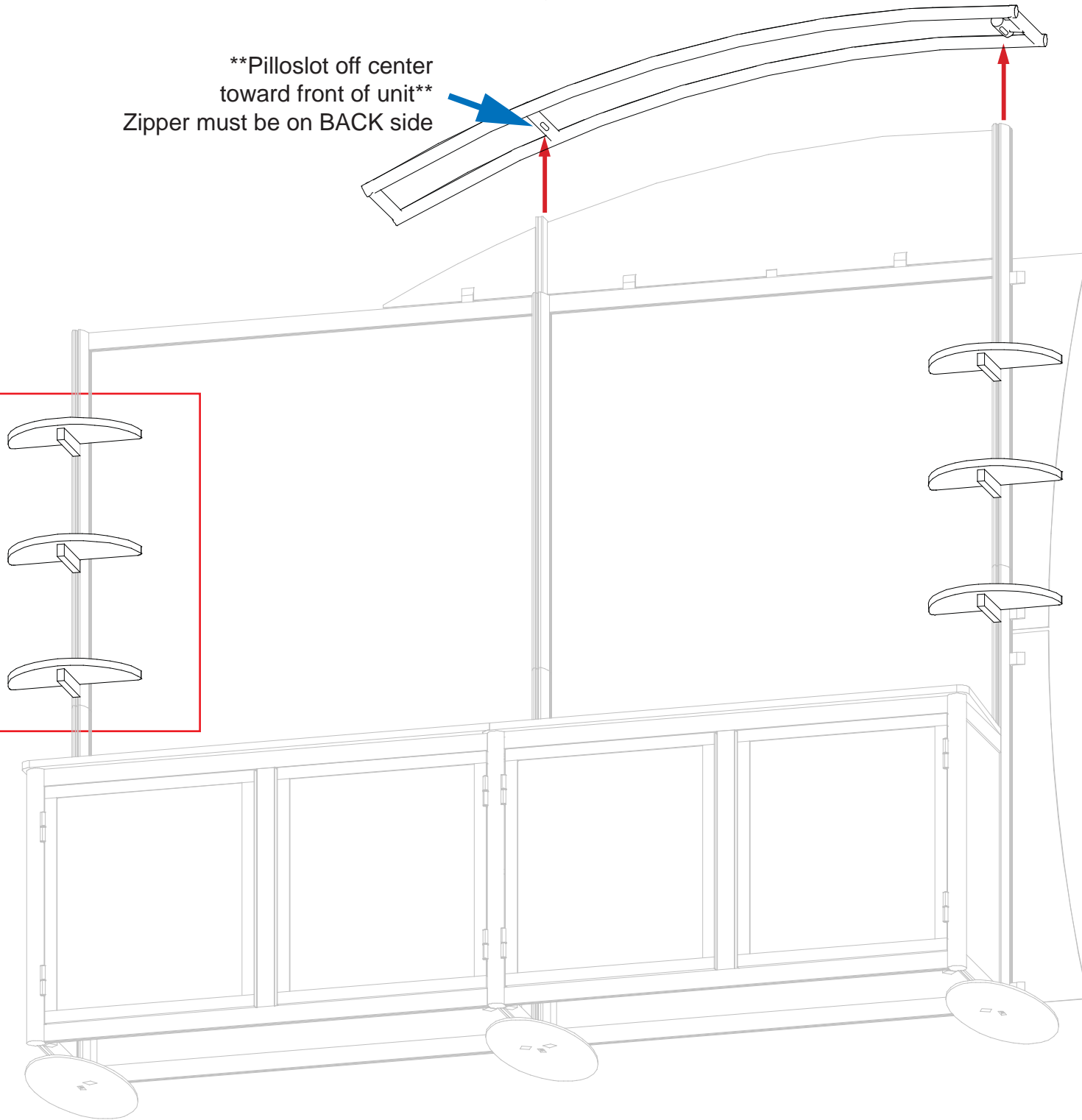
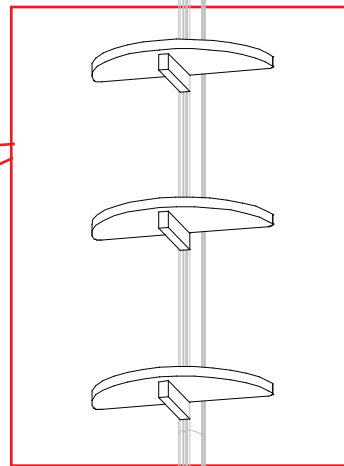
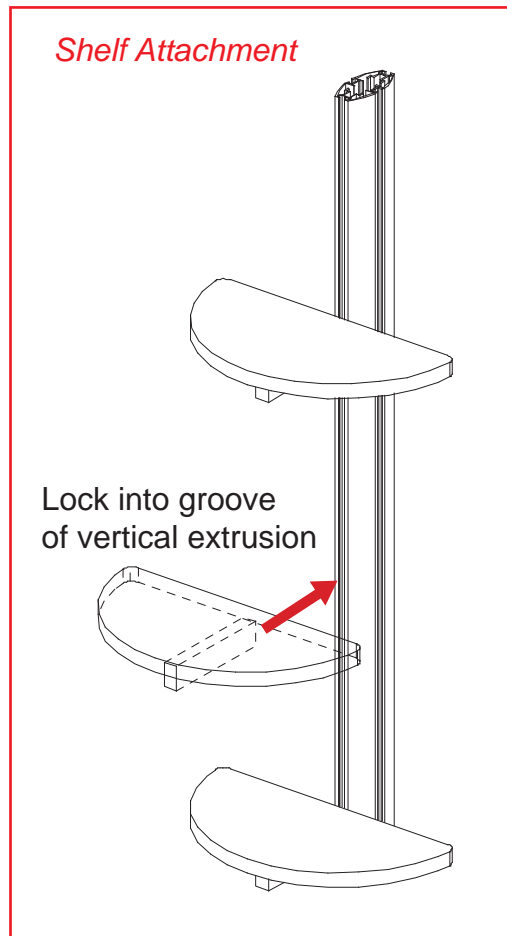

**Using Your Setup Instructions**

The Aero Overhead Sign Setup Instructions are created specifically for your configuration. They include an exploded view of the frame which is sequentially numbered. We encourage you to study the instructions before attempting to assemble your exhibit.

Connections are kept very simple: no tools. Everything assembles with push-button connectors and pre-connected horizontal sections.

**Cleaning and Packing Your Display**

- 1) Use care when cleaning aluminum extrusion or acrylic inserts. Use only non-abrasive cleaners.
- 2) Retain all packing material. It will make re-packing much easier and will reduce the likelihood of shipping damage.

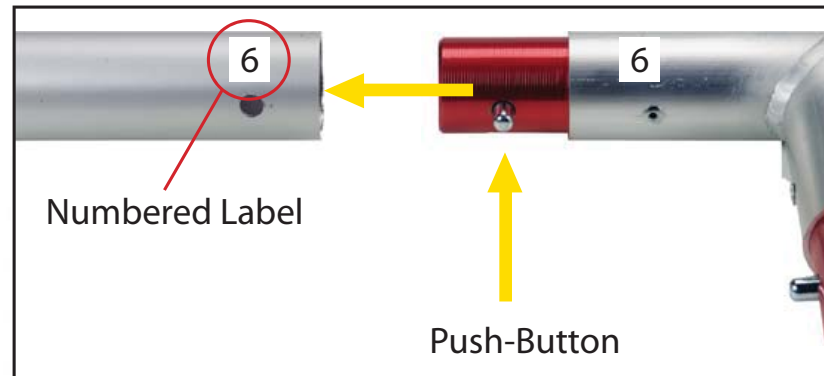

Connections are made by holding the button down and sliding the red tube into opposing tube until the connection is made. To disassemble push button and pull or twist extrusions apart.

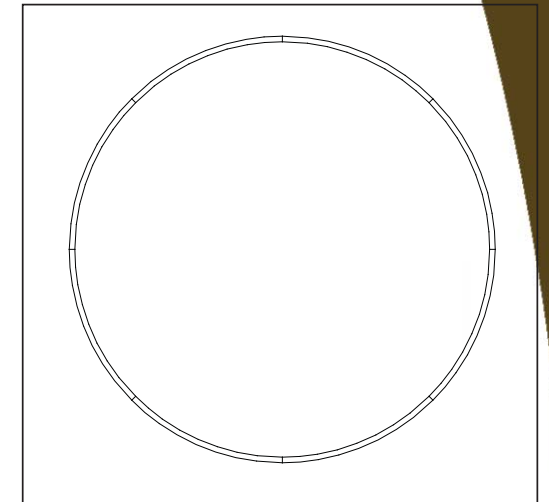
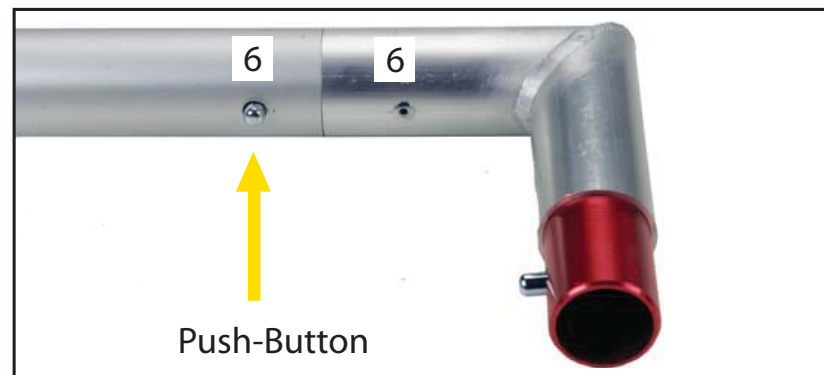

**NOTE:** Bolts attached to *backside* of frame  
Graphic must attach to opposite side of bolts

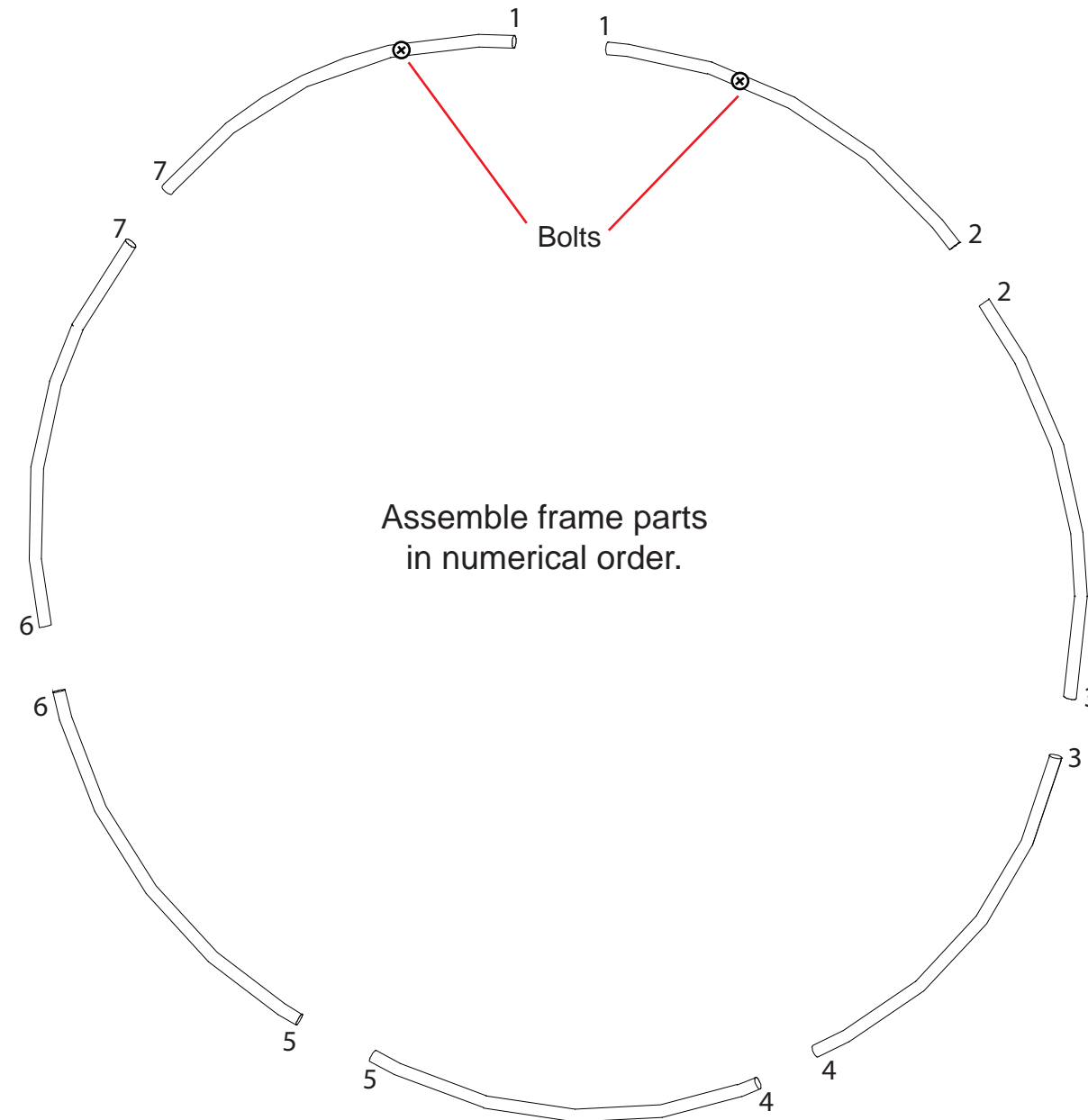

Steps:

1) Attached assembled circle frame with graphic to backwall verticals as shown.

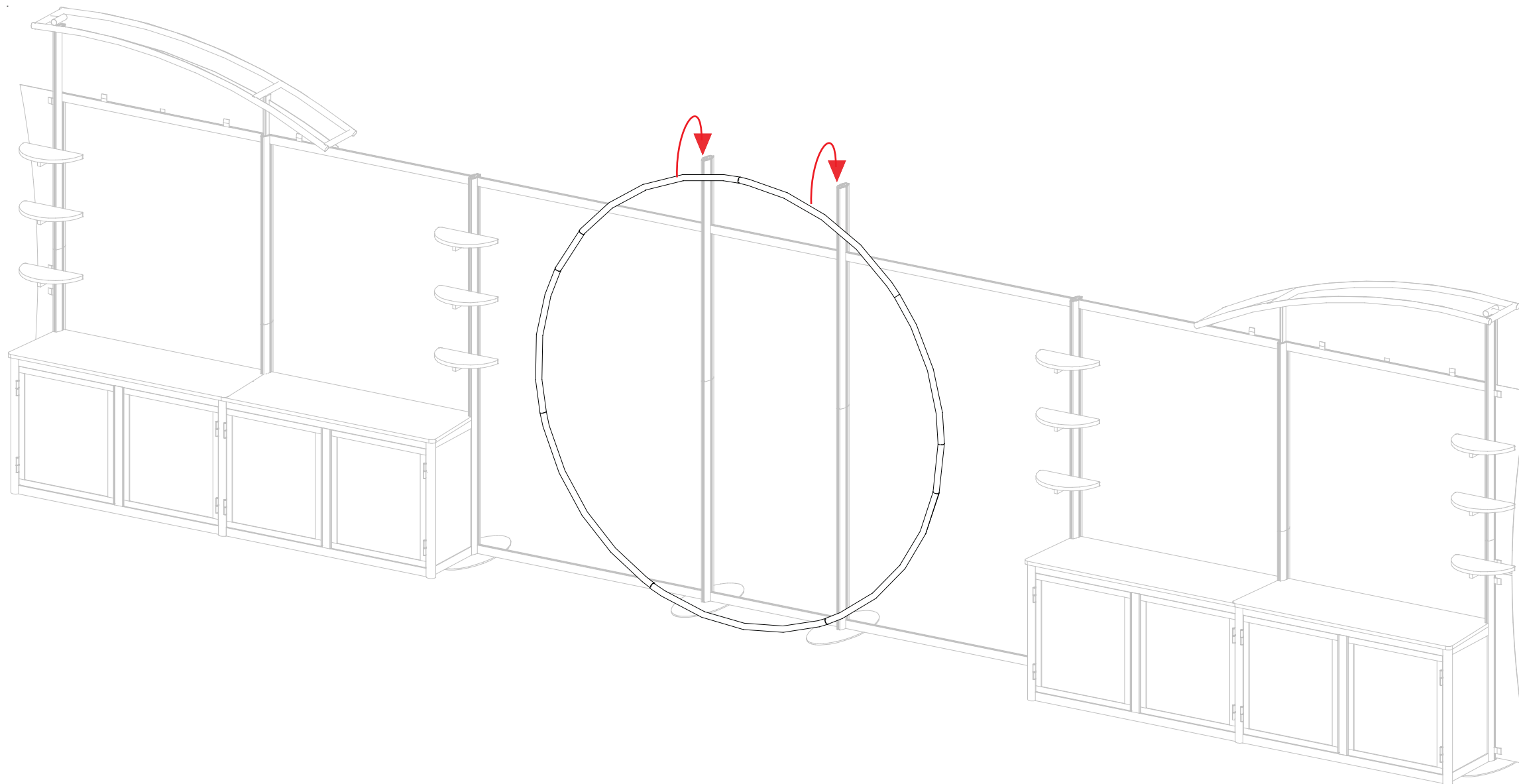

*Circle Frame Attachment*

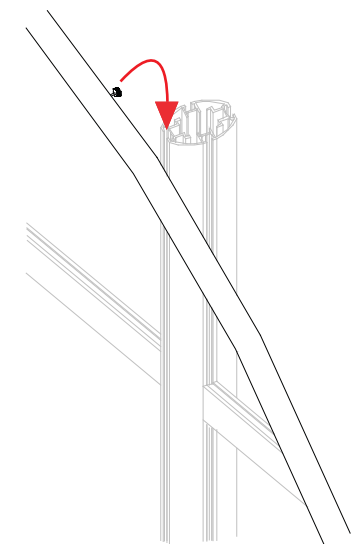

Slide in bolts on back of assembled circle into groove of vertical extrusions. Rest bolts on stoppers.

Item Number	Qty.	Description
16	4	30" h Round Vertical Extrusion
17	4	40" h Round Vertical Extrusion
18	12	18" w Horizontal Extrusion
19	8	38" w Horizontal Extrusion

Steps:

- 1) Connect lower horizontal extrusions between vertical extrusions as shown.
- 2) Slide infills between vertical extrusions as indicated.
- 3) Connect upper horizontal extrusions between vertical extrusions as shown.
- 4) Place counter tops atop assembled base.

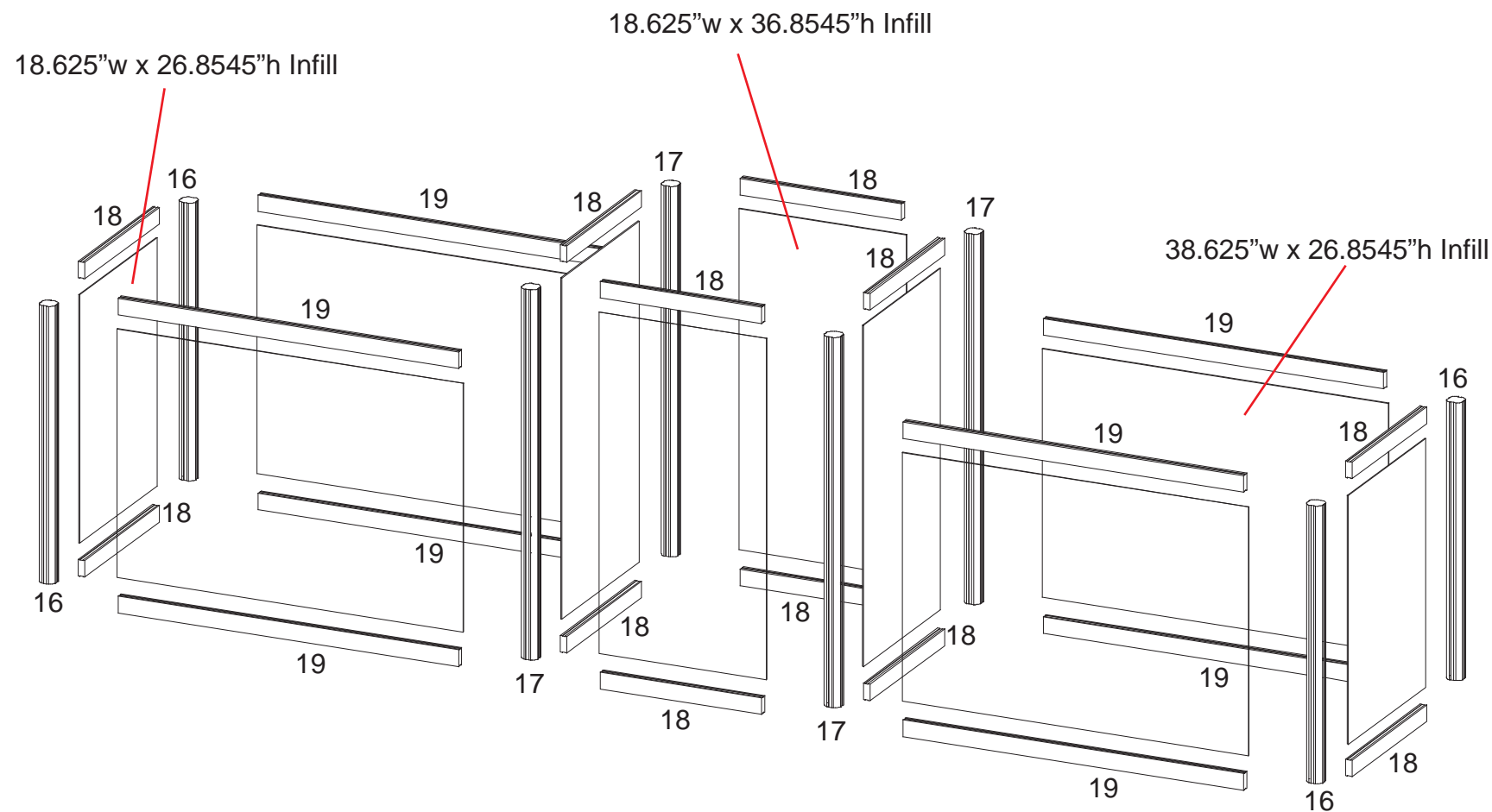

Place counter tops on assembled base

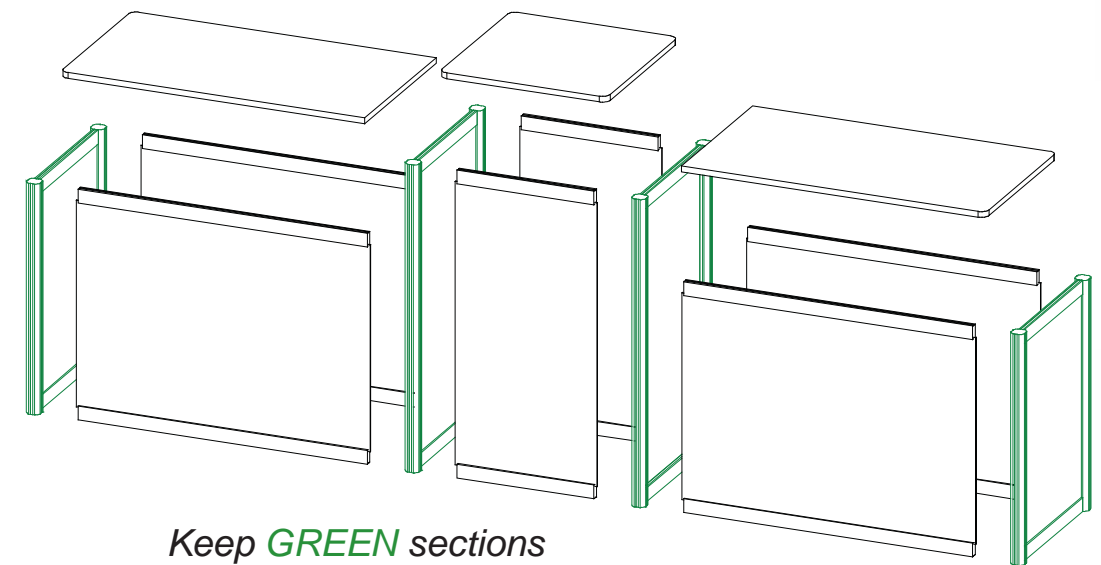

Keep **GREEN** sections assembled when shipping in custom crate

Item Number	Qty.	Description
17	4	40" h Round Vertical Extrusion
18	8	18" w Horizontal Extrusion

Steps:

- 1) Connect lower horizontal extrusions between vertical extrusions as shown.
- 2) Slide infills between vertical extrusions as indicated.
- 3) Connect upper horizontal extrusions between vertical extrusions as shown.
- 4) Place counter tops atop assembled base.

