

Plan View

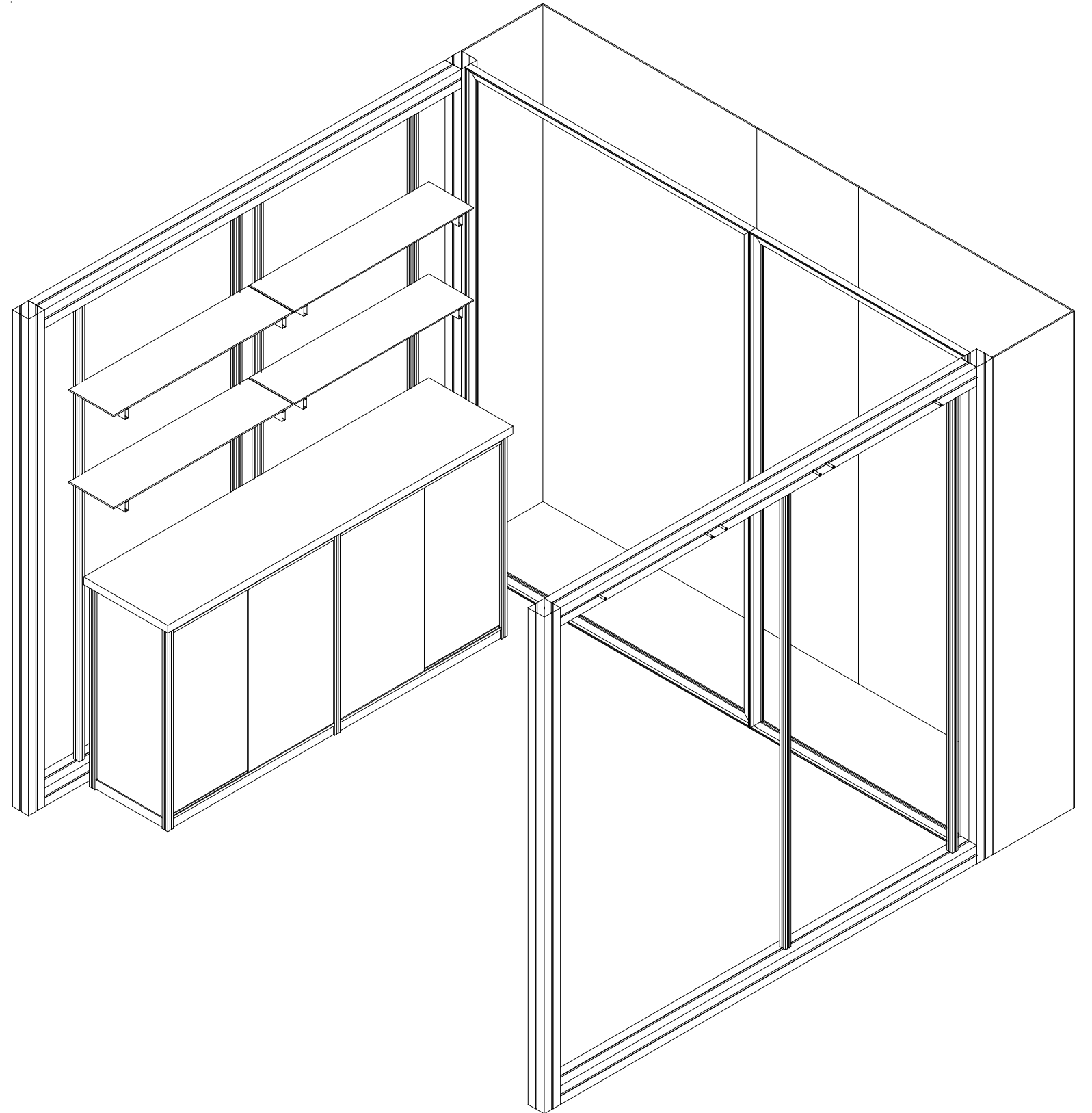

WHEN DISASSEMBLING ALUMINUM EXTRUSION, TIGHTEN ALL SETSCREWS AND LOCKS TO PREVENT LOSS DURING SHIPPING

# visionary™ DESIGNS

## Using Your Setup Instructions

The Visionary Designs Setup Instructions are created specifically for your configuration. They are laid out sequentially, including an exploded view of the entire display, and then a logical series of detailed steps to assemble the main structure and components. We encourage you to study the instructions **before** attempting to assemble your exhibit.

Each page reminds you to tighten the setscrews after disassembling your exhibit to prevent loss of the locks and setscrews (see below in RED). This is **VERY IMPORTANT**.

## Cleaning and Packing Your Display

- 1) Use care when cleaning aluminum extrusion or acrylic inserts. Use only non-abrasive cleaners.
- 2) When cleaning laminate inserts or countertops, use mild cleansers and a soft material such as cotton.
- 3) Keep all display components away from extreme heat and long exposure to sunlight to avoid warping and fading.
- 4) Retain all packing material. It will make re-packing much easier and will reduce the likelihood of shipping damage.



**The Tool**

Most Visionary Designs exhibits can be assembled with the supplied Hex Key Tool. Occasionally, a flat head screwdriver may be required.



**Typical Connection**



**Typical Connection (cont'd)**

Most horizontal extrusion connections have a patented expandable lock. This lock inserts into the groove of an opposing extrusion. Tightening the lock with the Hex Key Tool expands the lock and creates a strong positive connection.

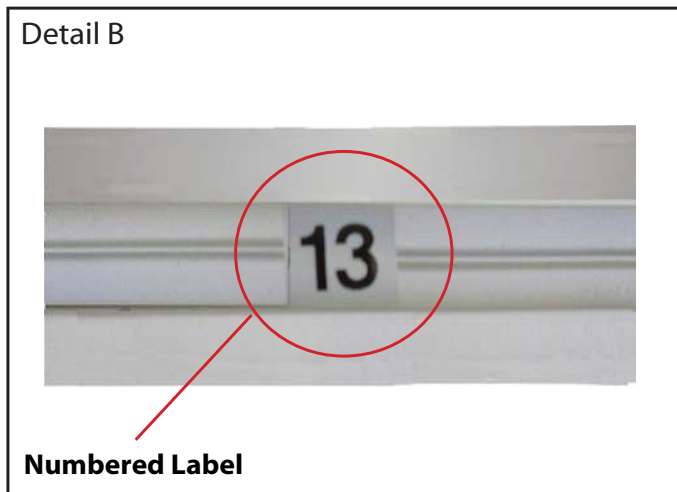

**Detail B**

**Numbered Label**

Each extrusion contains a numbered label which corresponds with setup instructions. The label is located within a groove of the extrusion (when possible). With Visionary Designs the labels contain Black numbers unless otherwise specified.



**Detail C**

**Horizontal Inline Connection** (remove only one setscrew)

Remove only (1) setscrew when disassembling. Replace setscrew in extrusion after assembling it. Before packing, replace setscrew in extrusion to avoid losing it.

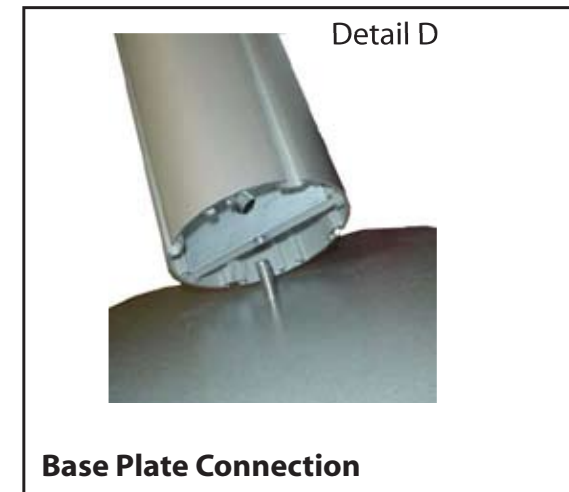

**Detail D**

**Base Plate Connection**

Attach base plate to round or square vertical extrusion using the bolt provided. Be careful not to strip the threads.

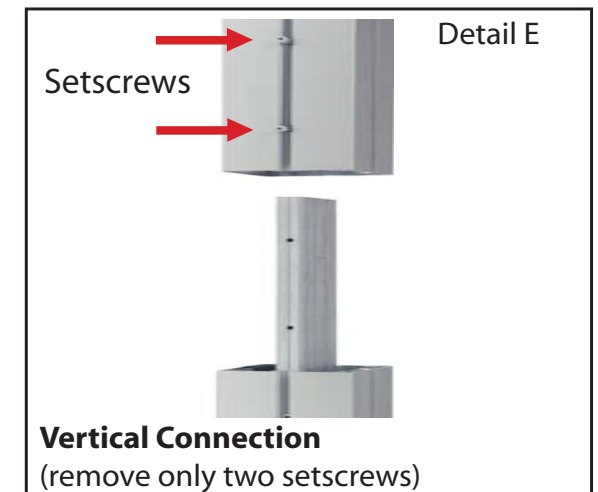

**Detail E**

**Vertical Connection**  
(remove only two setscrews)

When vertical extrusions are packed in portable cases rather than crates or tubs, they must be broken down into smaller sections which then require assembly.

Remove only (2) setscrews when disassembling. Replace setscrews in extrusion after assembling it. Before packing, replace setscrews in extrusion to avoid losing them.

**WHEN DISASSEMBLING ALUMINUM EXTRUSION, TIGHTEN ALL SETSCREWS AND LOCKS TO PREVENT LOSS DURING SHIPPING**

Item	Qty.	Description
1	1	63.583"w Horizontal Extrusion
2	1	63.583"w Horizontal Extrusion
4	1	96"w Vertical Extrusion
8	1	96"w Vertical Extrusion
9	1	48"w Horizontal Extrusion
10	1	96"w Vertical Extrusion
11	1	48"w Horizontal Extrusion
12	1	96"w Vertical Extrusion

Steps:

- 1) Assemble each individual frame pieces together, see detail below for corner lock connection.
- 2) Lock small graphic frame to large center graphic frame.

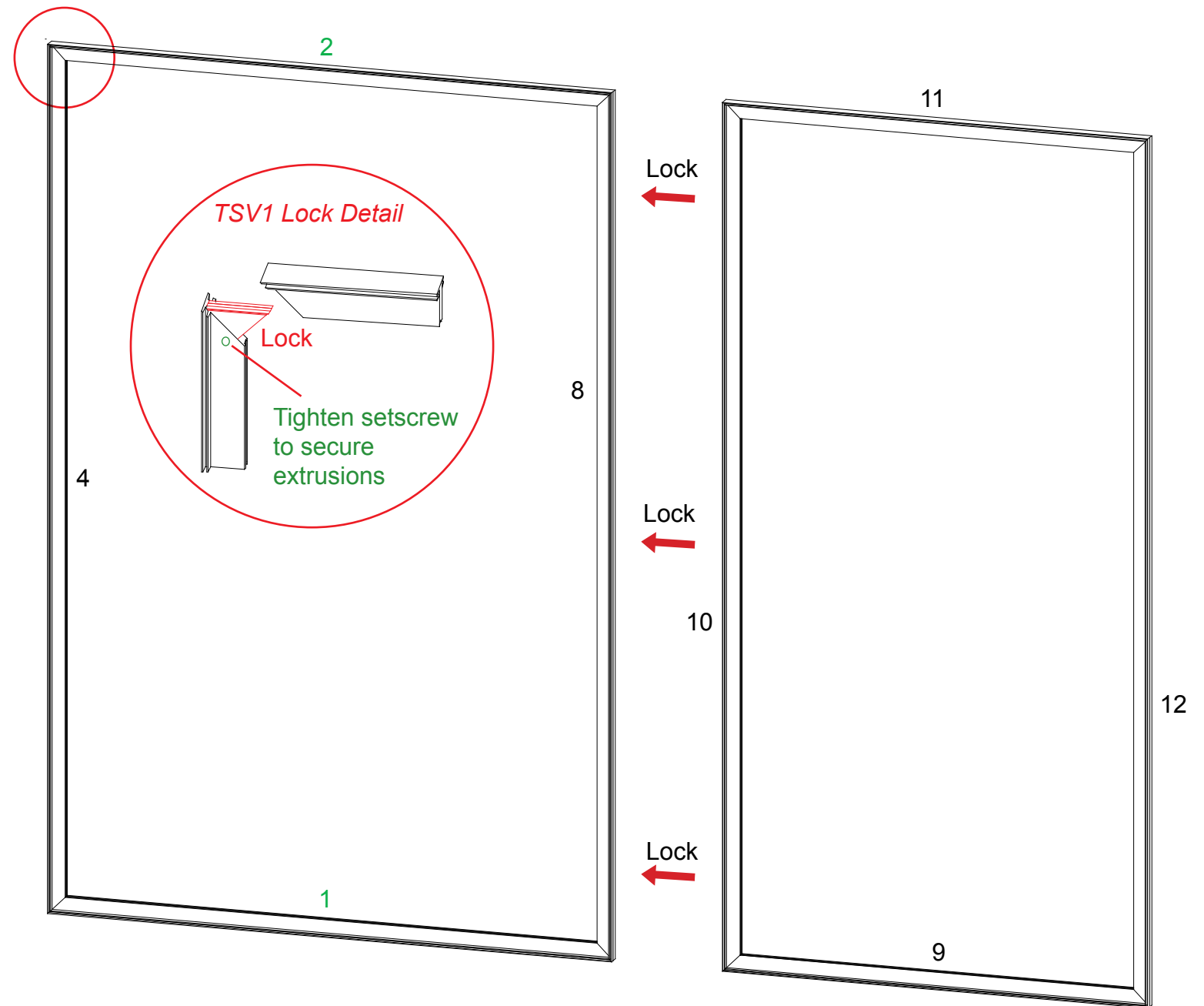

## Graphic: To Ensure Proper Fit

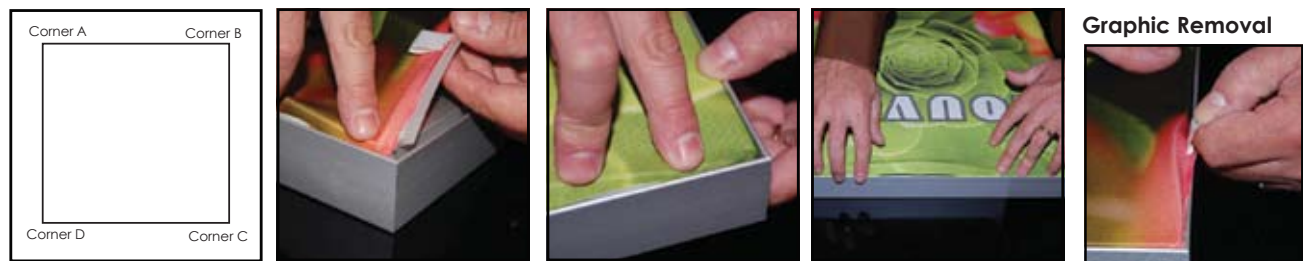

**It is important to first insert graphic into each alternate corner then to the sides of the frame. If this is not done, graphic will not fit into the frame correctly.**

**Step 1**  
Insert corner A. Turn edge of graphic so silicon welt is perpendicular to face of graphic. Insert narrow side of welt with fabric to outside into the channel. Repeat for other side of this corner.

**Step 2**  
Repeat Step 1 for opposite corner C, then insert corner B, followed by corner D, to complete the installation of the corners.

**Step 3**  
Once all corners are inserted, press one silicon edge into channel from corners and work toward the center. Make sure welt is fully inserted into channel. Continue until all sides are done. Smooth out edges of graphic.

To remove the graphic from the frame, locate the fabric pull tab. Gently pull up on the tab to remove the fabric.

**WHEN DISASSEMBLING ALUMINUM EXTRUSION, TIGHTEN ALL SETSCREWS AND LOCKS TO PREVENT LOSS DURING SHIPPING**

866.652.2100

Item	Qty.	Description
3	2	88.83" Vertical Extrusion
13/13a	2/2	96" Vertical Extrusion
14/14a	2/2	93" Horizontal Extrusion
15	4	88.83" Vertical Extrusion

Steps:

- 1) Lock assembled SEG frames to vertical extrusions [13a].
- 2) Attach horizontal extrusions [14] between verticals [13].
- 3) Attach extrusions [15 and 3] to center top of groove of horizontal [14] as shown.
- 4) Connect [14a] between verticals and on top of [15 and 3].
- 5) Attach pins to extrusions [14a] for curtains. Refer to detail.

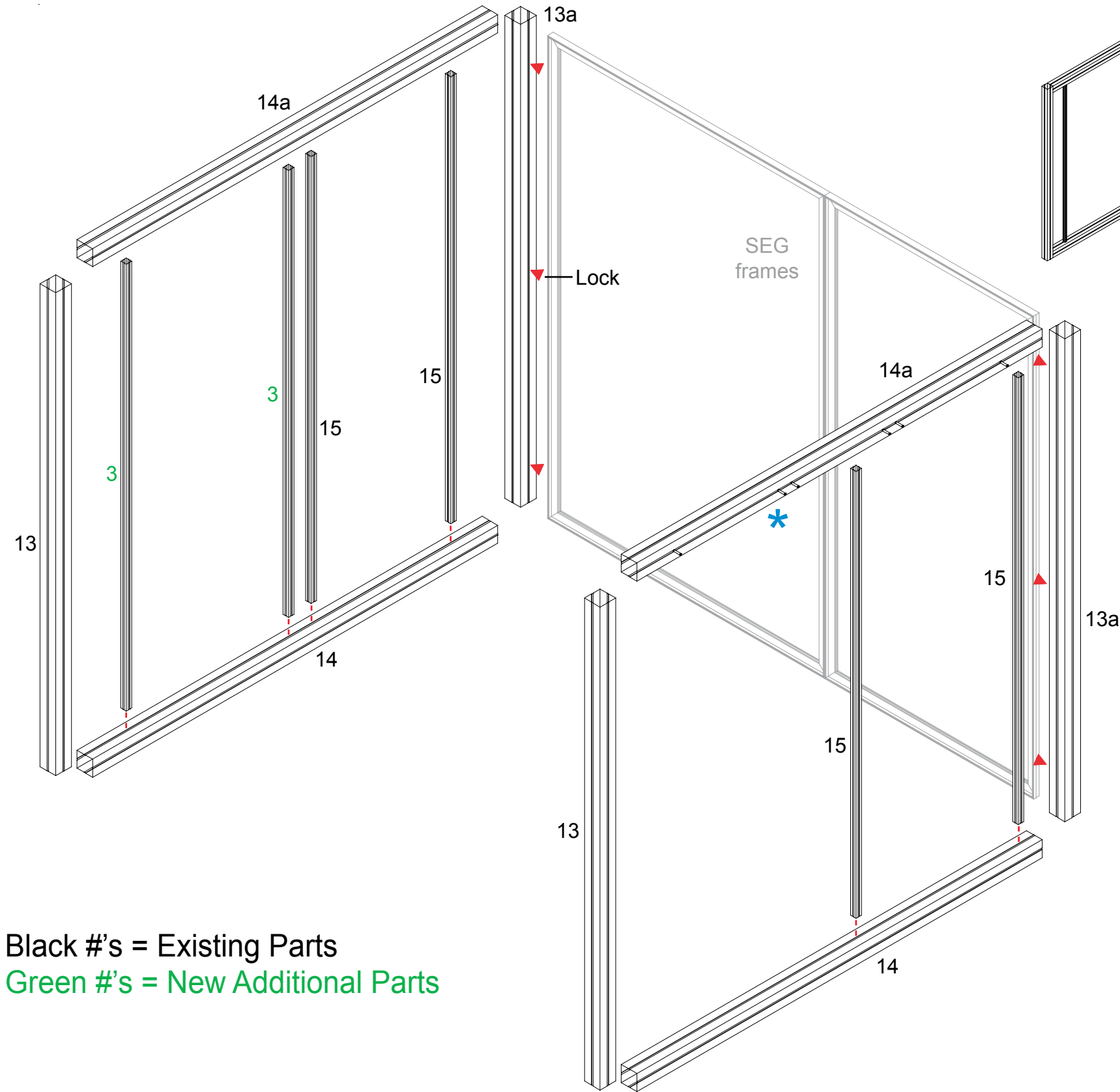
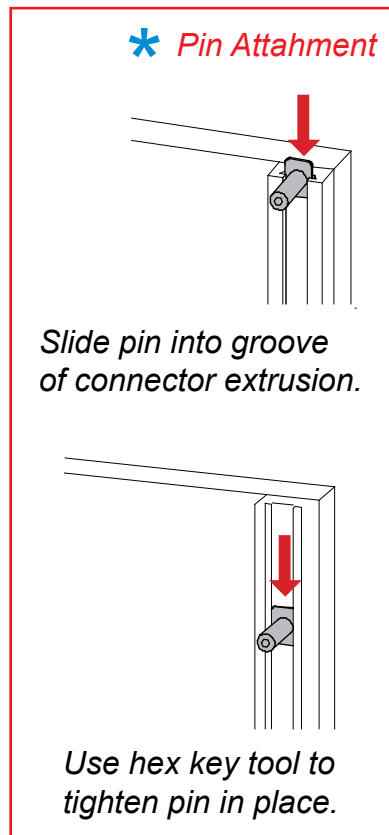

WHEN DISASSEMBLING ALUMINUM EXTRUSION, TIGHTEN ALL SETSCREWS AND LOCKS TO PREVENT LOSS DURING SHIPPING

866.652.2100

Item	Qty.	Description
4	4	Shelf Support Extrusion
25	4	Shelf Support Extrusion
A-E	1 ea.	White Sintra Sheets

Steps:

- 1) Attach shelf supports to vertical extrusions [15 and 3]. Refer to detail.
- 2) Place shelf atop shelf supports and secure with stand-off caps.
- 3) Attach pins to extrusions [14a] for curtains. Refer to detail.
- 4) Attach white sintra sheets to backwall. See next pg. for instructions.

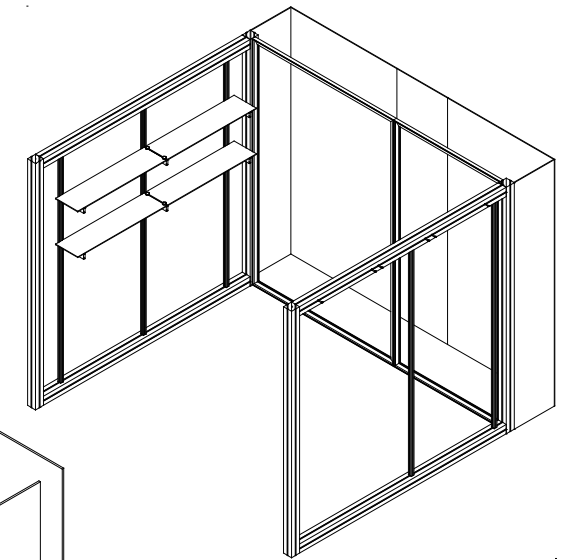
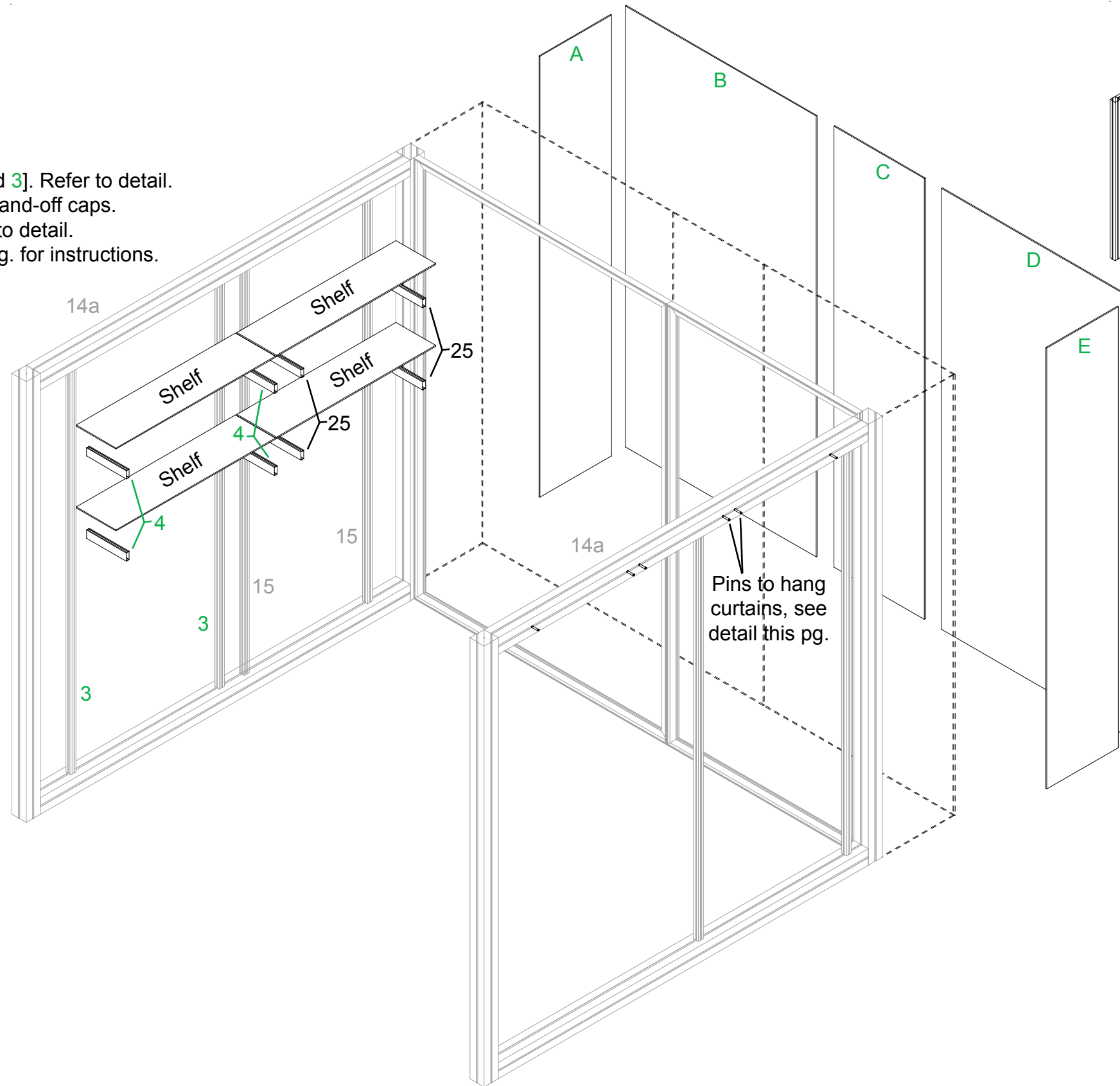

**Shelf Attachment**

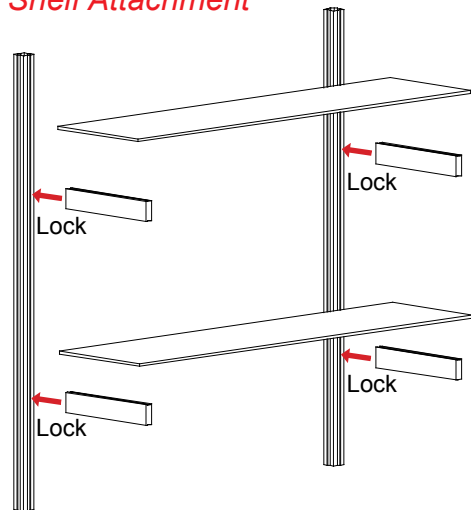

Lock shelf supports to groove of vertical extrusions.  
Set shelves atop supports

**Mirror Curtain Attachment**

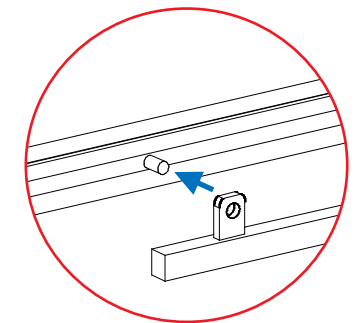

Adjust pins for desired width

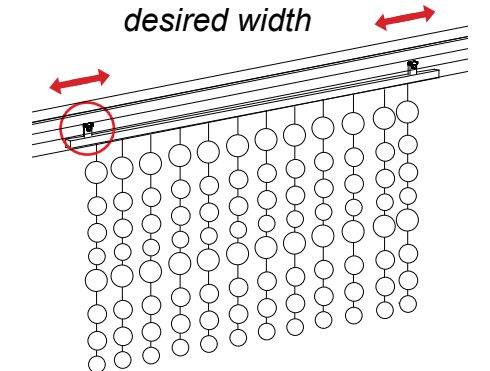

**WHEN DISASSEMBLING ALUMINUM EXTRUSION, TIGHTEN ALL SETSCREWS AND LOCKS TO PREVENT LOSS DURING SHIPPING**

866.652.2100

Item	Qty.	Description
5	6	40" h Vertical Square Extrusion
6	2	15" w Lower Horizontal Extrusion
7	2	36" w Lower Horizontal Extrusion
8	2	36" w Lower Horizontal Extrusion with attached plastic extrusion
9	2	15" w Upper Horizontal Extrusion
10	2	36" w Upper Horizontal Extrusion
11	2	36" w Upper Horizontal Extrusion with attached plastic extrusion

Black #'s = Existing Parts  
 Green #'s = New Additional Parts

Steps:

- 1) Attach lower horizontal extrusions [6, 7, and 8] between vertical square extrusions [5] as shown below.
- 2) Slide infills into groove between verticals. Note: Sliding doors must slide between horizontal extrusions [8 and 11].
- 3) Attach upper horizontal extrusions [9, 10, 11] between vertical extrusions [5] as shown.
- 4) Place counter top atop assembled counter.

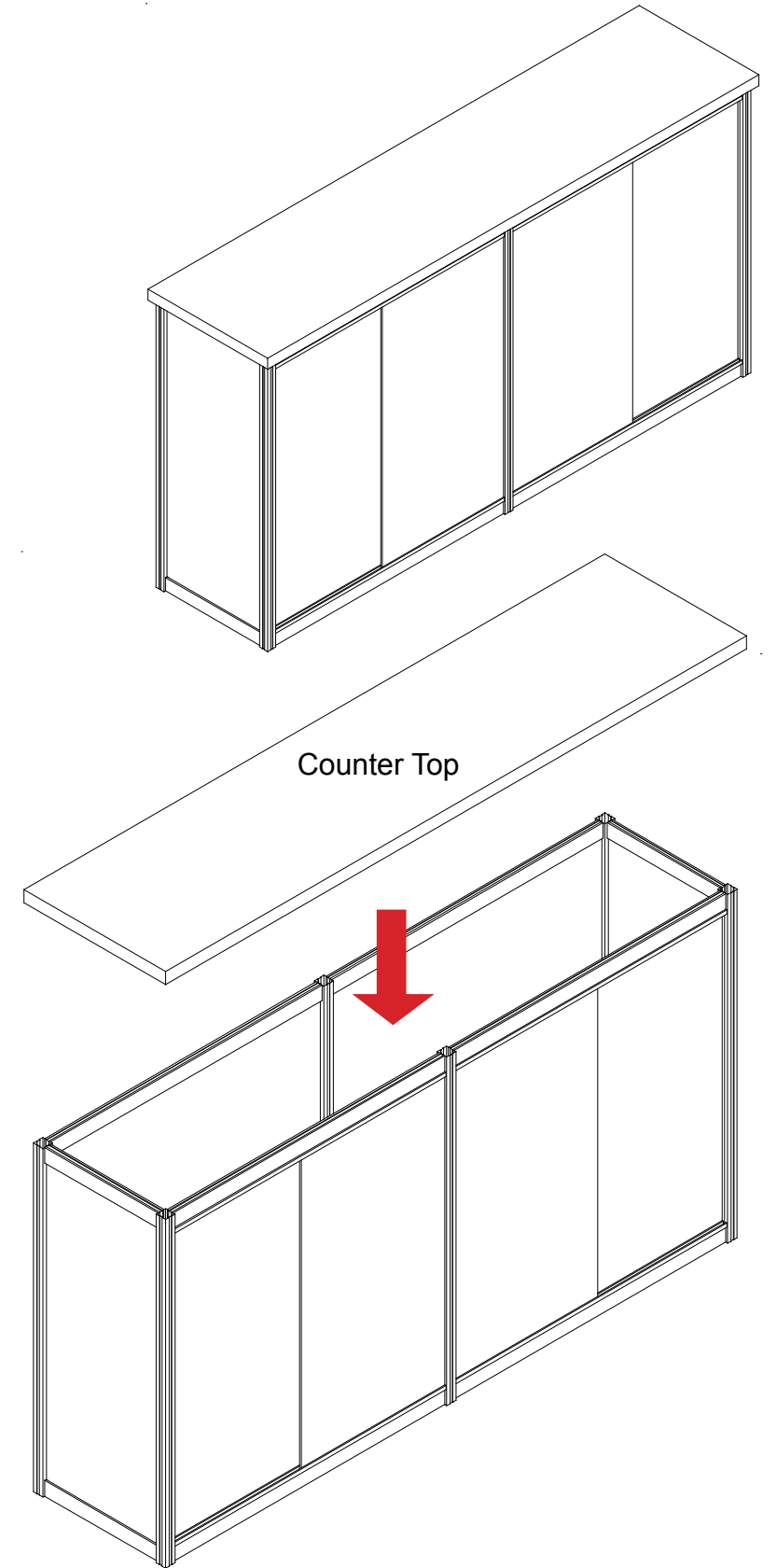
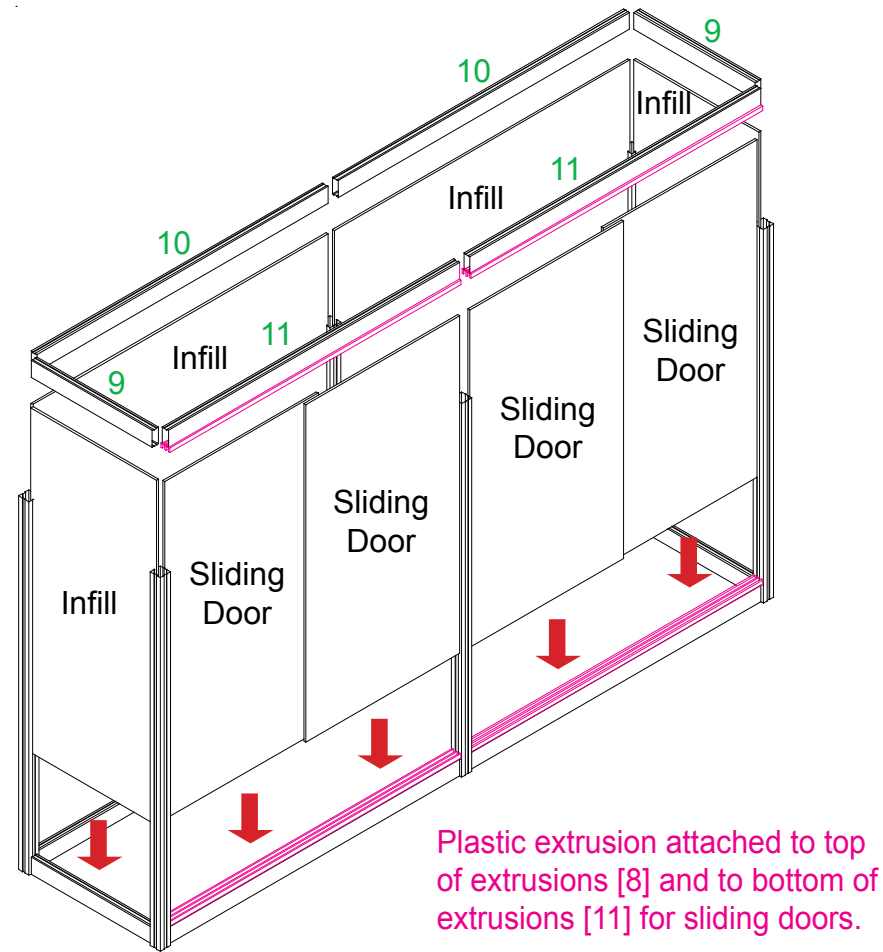
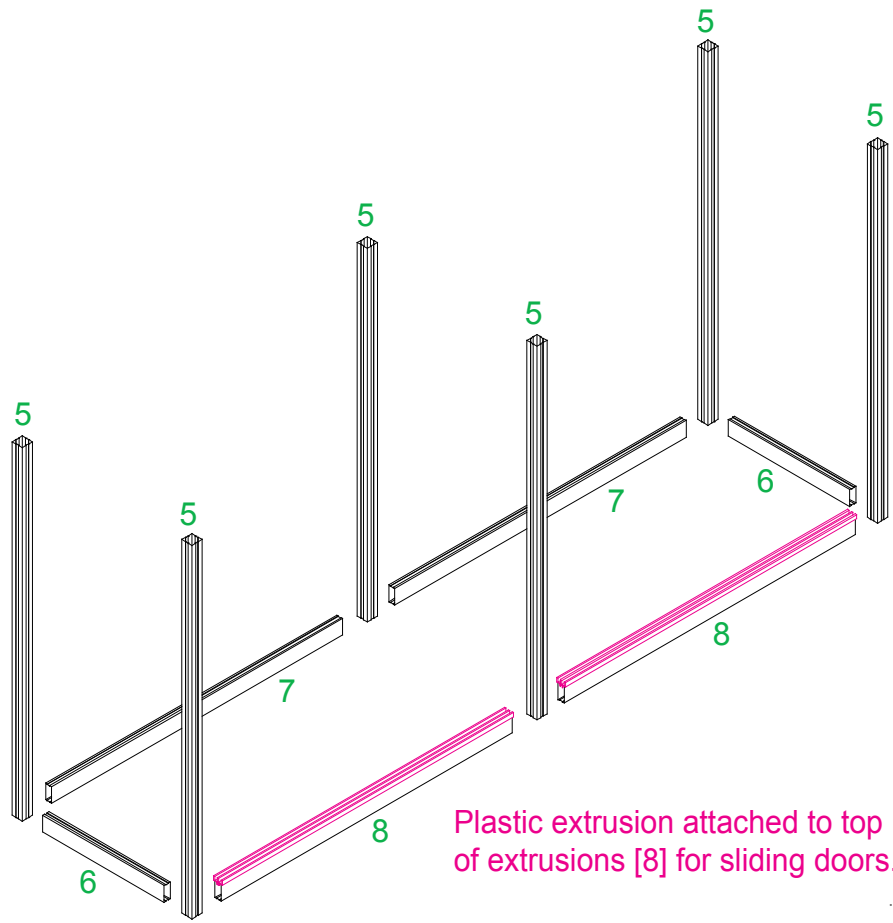

WHEN DISASSEMBLING ALUMINUM EXTRUSION, TIGHTEN ALL SETSCREWS AND LOCKS TO PREVENT LOSS DURING SHIPPING

866.652.2100

Item	Qty.	Description
A-E	1 ea.	White Sintra Sheets

Steps:

- 1) Snap panels [B, C, and D] flat on floor.
- 2) Snap panels [A and E] perpendicular to [B, C, and D] as shown below.
- 3) Rotate assembled section up as shown below.
- 4) Attach assembled section with A-10 Clips at bottom and top. Refer to detail.  
Note: Four total A-10 Clips. Two on each side (left and right) of booth.

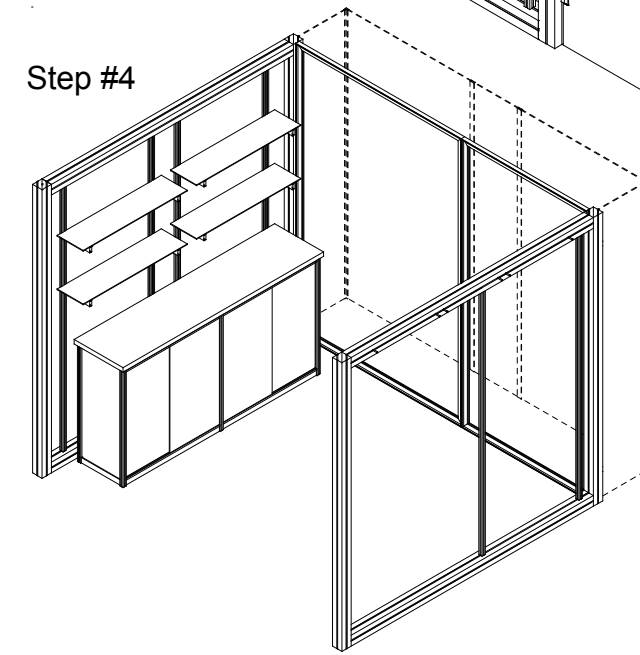
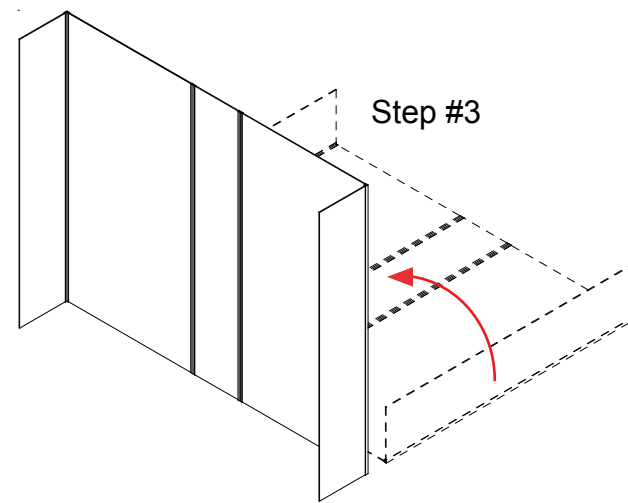
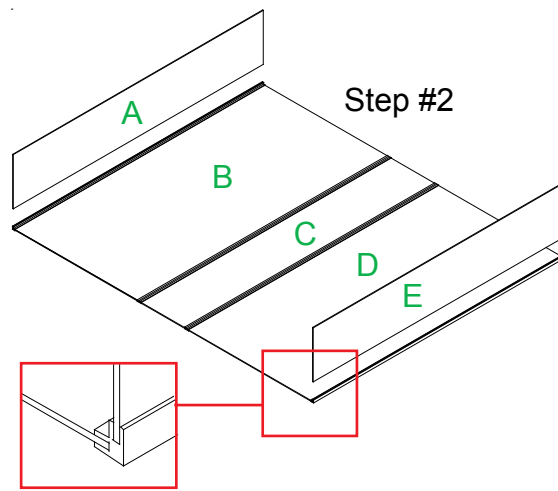
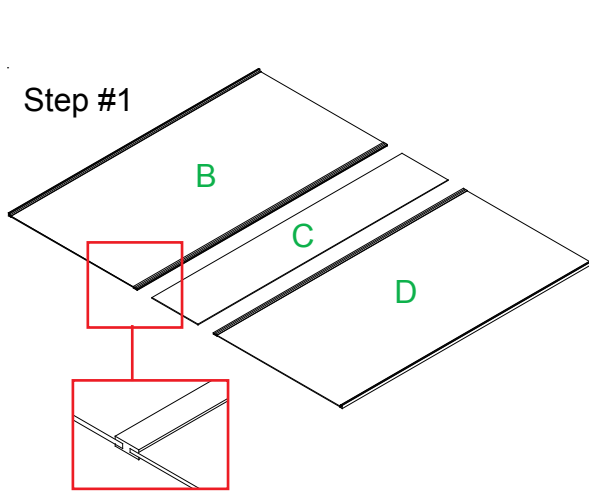
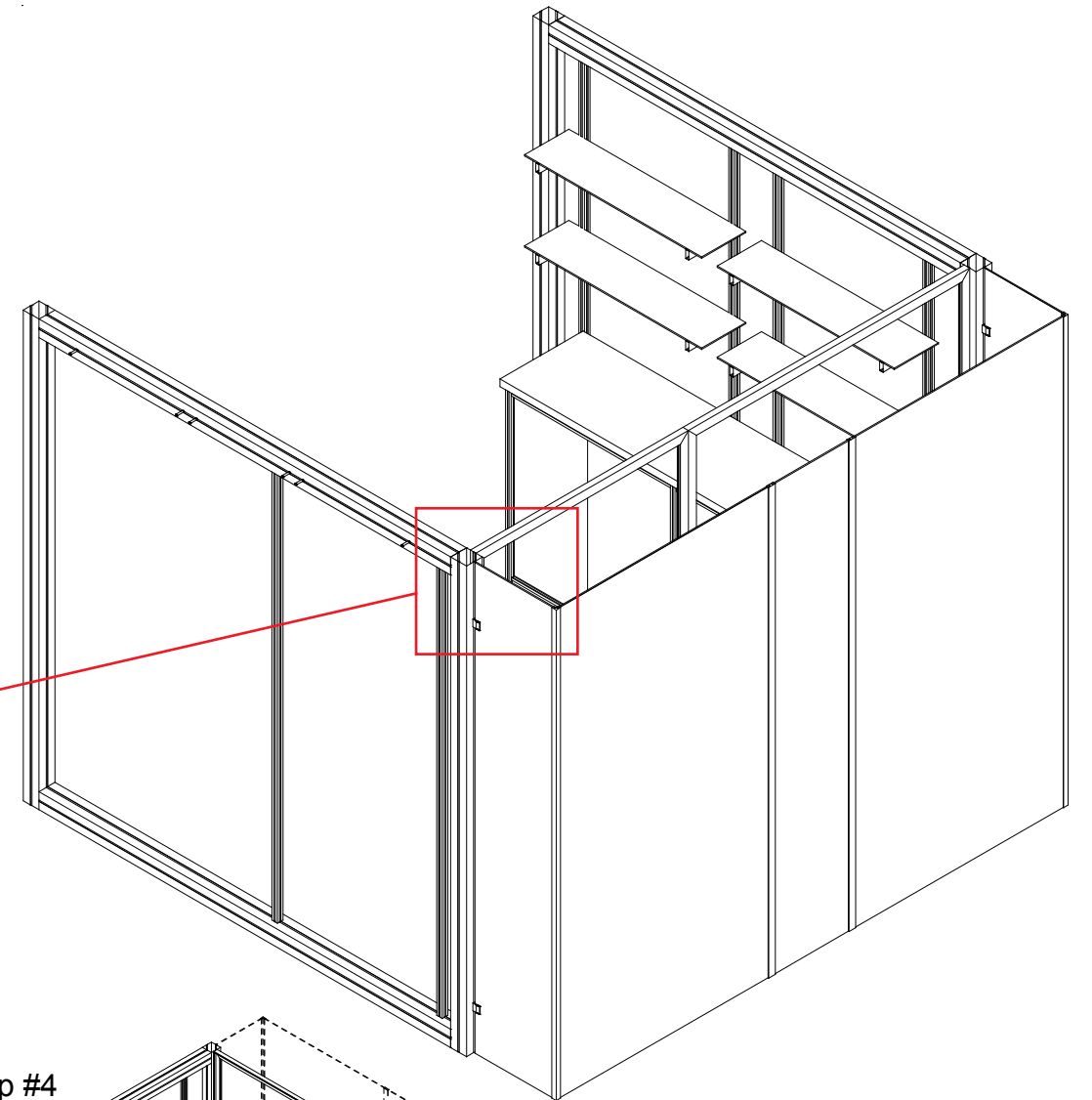
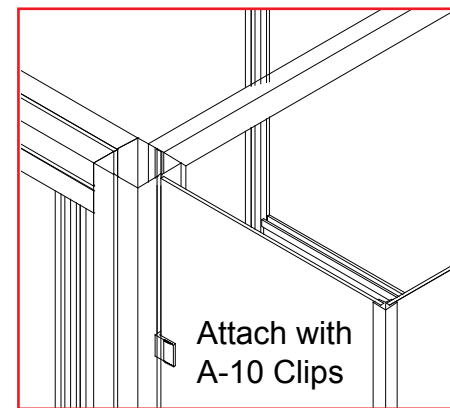
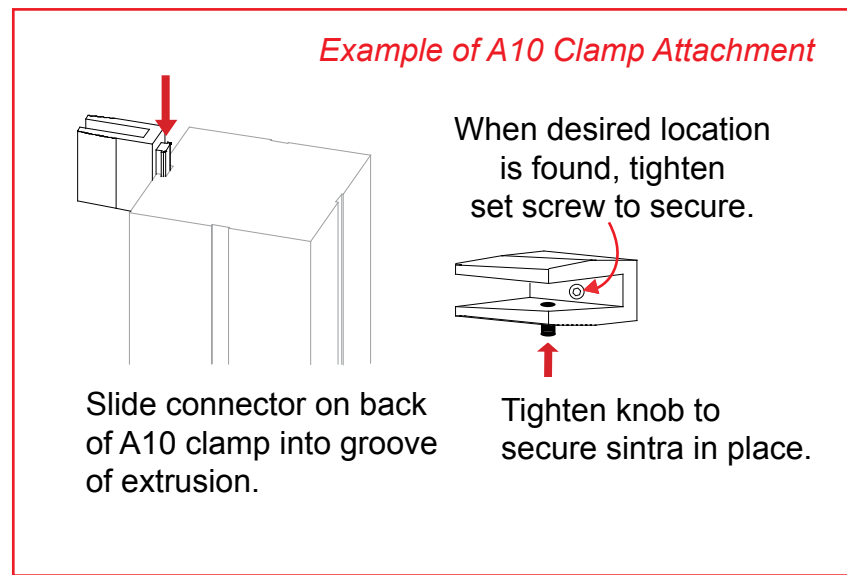

**WHEN DISASSEMBLING ALUMINUM EXTRUSION, TIGHTEN ALL SETSCREWS AND LOCKS TO PREVENT LOSS DURING SHIPPING**