

# Perfect 10 Hybrid Displays

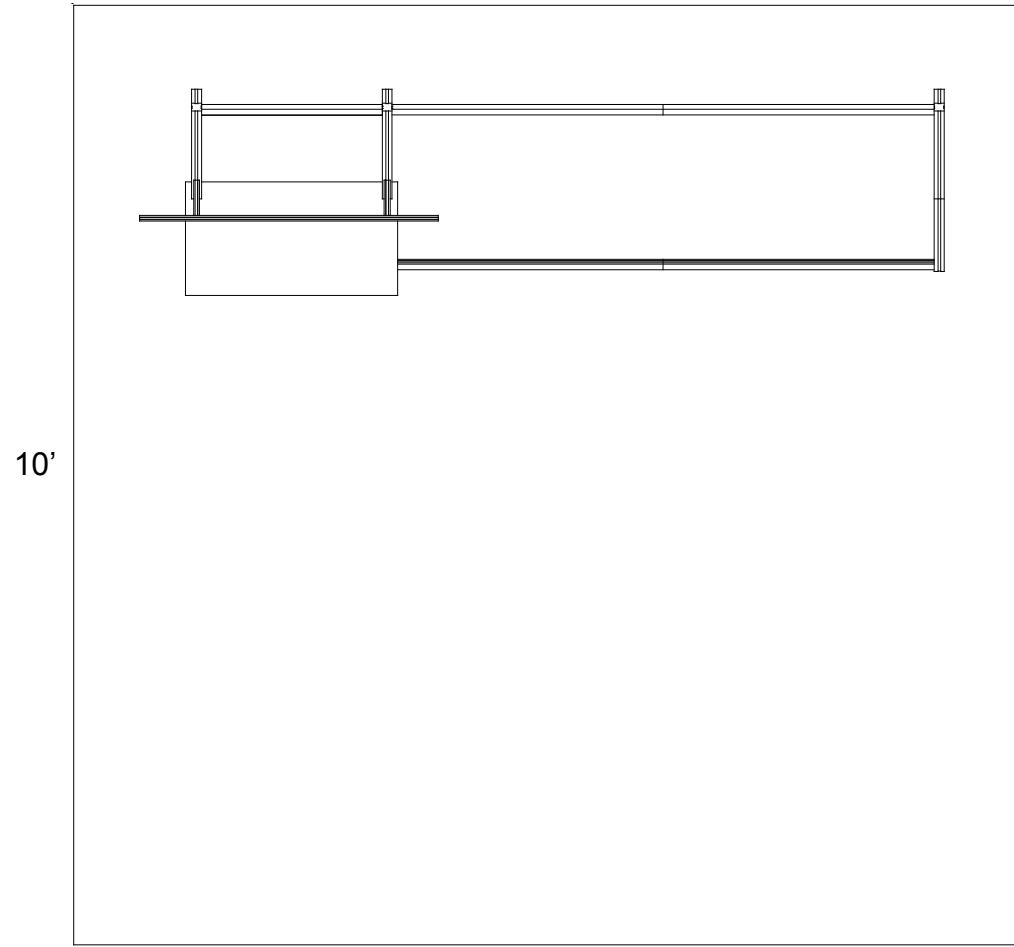

10'

Plan View

10'

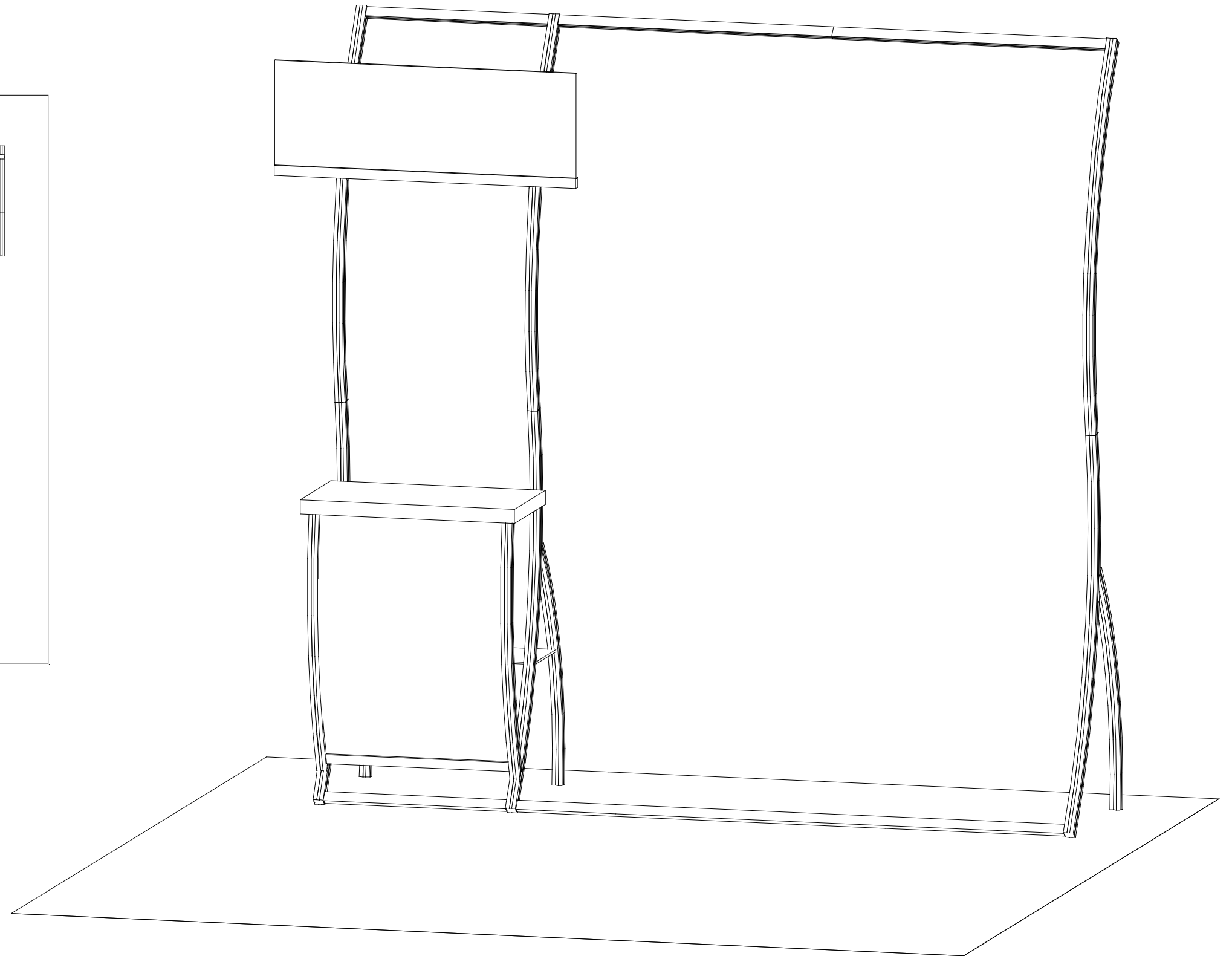

WHEN DISASSEMBLING TIGHTEN ALL KNOBS TO PREVENT LOSS DURING SHIPPING

866.652.2100

Part Number	Description
1	Left Leg Assembly
2	Middle Leg Assembly
3	Upper Curved Vertical
3A	Upper Curved Vertical
4	23" w Horizontal
9	Side Assembly
10	Side Assembly
11	Lower/Upper Horizontal Extrusion

NOTE: When assembling horizontals they should be placed approximately one inch from TOP and BOTTOM.



Step 1

Step 1:

NOTE: Can be assembled either face down on floor then lifted upright or upright as shown in drawings.



- A) Connect vertical leg assemblies [1 and 2] together by connecting horizontal extrusion [4] between assemblies tightening BLACK knobs on backside of extrusion making sure Velcro faces toward BACK and placing it about one inch up from bottom and tightening.
- B) Connect vertical extrusions [3 and 3A] to leg assemblies [1 and 2] using vertical connection bar as shown.
- C) Connect upper horizontal extrusion [4] between verticals [3 and 3A] placing it atop stoppers.
- D) Attach side assemblies [9 and 10] to leg assemblies [1 and 2] making sure inserts are in place as shown, then connect horizontal extrusion [11] into grooves of curve extrusions [9 and 10].
- E) Slide infill between curve extrusions [9 and 10] and atop extrusion [11].
- F) Attach upper horizontal extrusion [11] between curve extrusions [9 and 10] and atop insert.

NOTE: Make sure the lock is flush with extrusion before tightening. If lock will not fully engage, gently rock lock and extrusion while turning knob until lock fully opens.

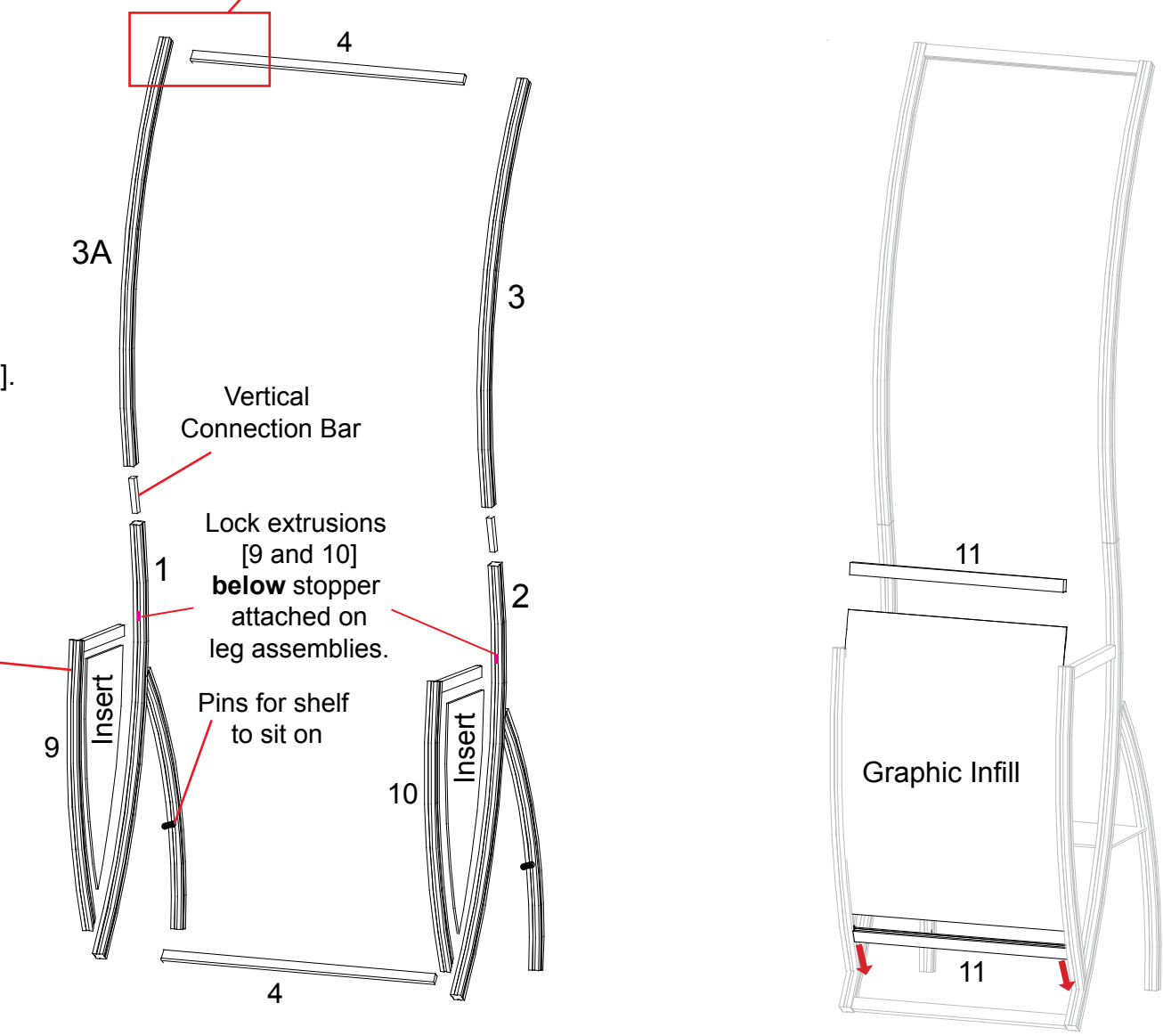

Rear View of Display

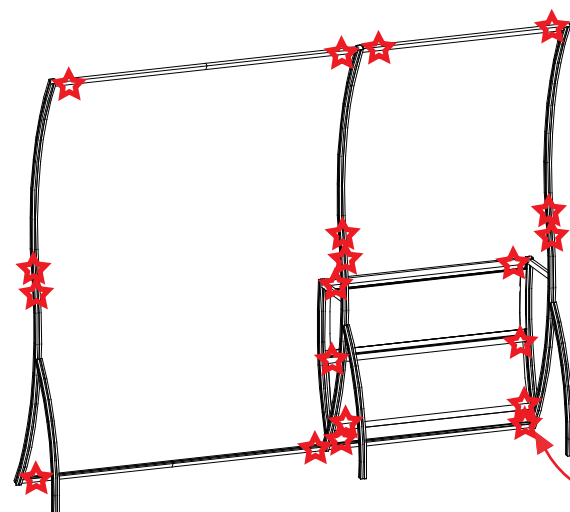

STAR indicates location of knobs on BACKSIDE of unit.

Extrusions 9 and 10 must stay assembled when shipping in case

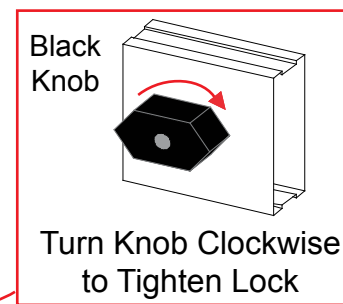

Turn Knob Clockwise to Tighten Lock

WHEN DISASSEMBLING TIGHTEN ALL KNOBS TO PREVENT LOSS DURING SHIPPING

866.652.2100

Part Number	Description
5	End Leg Assembly
6	Upper Curved Vertical
7	69" w Horizontal w/ Hinge Facing UP
8	69" w Horizontal w/ Hinge Facing DOWN

NOTE: When assembling horizontals they should be placed approximately one inch from TOP and BOTTOM.

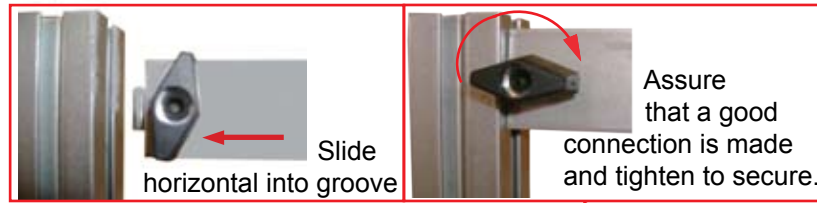

Step 2:

NOTE: Can be assembled either face down on floor then lifted upright or upright as shown in drawings.

A) Connect vertical extrusion [6] to leg assembly [5] using vertical connection bar as shown.

B) Connect horizontal extrusions [7 and 8] between vertical assemblies by tightening BLACK knobs on backside of extrusion making sure Velcro faces toward BACK.

NOTE: Make sure the lock is flush with extrusion before tightening. If lock will not fully engage, gently rock lock and extrusion while turning knob until lock fully opens.

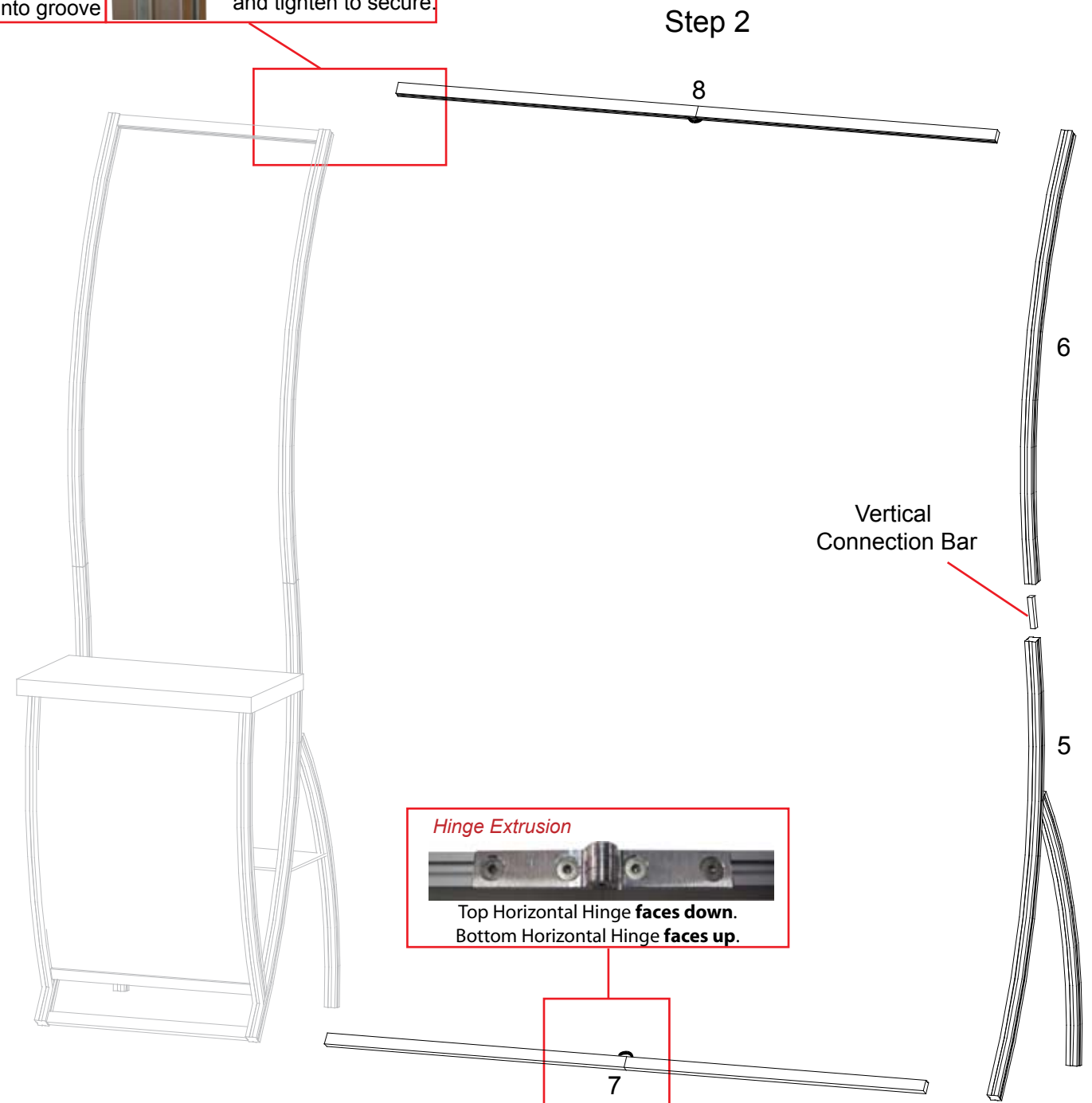

Rear View of Display

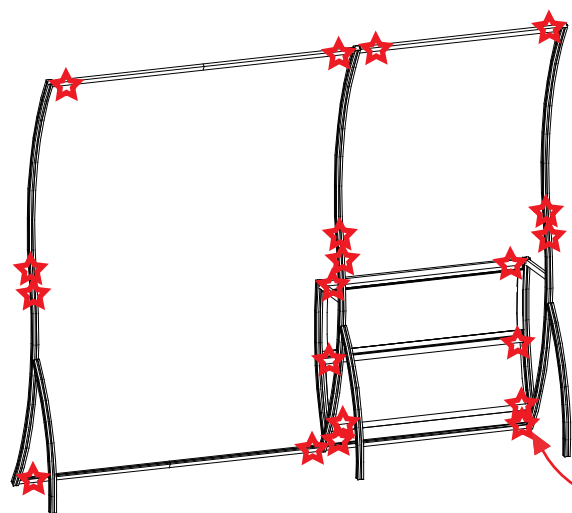

STAR indicates location of knobs on BACKSIDE of unit.

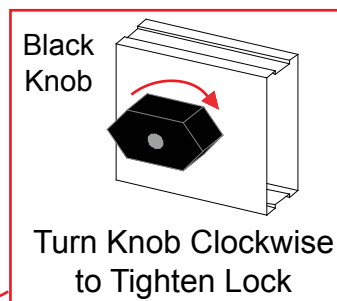

WHEN DISASSEMBLING TIGHTEN ALL KNOBS TO PREVENT LOSS DURING SHIPPING

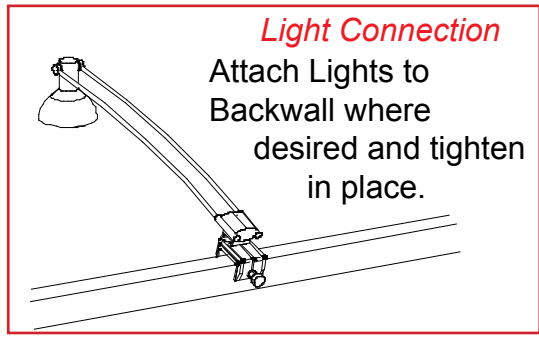
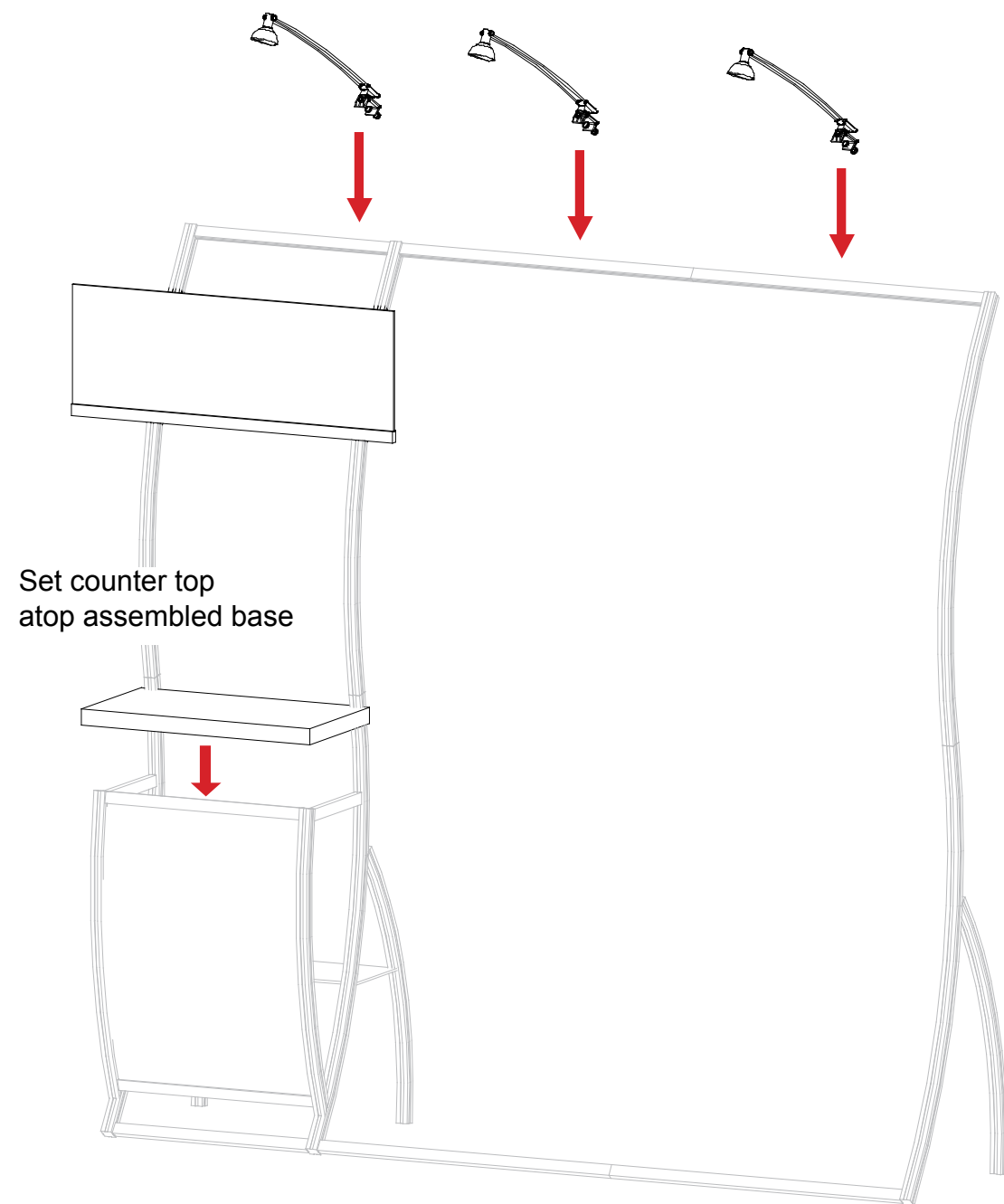
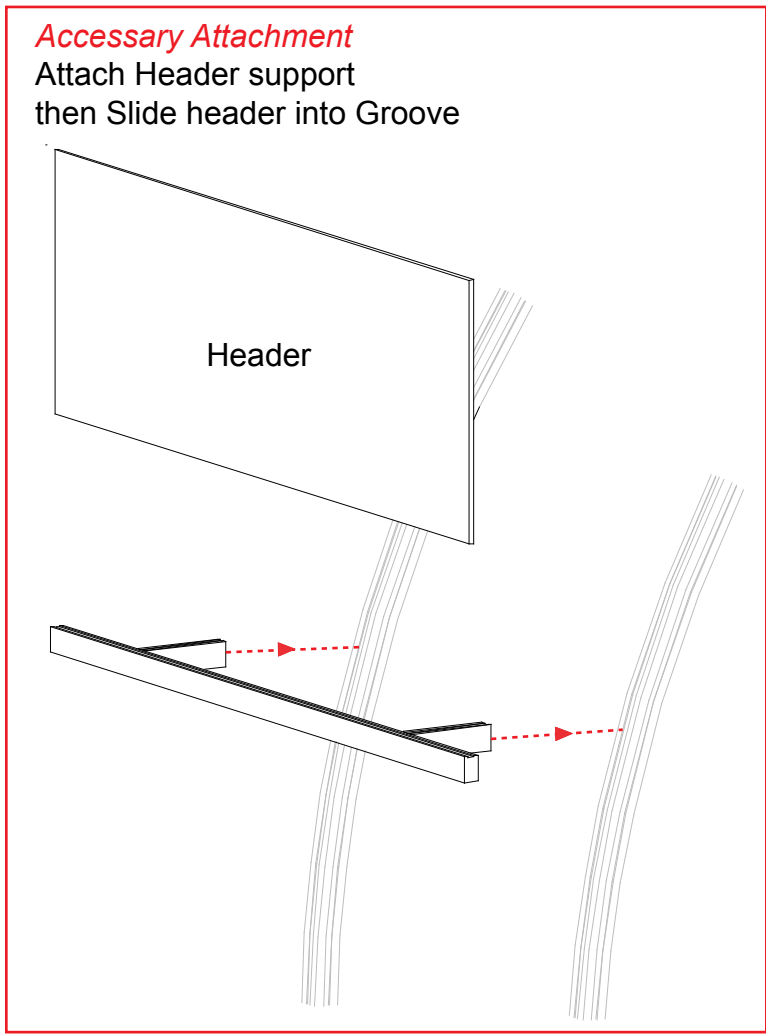

WHEN DISASSEMBLING TIGHTEN ALL KNOBS TO PREVENT LOSS DURING SHIPPING

Case #1 - Backwall Components

Top View of each Level

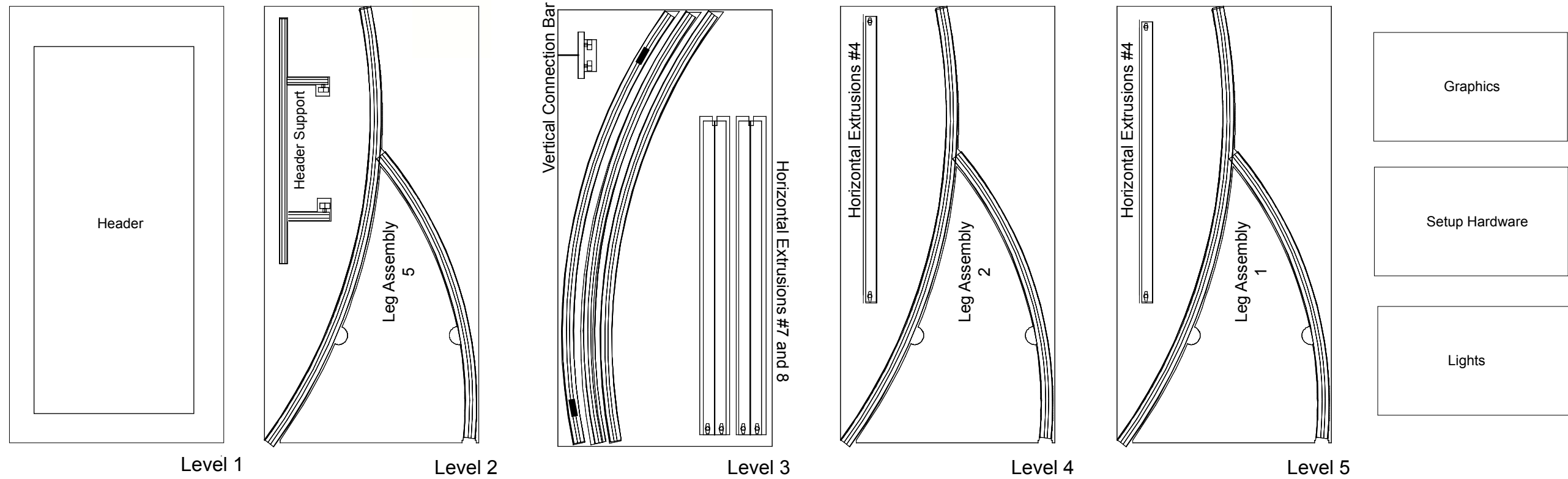

WHEN DISASSEMBLING TIGHTEN ALL KNOBS TO PREVENT LOSS DURING SHIPPING

Case #2 - Backwall Components

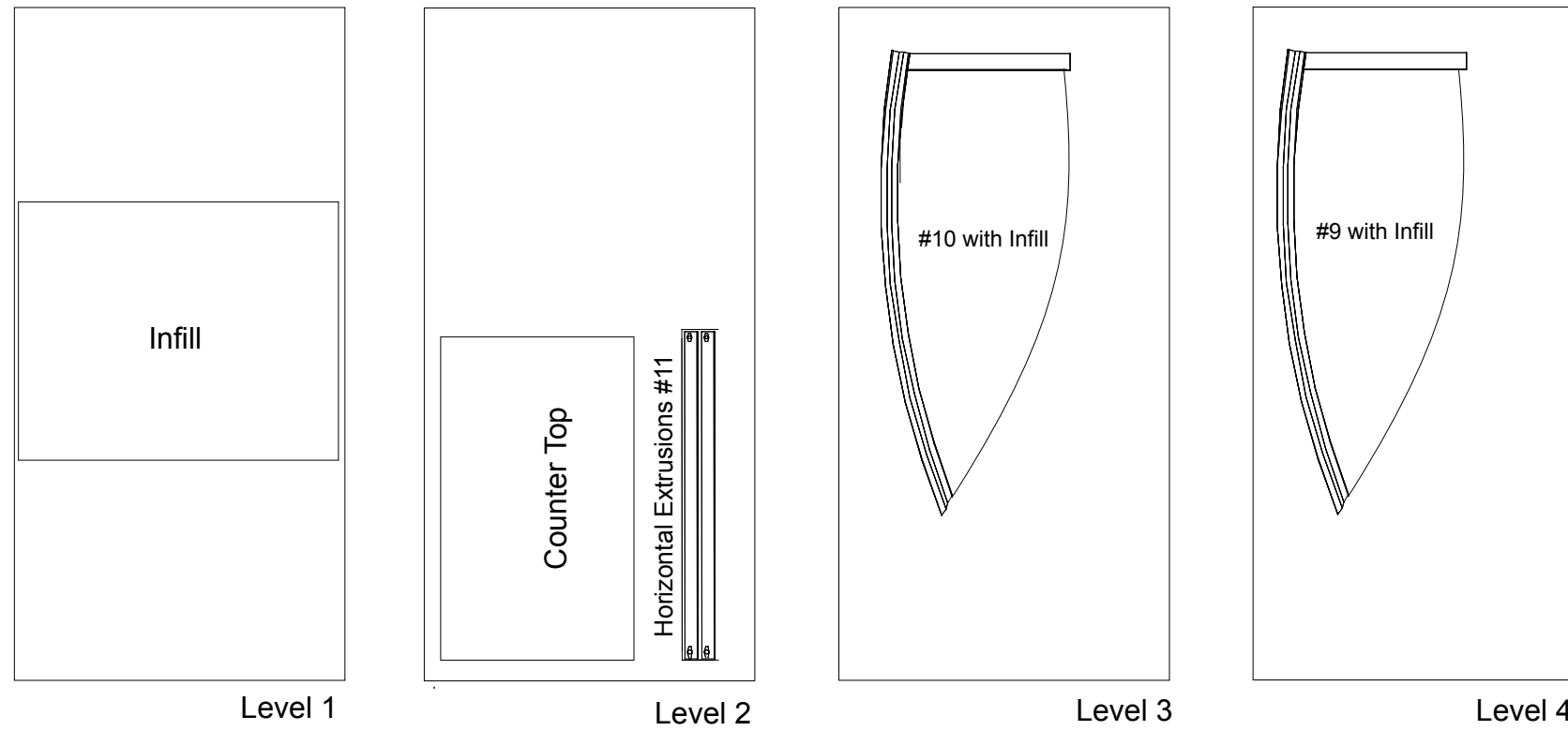

WHEN DISASSEMBLING TIGHTEN ALL KNOBS TO PREVENT LOSS DURING SHIPPING