

WHEN DISASSEMBLING ALUMINUM EXTRUSION, TIGHTEN ALL SETSCREWS AND LOCKS TO PREVENT LOSS DURING SHIPPING

visionary™ IDESIGNS

Using Your Setup Instructions

The Visionary Designs Setup Instructions are created specifically for your configuration. They are laid out sequentially, including an exploded view of the entire display, and then a logical series of detailed steps to assemble the main structure and components. We encourage you to study the instructions **before** attempting to assemble your exhibit.

Each page reminds you to tighten the setscrews after disassembling your exhibit to prevent loss of the locks and setscrews (see below in RED). This is **VERY IMPORTANT**.

Cleaning and Packing Your Display

- 1) Use care when cleaning aluminum extrusion or acrylic inserts. Use only non-abrasive cleaners.
- 2) When cleaning laminate inserts or countertops, use mild cleansers and a soft material such as cotton.
- 3) Keep all display components away from extreme heat and long exposure to sunlight to avoid warping and fading.
- 4) Retain all packing material. It will make re-packing much easier and will reduce the likelihood of shipping damage.



The Tool

Most Visionary Designs exhibits can be assembled with the supplied Hex Key Tool. Occasionally, a flat head screwdriver may be required.



Detail A

Typical Connection



Typical Connection (cont'd)

Most horizontal extrusion connections have a patented expandable lock. This lock inserts into the groove of an opposing extrusion. Tightening the lock with the Hex Key Tool expands the lock and creates a strong positive connection.

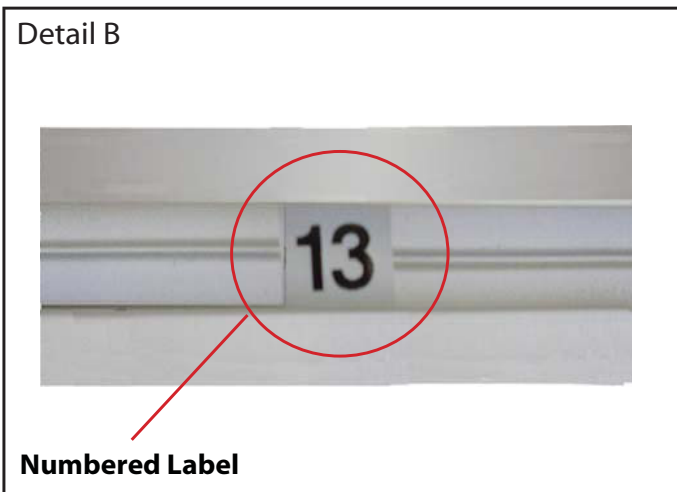

Detail B

Numbered Label

Each extrusion contains a numbered label which corresponds with setup instructions. The label is located within a groove of the extrusion (when possible). With Visionary Designs the labels contain Black numbers unless otherwise specified.



Detail C

Horizontal Inline Connection (remove only one setscrew)

Remove only (1) setscrew when disassembling. Replace setscrew in extrusion after assembling it. Before packing, replace setscrew in extrusion to avoid losing it.

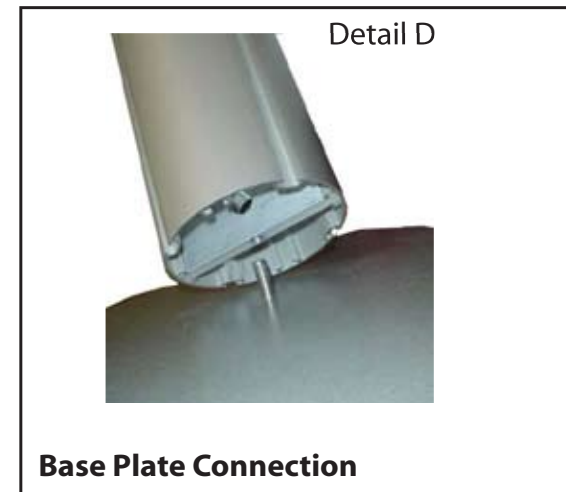

Detail D

Base Plate Connection

Attach base plate to round or square vertical extrusion using the bolt provided. Be careful not to strip the threads.

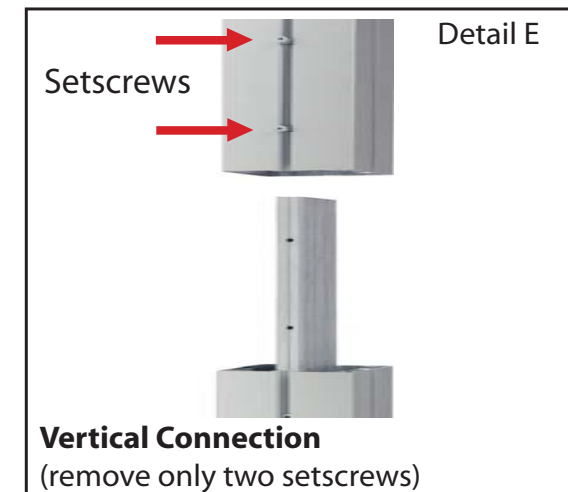

Detail E

Vertical Connection

(remove only two setscrews)

When vertical extrusions are packed in portable cases rather than crates or tubs, they must be broken down into smaller sections which then require assembly.

Remove only (2) setscrews when disassembling. Replace setscrews in extrusion after assembling it. Before packing, replace setscrews in extrusion to avoid losing them.



WHEN DISASSEMBLING ALUMINUM EXTRUSION, TIGHTEN ALL SETSCREWS AND LOCKS TO PREVENT LOSS DURING SHIPPING

Item	Qty.	Description
1	1	Lighted Base
2	1	Lighted Base
3	1	Lighted Base
4	1	Lighted Base
5	1	46" h Square Vertical Extrusion
6	1	46" h Square Vertical Extrusion
7	1	46" h Square Vertical Extrusion
8	1	46" h Square Vertical Extrusion
9	1	46" h Square Vertical Extrusion
10	1	46" h Square Vertical Extrusion
11	1	46" h Square Vertical Extrusion
12	1	46" h Square Vertical Extrusion
13	1	32" w Lower Horizontal Extrusion
14	1	32" w Upper Horizontal Extrusion
17	1	46" w Lower Horizontal Extrusion
18	1	46" w Lower Horizontal Extrusion
19	1	46" w Upper Horizontal Extrusion
20	1	46" w Upper Horizontal Extrusion

Steps:

- 1) Connect lighted bases [2, 3, & 4] together.
- 2) Attach upper vertical extrusions [8, 6, 10, & 12] to lower vertical extrusions [7, 5, 9, & 11].
- 3) Connect horizontal extrusions together [17 to 18] and [19 to 20].
- 4) Attach horizontal assemblies [17/18 & 19/20] between vertical assemblies [9/10 & 11/12].
- 5) Attach horizontal extrusions [13 & 14] between vertical assemblies [5/6 & 7/8].
- 6) Snap plastic wire covers into grooves of vertical extrusions [7 & 8].
- 7) Attach lighted base [1] to vertical extrusions [7 & 5] using bolts as shown.
- 8) Attach lighted base assembly [2/3/4] to vertical extrusions [9 & 11] using bolts as shown.

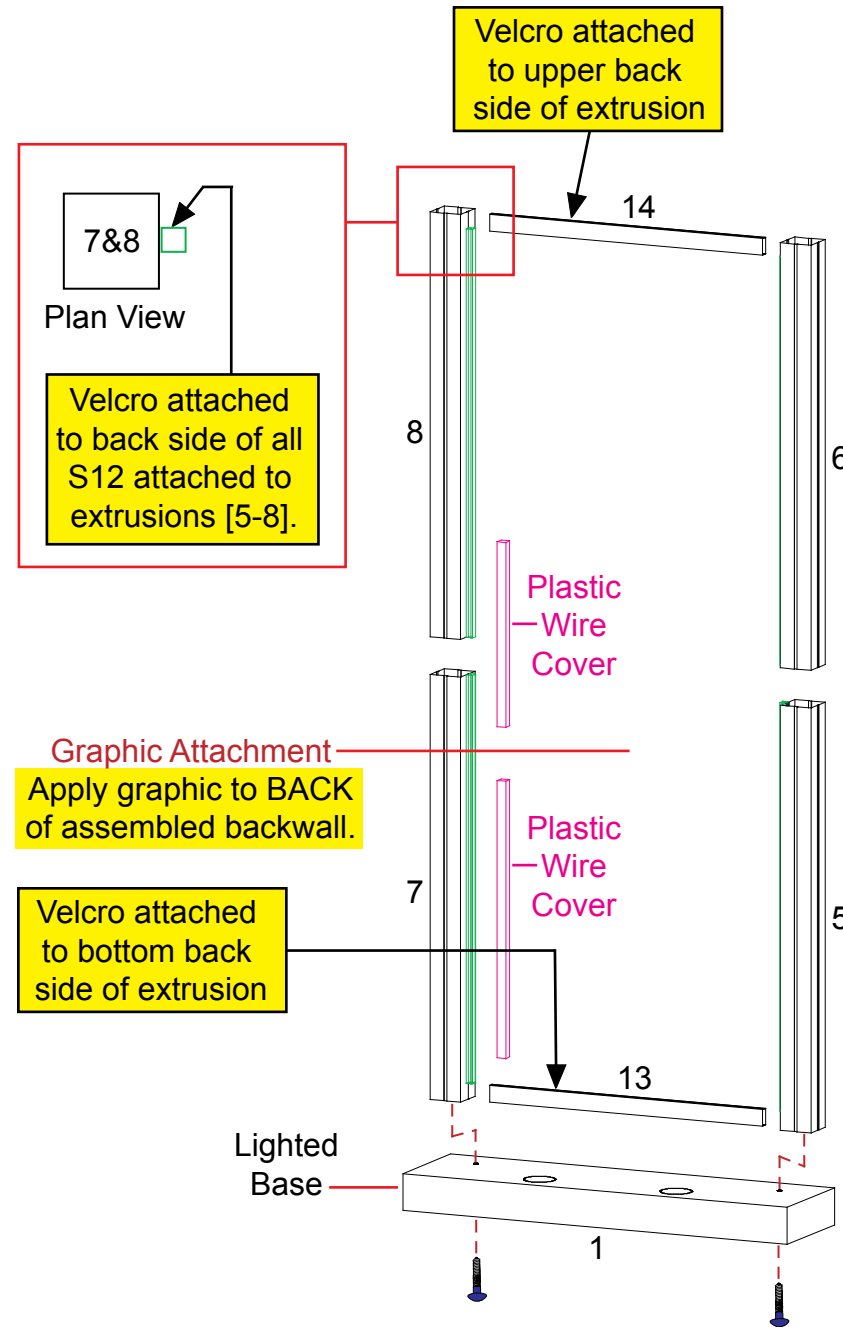
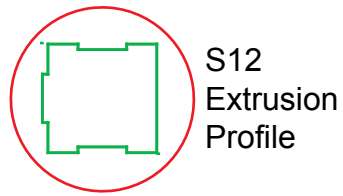

Note: Graphic wraps over and velcro attach to upper back side of upper horizontal extrusions [19 & 20].

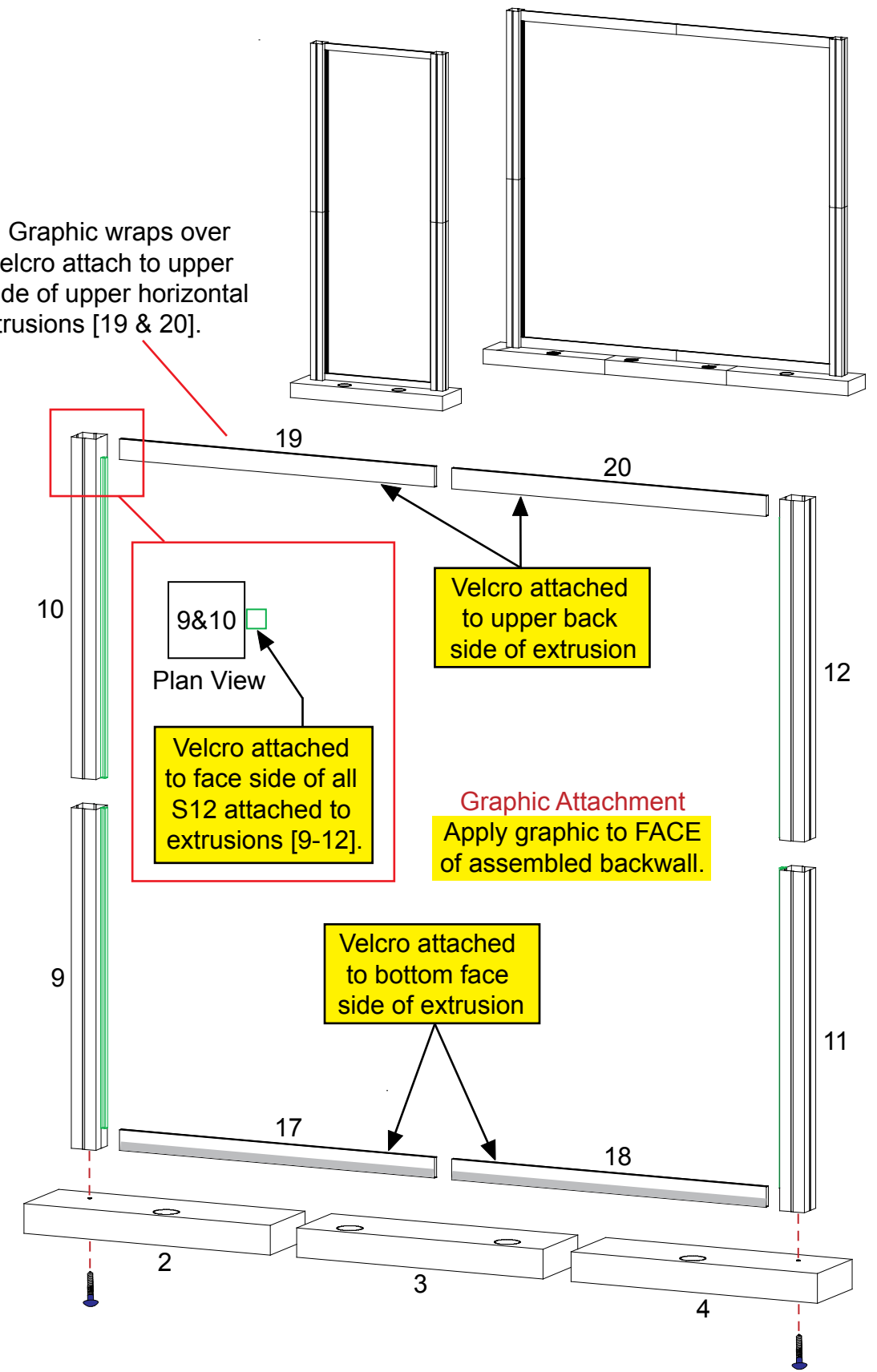

WHEN DISASSEMBLING ALUMINUM EXTRUSION, TIGHTEN ALL SETSCREWS AND LOCKS TO PREVENT LOSS DURING SHIPPING

Item	Qty.	Description
15	1	23"w Lower Horizontal Extrusion
16	1	23"w Upper Horizontal Extrusion
21	1	39.1650"x4" Horizontal Extrusion
22	2	9" Keyboard Shelf Support

Velcro for graphic attachment

Steps:

- 1) Attach lower and upper horizontal extrusions [15 & 16] between vertical assemblies [7/8 & 9/10].
- 2) Attach keyboard shelf supports [22] to vertical extrusions [5 & 7].
- 3) Velcro attach keyboard shelf atop shelf supports.
- 4) Velcro attach graphic round header to vertical extrusion [8] as shown.
- 5) Attach horizontal extrusion [21] to verticals [6 & 8]. Refer to *Plate to Post Attachment Example* detail.
- 6) Attach pamphlet tray to vertical. Refer to *Adjustable Pamphlet Tray Attachment* detail.
- 7) Attach lights to top of assembled backwall. Refer to *Light Connection* detail.
- 8) Attach monitor mount to horizontal extrusion [21]. Refer to *Monitor Mount Attachment* detail.

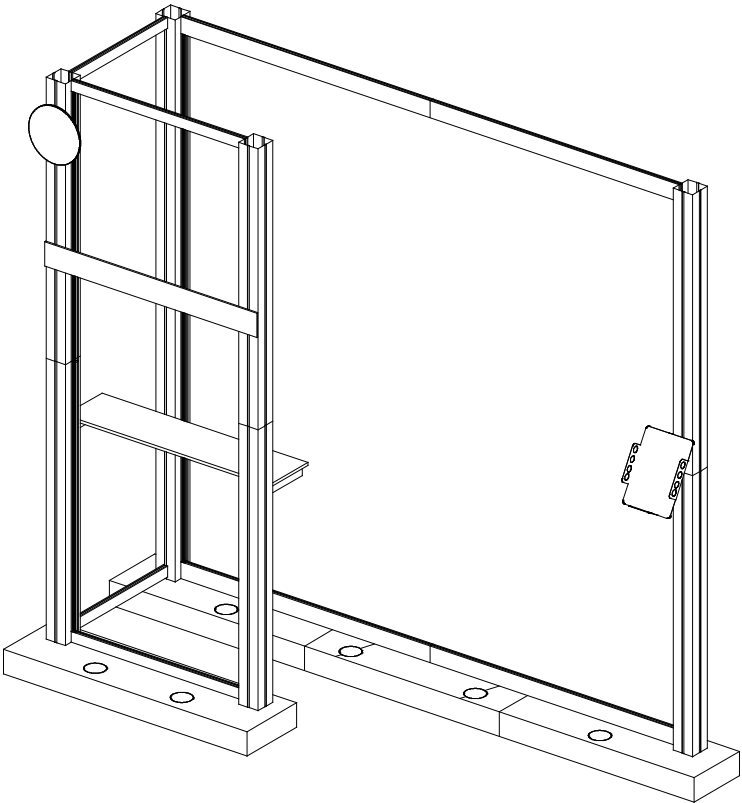
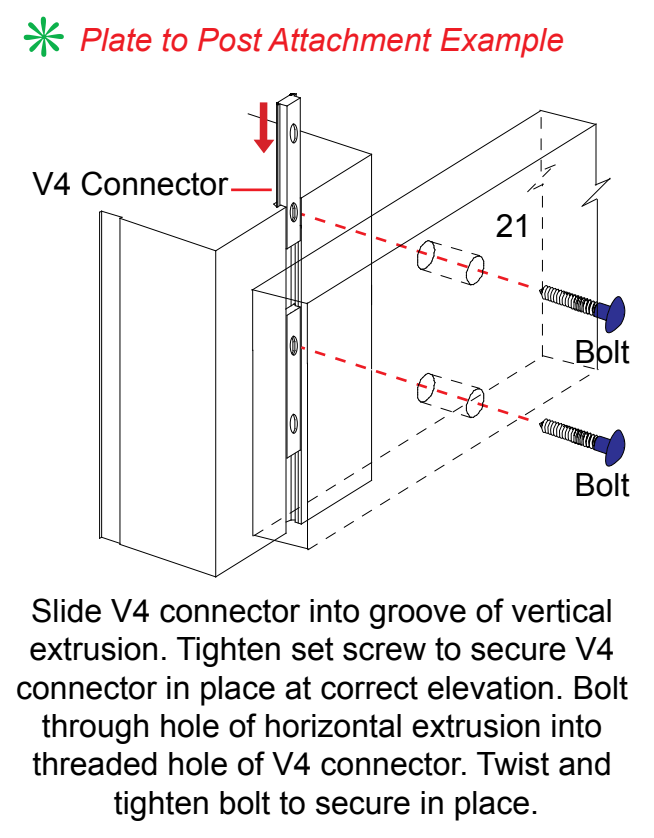
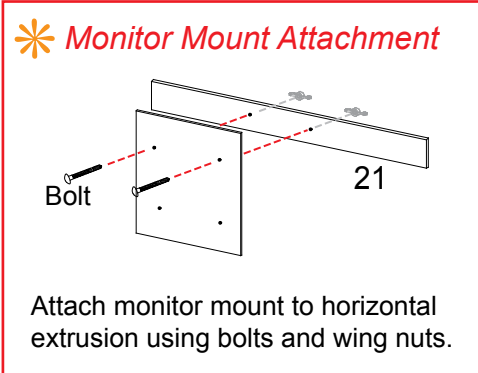
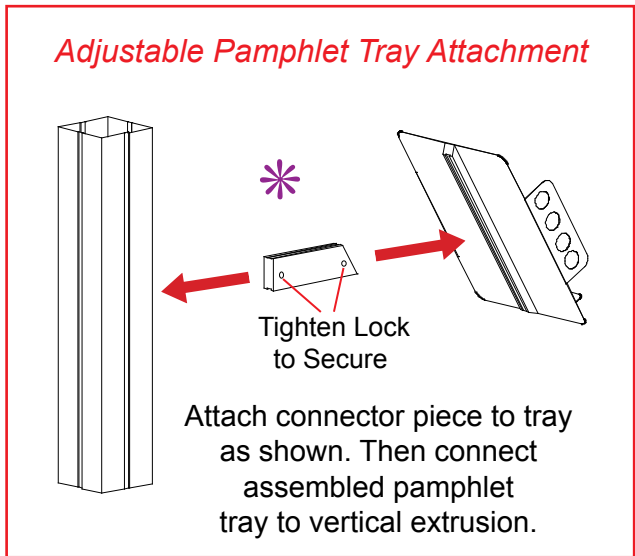
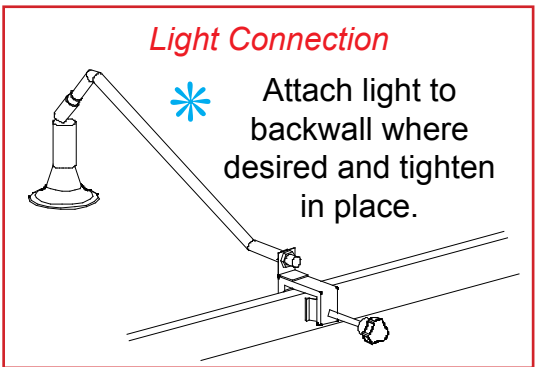
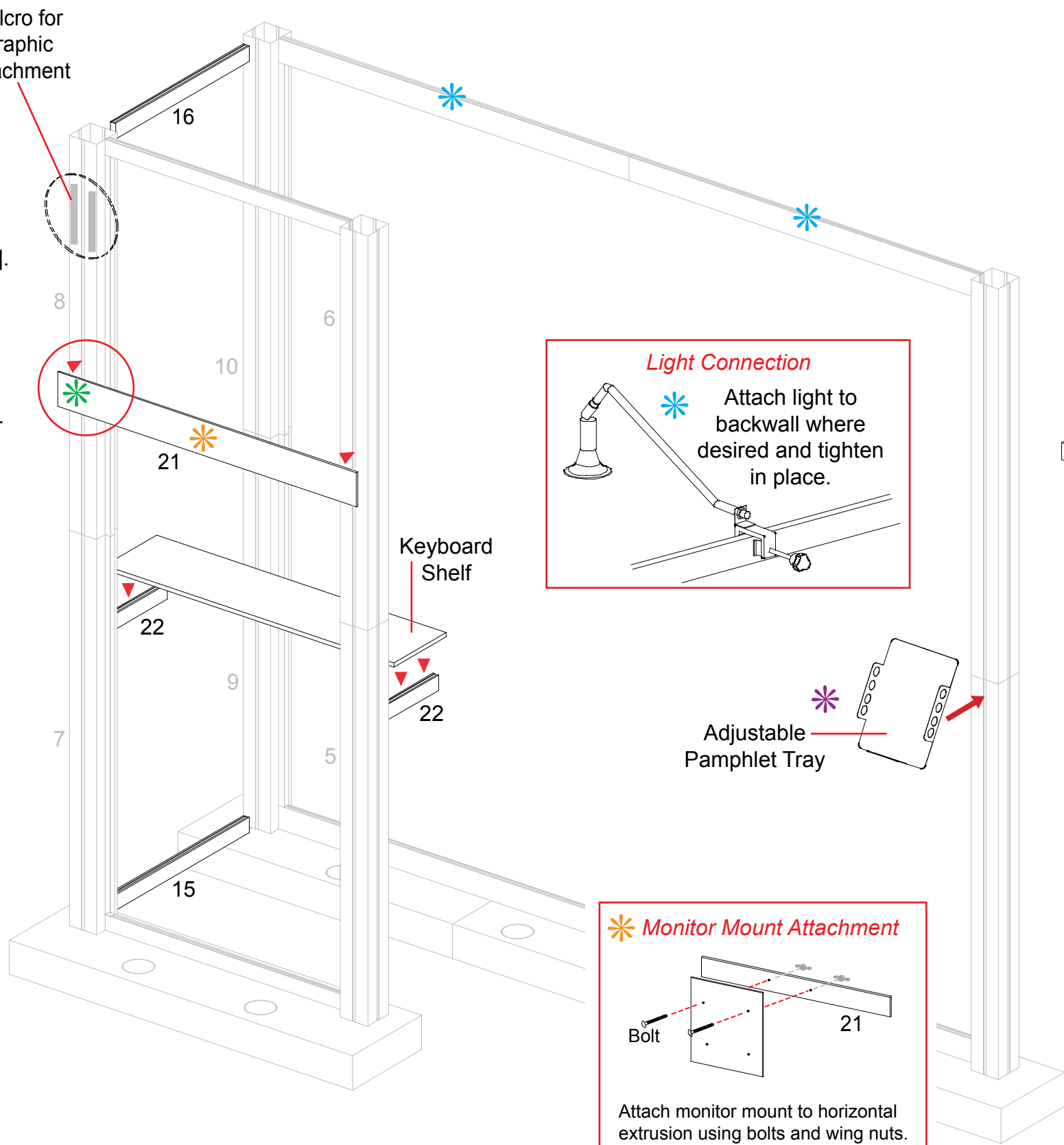

WHEN DISASSEMBLING ALUMINUM EXTRUSION, TIGHTEN ALL SETSCREWS AND LOCKS TO PREVENT LOSS DURING SHIPPING

Item	Qty.	Description
23	4	42" h Vertical Extrusion
24	2	25" w Horizontal Extrusion
25	2	17" w Horizontal Extrusion

- Steps:
- 1) Attach horizontal extrusions [24 & 25] between vertical extrusions [23].
 - 2) Place counter top atop assembled pedestal and secure in place.

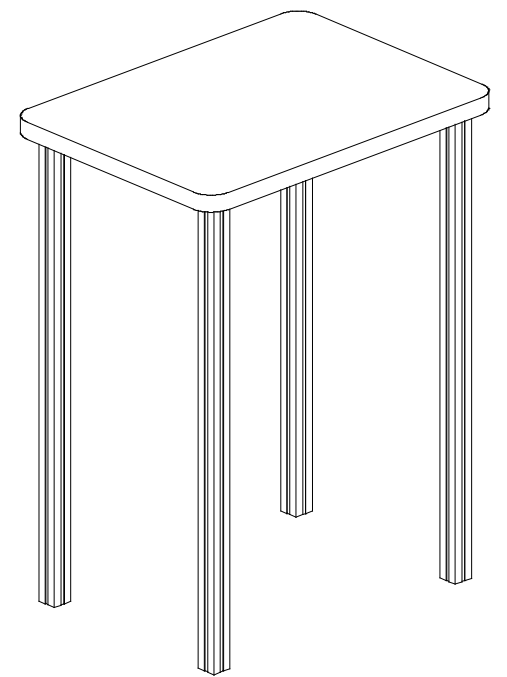
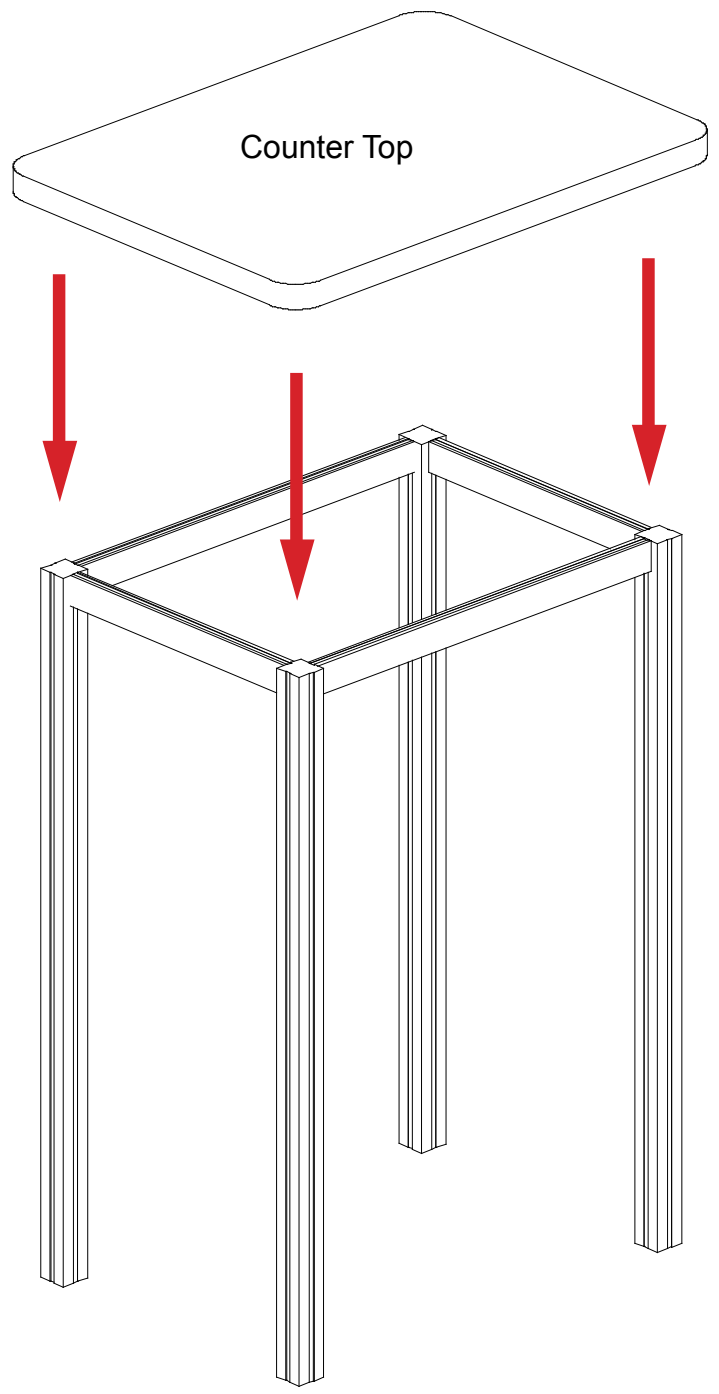
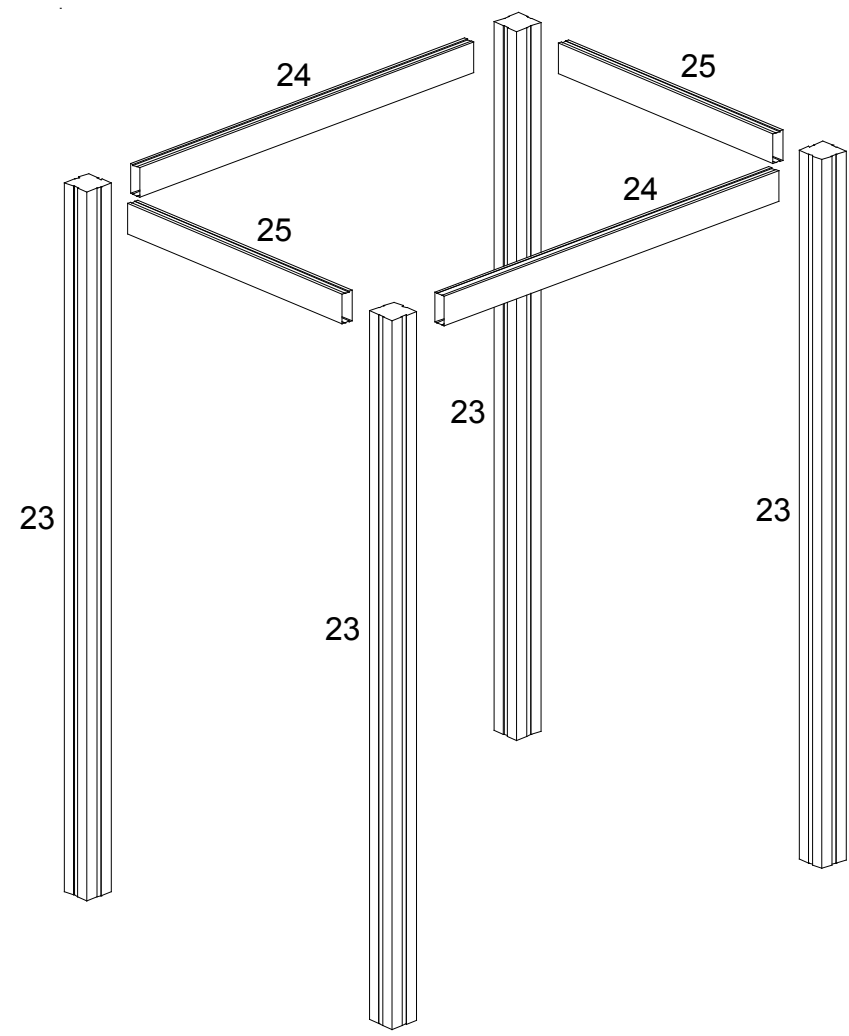

WHEN DISASSEMBLING ALUMINUM EXTRUSION, TIGHTEN ALL SETSCREWS AND LOCKS TO PREVENT LOSS DURING SHIPPING

Top View of Each Level

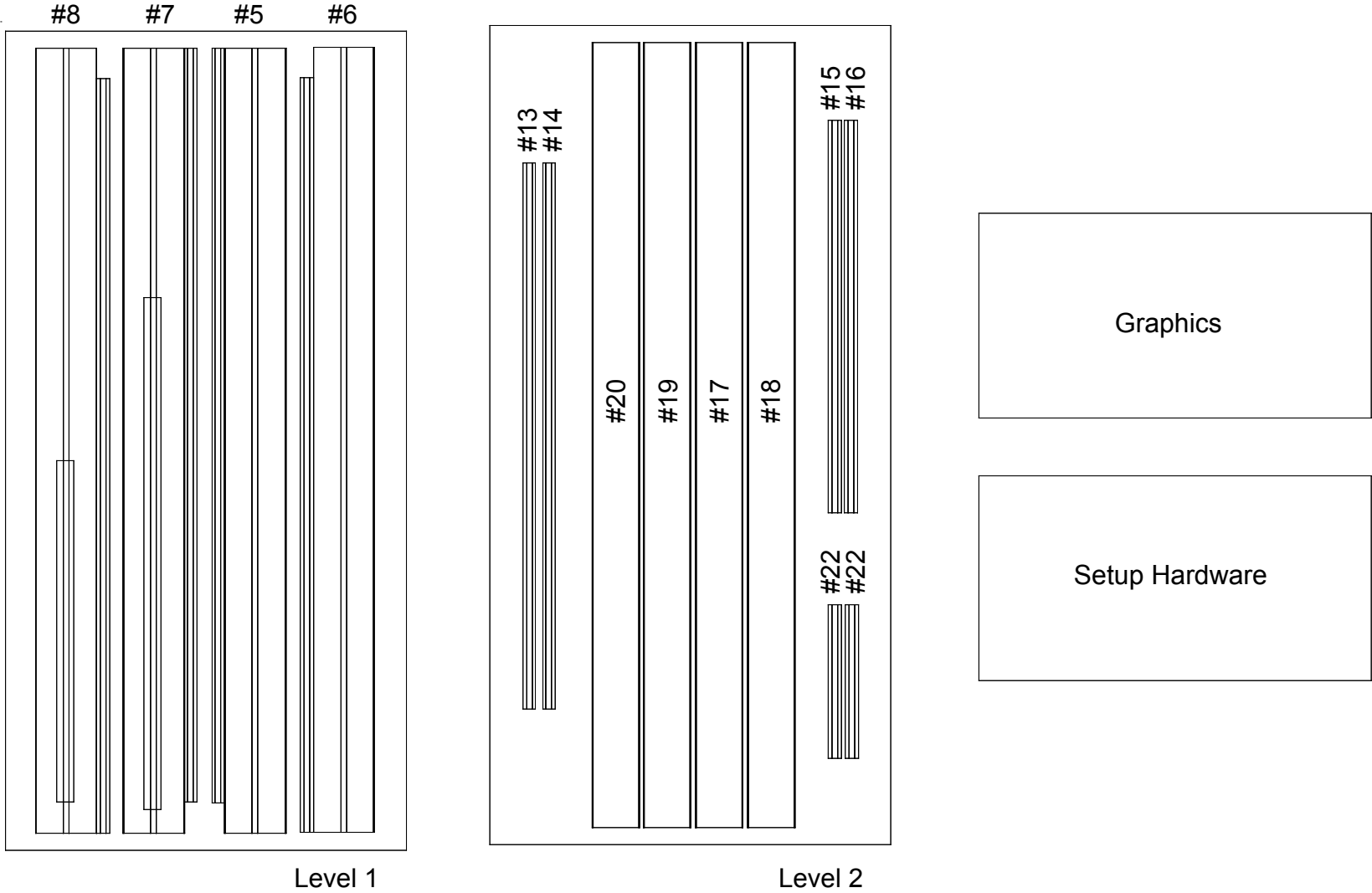

WHEN DISASSEMBLING ALUMINUM EXTRUSION, TIGHTEN ALL SETSCREWS AND LOCKS TO PREVENT LOSS DURING SHIPPING

Top View of Each Level

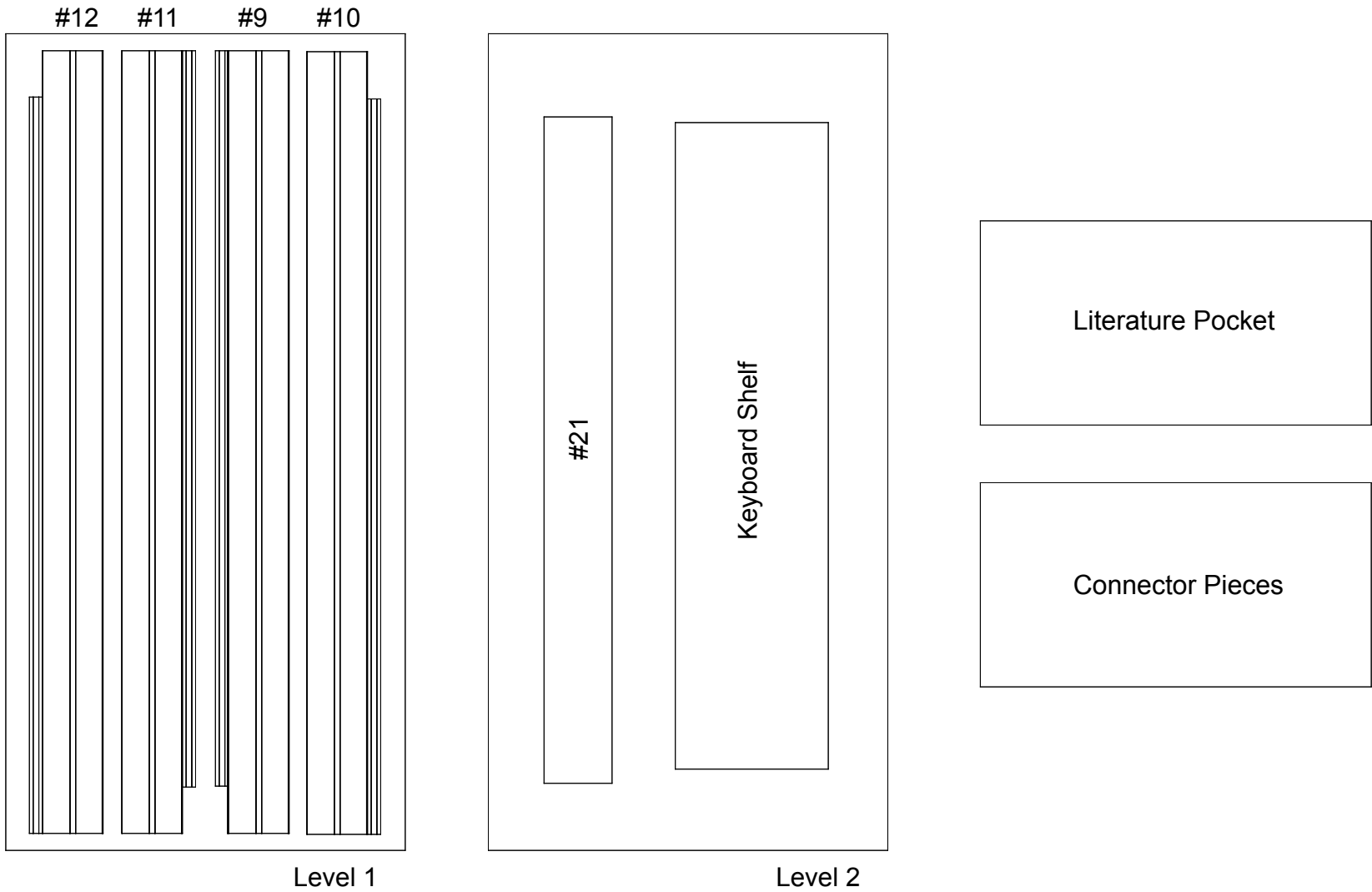

WHEN DISASSEMBLING ALUMINUM EXTRUSION, TIGHTEN ALL SETSCREWS AND LOCKS TO PREVENT LOSS DURING SHIPPING

Top View of Each Level

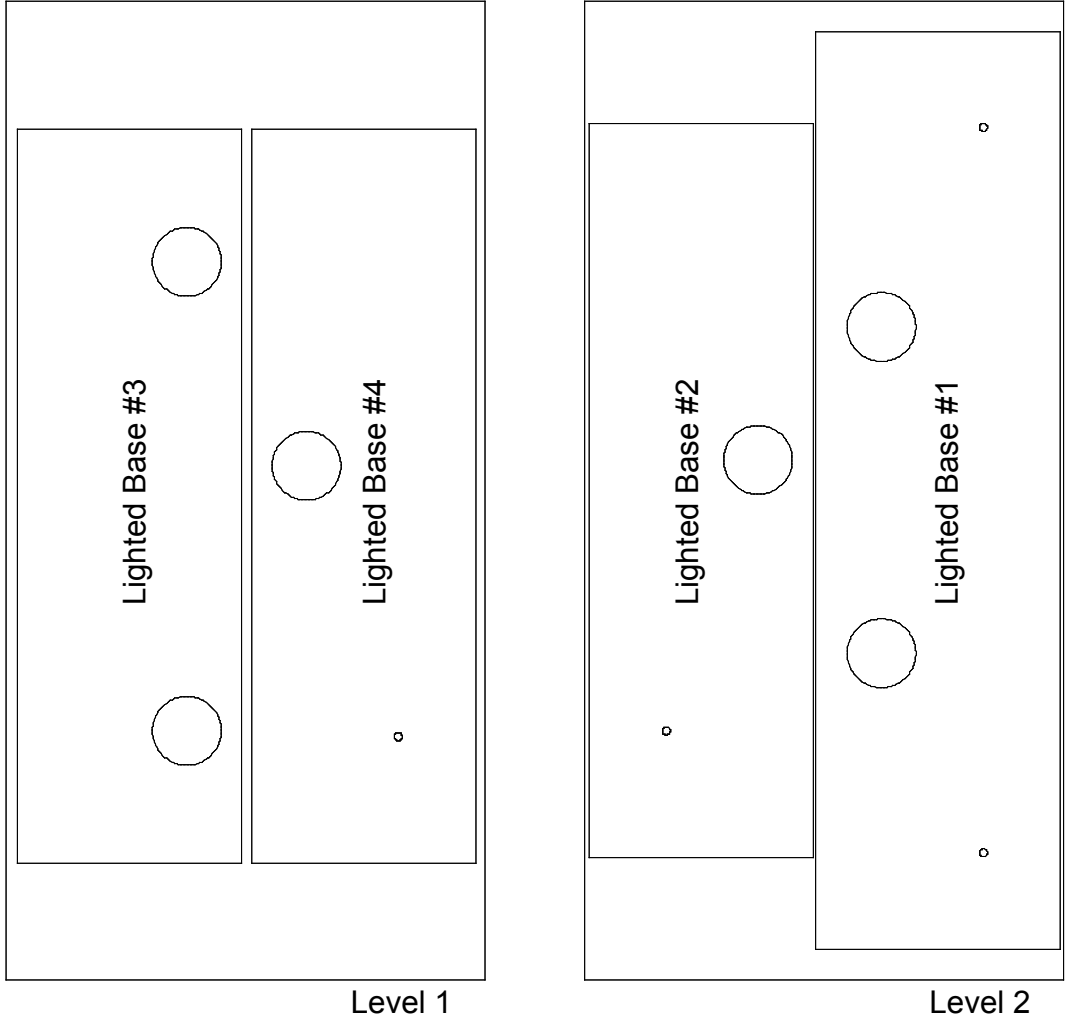

WHEN DISASSEMBLING ALUMINUM EXTRUSION, TIGHTEN ALL SETSCREWS AND LOCKS TO PREVENT LOSS DURING SHIPPING

Top View of Each Level

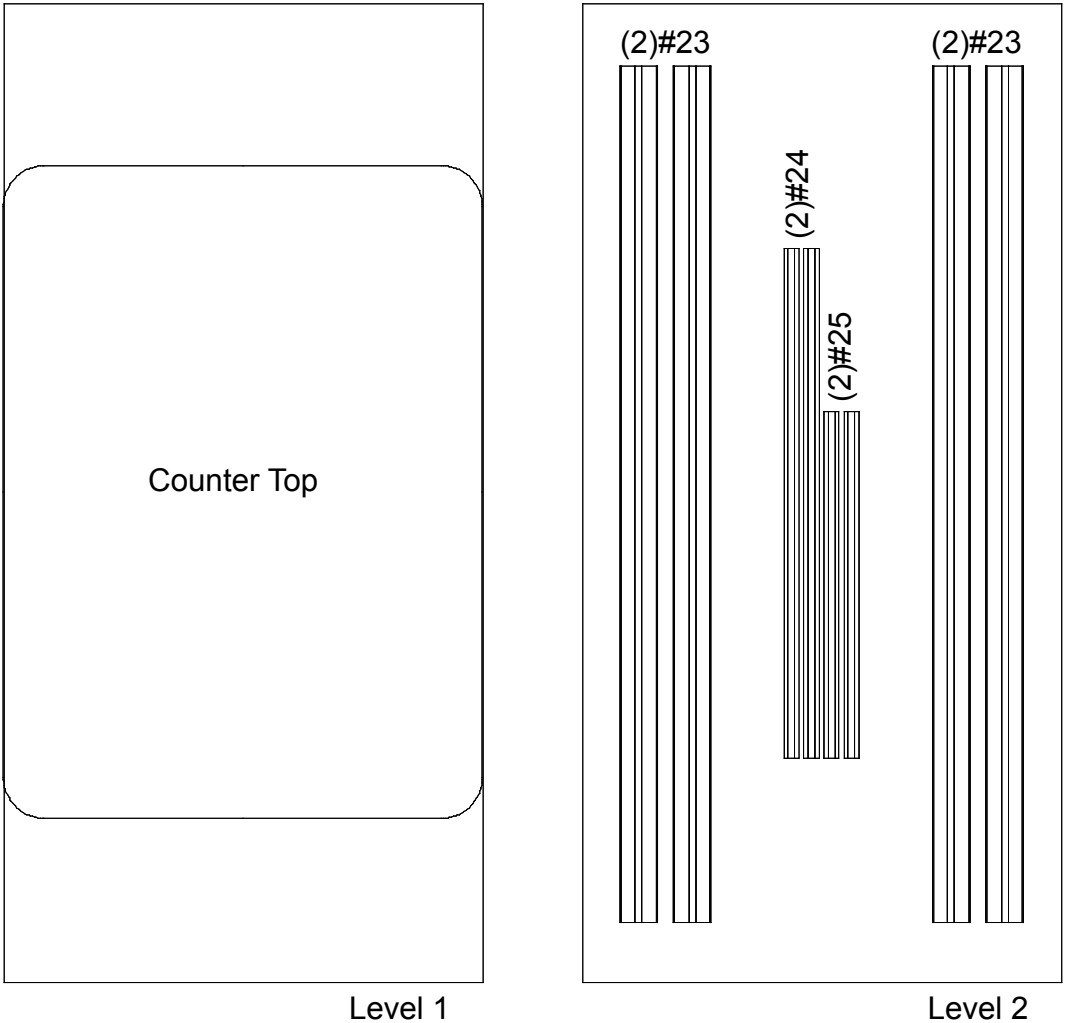

WHEN DISASSEMBLING ALUMINUM EXTRUSION, TIGHTEN ALL SETSCREWS AND LOCKS TO PREVENT LOSS DURING SHIPPING