

WHEN DISASSEMBLING ALUMINUM EXTRUSION, TIGHTEN ALL SETSCREWS AND LOCKS TO PREVENT LOSS DURING SHIPPING

# visionary™ DESIGNS

## Using Your Setup Instructions

The Visionary Designs Setup Instructions are created specifically for your configuration. They are laid out sequentially, including an exploded view of the entire display, and then a logical series of detailed steps to assemble the main structure and components. We encourage you to study the instructions **before** attempting to assemble your exhibit.

Each page reminds you to tighten the setscrews after disassembling your exhibit to prevent loss of the locks and setscrews (see below in RED). This is **VERY IMPORTANT**.

## Cleaning and Packing Your Display

- 1) Use care when cleaning aluminum extrusion or acrylic inserts. Use only non-abrasive cleaners.
- 2) When cleaning laminate inserts or countertops, use mild cleansers and a soft material such as cotton.
- 3) Keep all display components away from extreme heat and long exposure to sunlight to avoid warping and fading.
- 4) Retain all packing material. It will make re-packing much easier and will reduce the likelihood of shipping damage.



**The Tool**

Most Visionary Designs exhibits can be assembled with the supplied Hex Key Tool. Occasionally, a flat head screwdriver may be required.



**Typical Connection**

Most horizontal extrusion connections have a patented expandable lock. This lock inserts into the groove of an opposing extrusion. Tightening the lock with the Hex Key Tool expands the lock and creates a strong positive connection.



**Typical Connection (cont'd)**

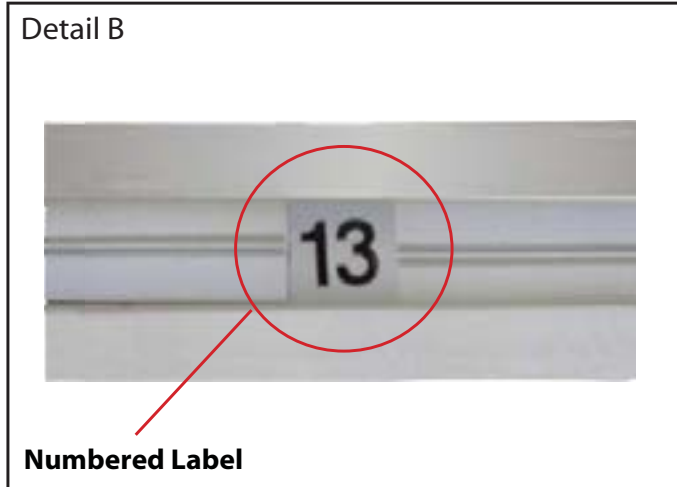

**Numbered Label**

Each extrusion contains a numbered label which corresponds with setup instructions. The label is located within a groove of the extrusion (when possible). With Visionary Designs the labels contain Black numbers unless otherwise specified.



**Horizontal Inline Connection** (remove only one setscrew)

Remove only (1) setscrew when disassembling. Replace setscrew in extrusion after assembling it. Before packing, replace setscrew in extrusion to avoid losing it.

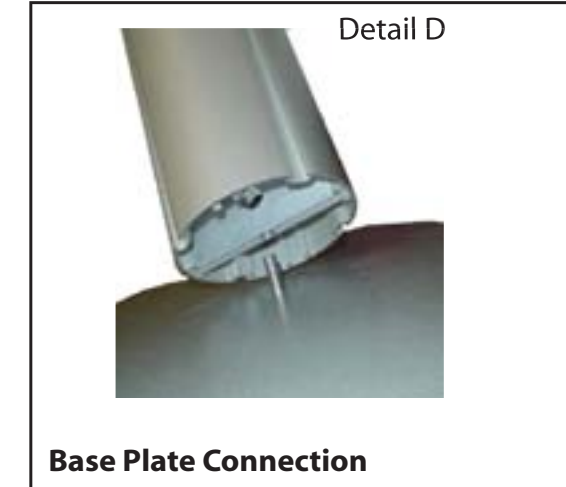

**Base Plate Connection**

Attach base plate to round or square vertical extrusion using the bolt provided. Be careful not to strip the threads.

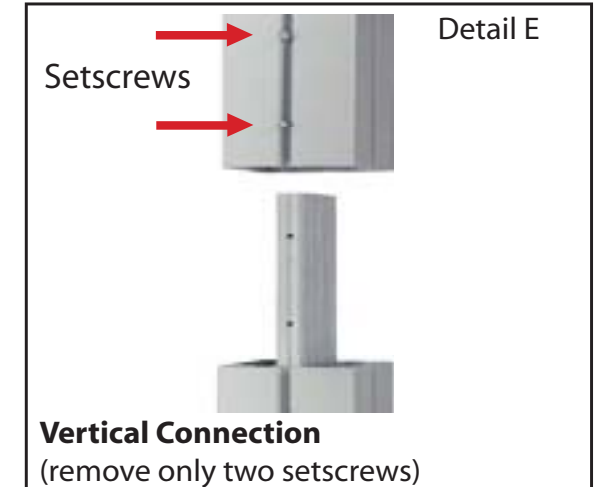

**Vertical Connection**  
(remove only two setscrews)

When vertical extrusions are packed in portable cases rather than crates or tubs, they must be broken down into smaller sections which then require assembly.

Remove only (2) setscrews when disassembling. Replace setscrews in extrusion after assembling it. Before packing, replace setscrews in extrusion to avoid losing them.

**WHEN DISASSEMBLING ALUMINUM EXTRUSION, TIGHTEN ALL SETSCREWS AND LOCKS TO PREVENT LOSS DURING SHIPPING**

866.652.2100

Item	Qty.	Description
1	4	Oval Base Plate
2	1	78"h Round Vertical Extrusion
3	1	78"h Square Vertical Extrusion
4	1	78"h Square Vertical Extrusion
5	1	84"h Round Vertical Extrusion
6	2	65.5"w Lower Horizontal Extrusion
7	1	76"w Lower Horizontal Extrusion
8	2	65.5"w Upper Horizontal Extrusion
9	1	76"w Upper Horizontal Erusion

- Steps:
- 1) Attach oval base plates [1] to verticals as shown.
  - 2) Attach lower and upper horizontal extrusions and assemblies between vertical as shown. Note: Horizontal extrusions attach between S10, or between S10 and S12. S10 and S12 are attached to vertical extrusions [2 thru 5] as shown.
  - 3) Attach canopy connector pieces to atop vertical extrusions [2 & 5].
  - 4) Apply graphic to FRONT of assembled backwall.

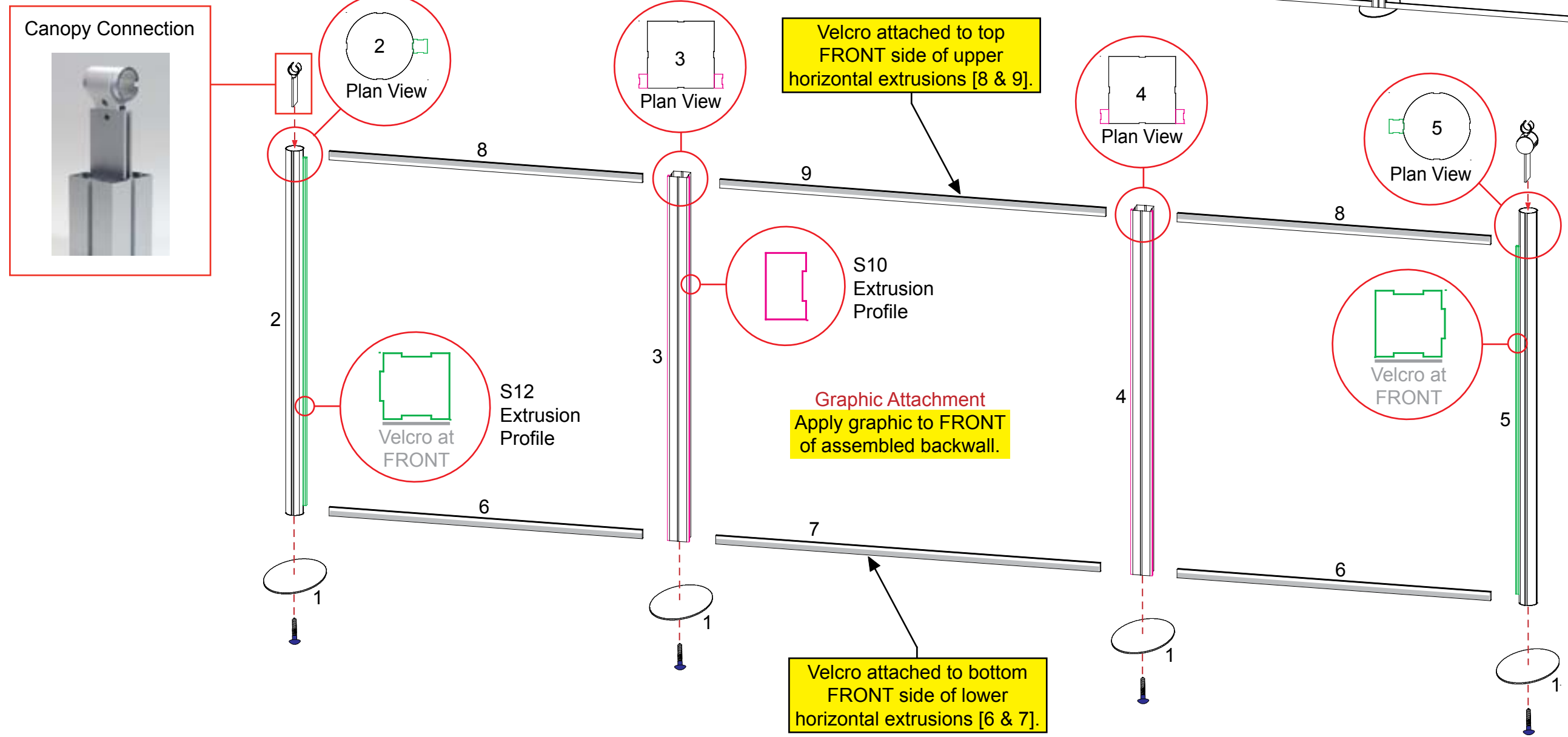
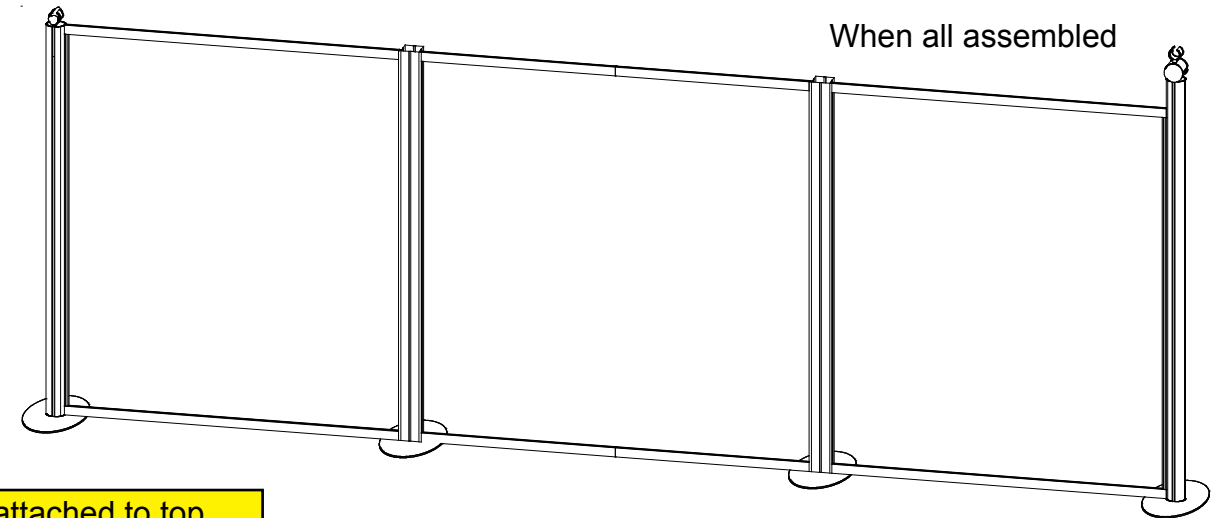

**WHEN DISASSEMBLING ALUMINUM EXTRUSION, TIGHTEN ALL SETSCREWS AND LOCKS TO PREVENT LOSS DURING SHIPPING**

866.652.2100

Item	Qty.	Description
10	1	79.3189" w Canopy Curved Round Extrusion
11	1	79.3189" w Canopy Curved Round Extrusion
12	1	79.3189" w Canopy Curved Round Extrusion
13	1	79.3189" w Canopy Curved Round Extrusion
14	1	79.3189" w Canopy Curved Round Extrusion
15	1	79.3189" w Canopy Curved Round Extrusion
16	1	5.245" w Canopy Round Extrusion
17	1	7.499" w Canopy Extrusion
18	1	11.304" w Canopy Extrusion
19	1	15.116" w Canopy Extrusion
20	1	20.529" w Canopy Round Extrusion

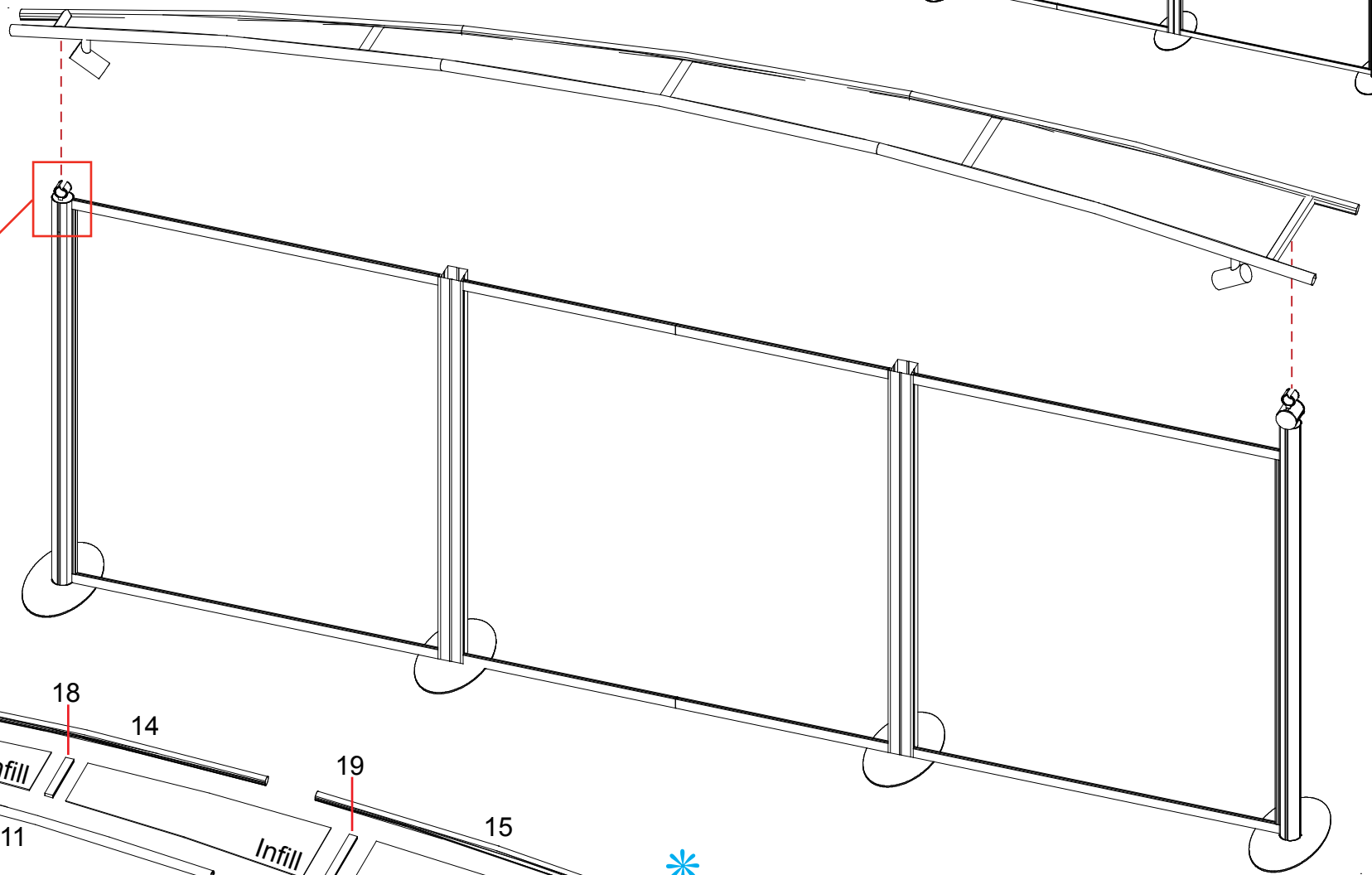
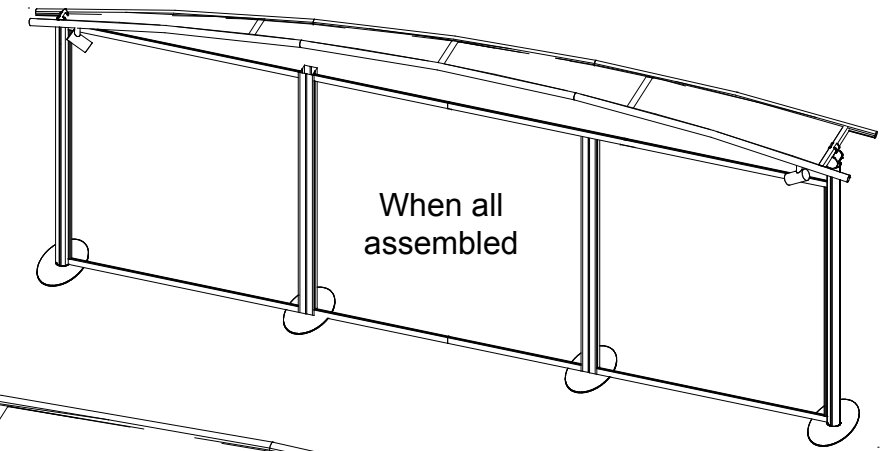

Attach extrusion #20 over PR55 Connection and tighten setscrews.

\* Repeat for extrusion #16.

Canopy Connection Piece

\* 20 15

\* Canopy Extrusion Connections Examples

16 13 17 18 14 19 15 12 11 10

Light

Infill

Light

\* \*

- Steps:
- 1) Attach all canopy round extrusions [10 thru 20] together.  
Note: Place Infill into groove between canopy extrusions.
  - 2) Attach light to canopy extrusions [10 & 12].
  - 3) Attach assembled canopy atop *Canopy Connection Piece*.

**WHEN DISASSEMBLING ALUMINUM EXTRUSION, TIGHTEN ALL SETSCREWS AND LOCKS TO PREVENT LOSS DURING SHIPPING**

Part Number	Qty for Step	Description
21	1	18"D Round Base Plate
22	1	80"h Round Vertical Extrusion
23	1	36"h Round Vertical Extrusion

Steps

- 1) Attach vertical extrusions [22 and 23] to base plate [21] as shown.
- 2) Attach tapered plex wing to front of vertical extrusion [23] using standoff caps and round sign to vertical extrusion [22].
- 3) Place and attach counter atop vertical extrusion [23].

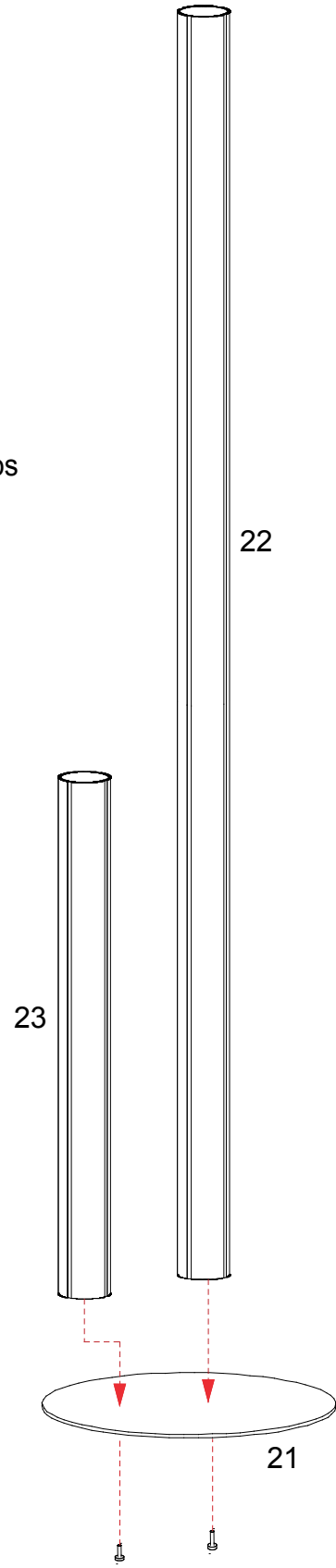

**Sign Attachment**

stand off barrel

Slide stand off barrels to groove of backwall extrusion

Secure Sign to stand off barrels using stand off caps

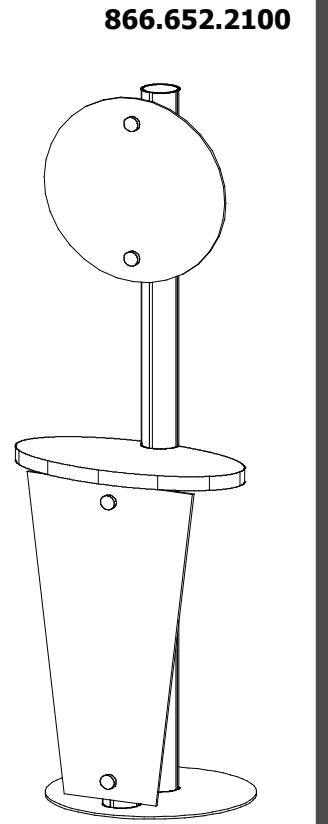
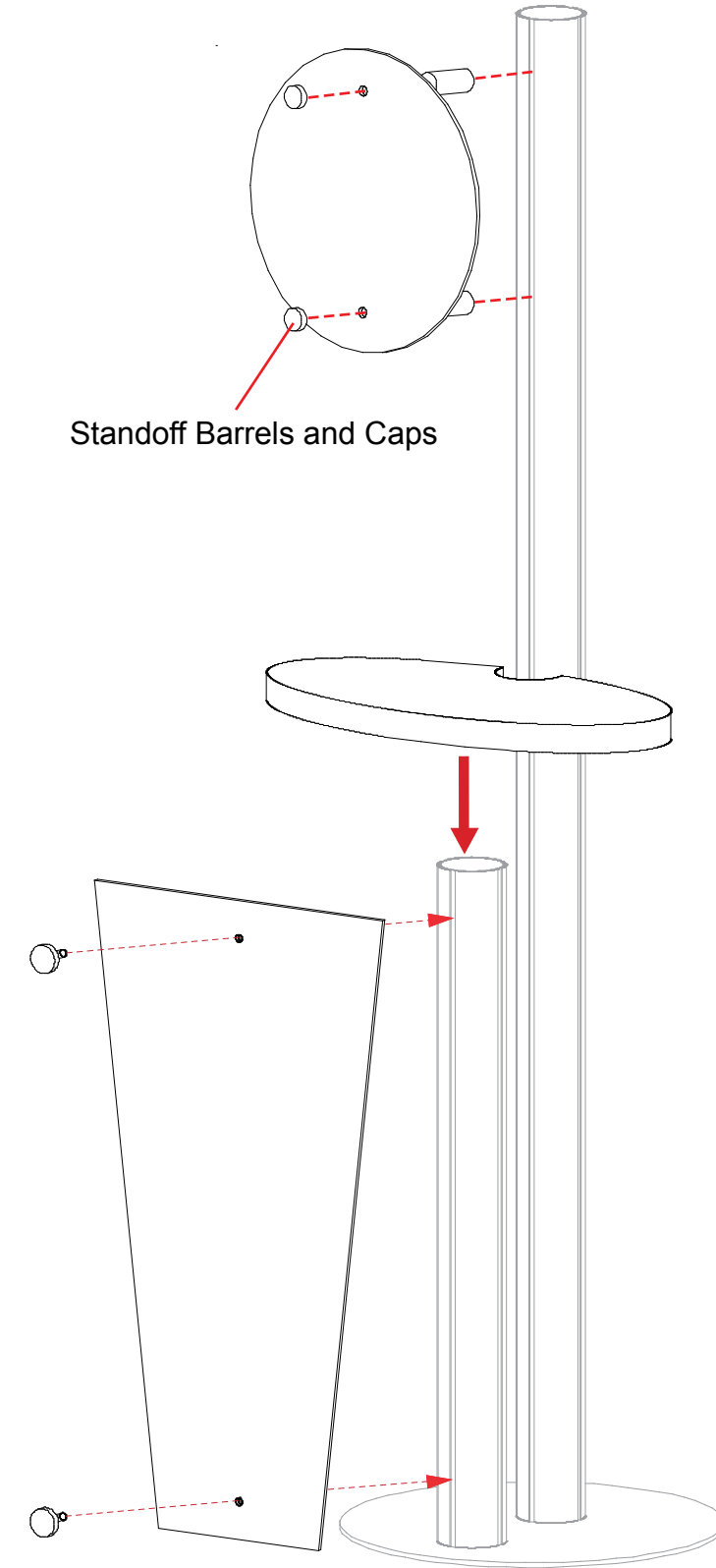

866.652.2100

**WHEN DISASSEMBLING ALUMINUM EXTRUSION, TIGHTEN ALL SETSCREWS AND LOCKS TO PREVENT LOSS DURING SHIPPING**

866.652.2100

Item	Qty.	Description
24	2	38"h Square Vertical Extrusion
25	2	38"h Round Vertical Extrusion
26	1	38"h Angled Vertical Extrusion w/ Door Stopper
27	1	38"h Angled Vertical Extrusion w/ Door Hinges
28	1	27.739" Curved Horizontal Extrusion
29	2	12.5"w Horizontal Extrusion
30	1	28"w Horizontal Extrusion
31	1	27.739" Curved Horizontal Extrusion
32	2	12.5"w Horizontal Extrusion
33	1	28"w Horizontal Extrusion

Steps:

- 1) Attach angled vertical extrusions [26 & 27] to verticals [25]. \*\* Refer to *V10 Pressure Screw Attachment* detail.
- 2) Attach upper and lower horizontal extrusions [29 & 32] between verticals [25 & 24]. Note: Place infills between horizontal and vertical extrusions as shown.
- 3) Attach upper and lower horizontal extrusions [30 & 33] between verticals [24]. Note: Place infill between horizontal and vertical extrusions as shown.
- 4) Attach upper and lower horizontal curved extrusions [28 & 31] between vertical extrusions [26 & 27]. Note: Attach door between horizontal and vertical extrusions as shown. Refer to *Door Attachment* detail.
- 5) Velcro attach shelf supports to inside of pedestal.
- 6) Place internal shelf atop shelf supports.
- 7) Place counter top atop assembled pedestal.

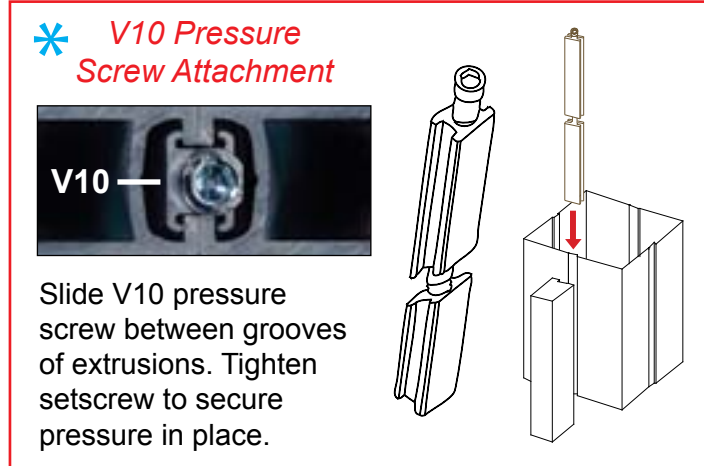
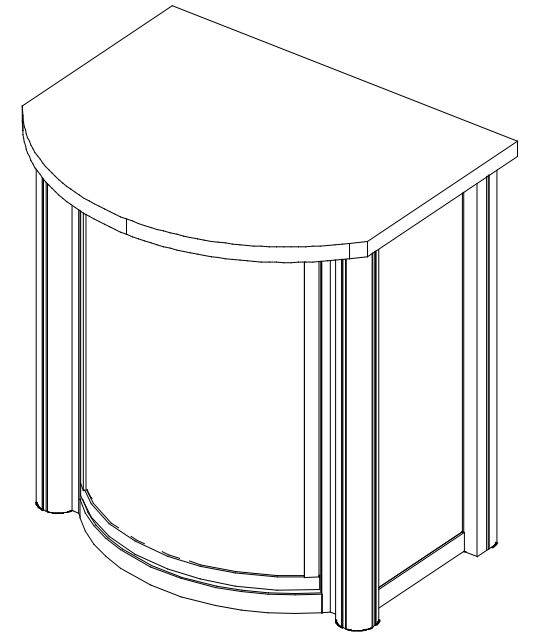

\*\*Note: Keep vertical extrusions [25 & 26] and [25 & 27] assembled when shipping.

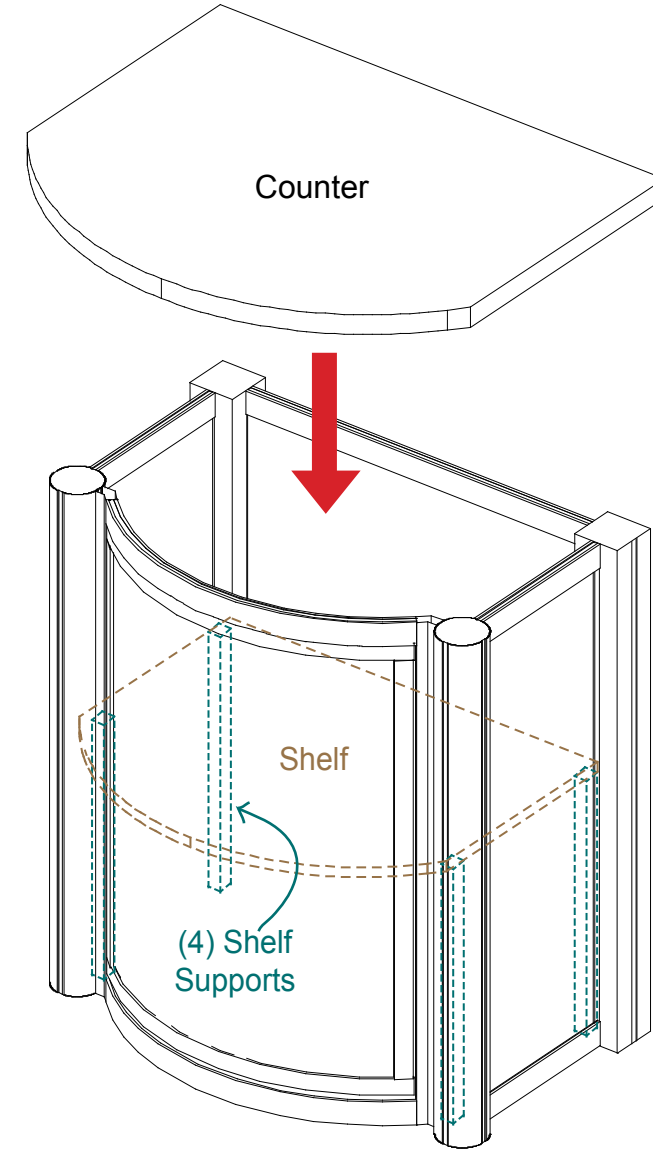
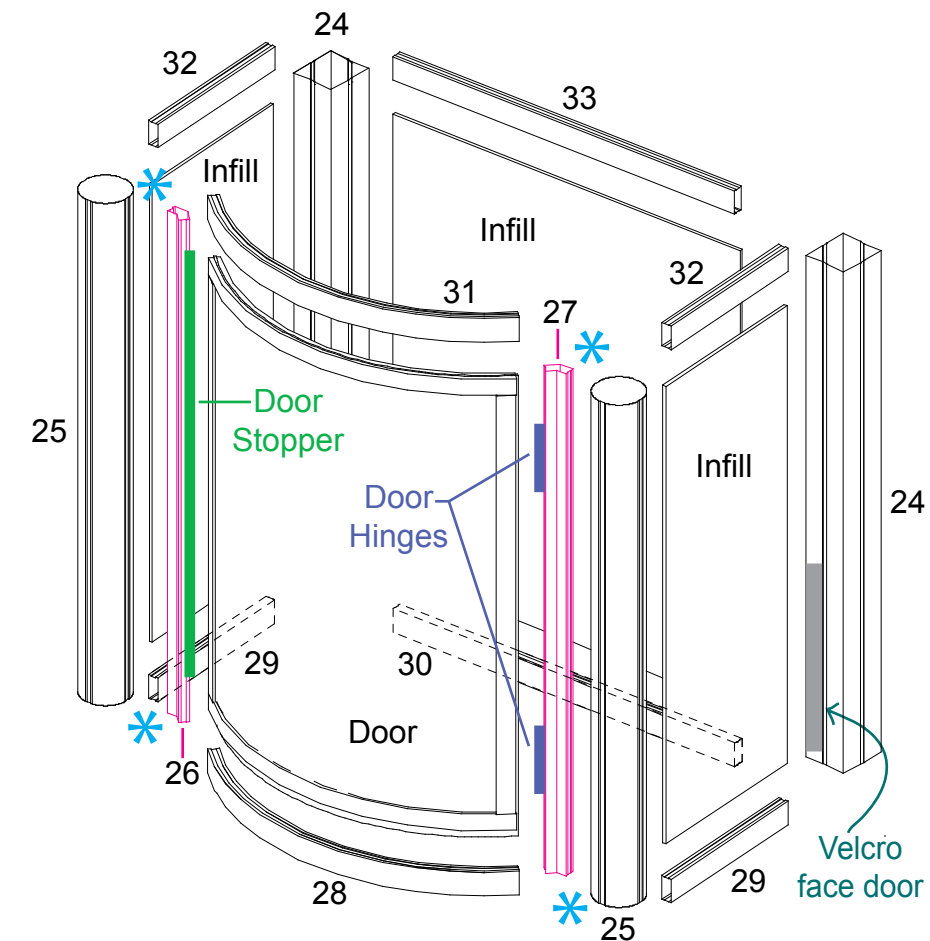
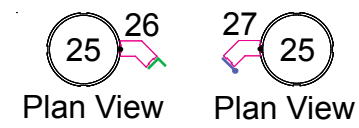

WHEN DISASSEMBLING ALUMINUM EXTRUSION, TIGHTEN ALL SETSCREWS AND LOCKS TO PREVENT LOSS DURING SHIPPING

866.652.2100

Item	Qty.	Description
25	2	38" h Round Vertical Extrusion
26	1	38" h Angled Vertical Extrusion w/ Door Stopper
27	1	38" h Angled Vertical Extrusion w/ Door Hinges
28	1	27.739" Curved Horizontal Extrusion
29	2	12.5" w Horizontal Extrusion
30	1	28" w Horizontal Extrusion
31	1	27.739" Curved Horizontal Extrusion
32	2	12.5" w Horizontal Extrusion
33	2	28" w Horizontal Extrusion
34	2	38" h Square Vertical Extrusion

Steps:

- 1) Attach angled vertical extrusions [26 & 27] to verticals [25]. \*\* Refer to *V10 Pressure Screw Attachment* detail.
- 2) Attach upper and lower horizontal extrusions [29 & 32] between verticals [25 & 34]. Note: Place infills between horizontal and vertical extrusions as shown.
- 3) Attach upper and lower horizontal extrusions [30 & 33] between verticals [34]. Note: Place infill between horizontal and vertical extrusions as shown.
- 4) Attach upper and lower horizontal curved extrusions [28 & 31] between vertical extrusions [26 & 27]. Note: Attach door between horizontal and vertical extrusions as shown. Refer to *Door Attachment* detail.

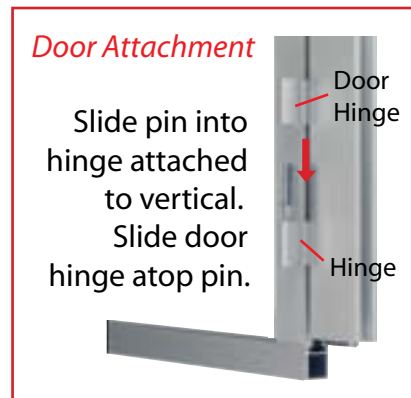
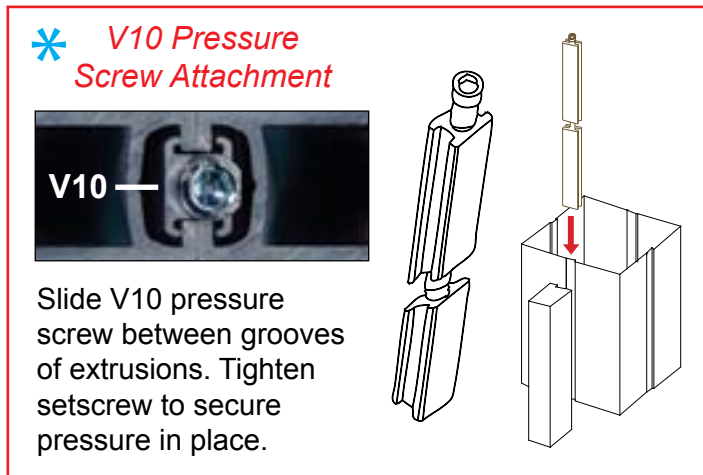

\*\*Note: Keep vertical extrusions [25 & 26] and [25 & 27] assembled when shipping.

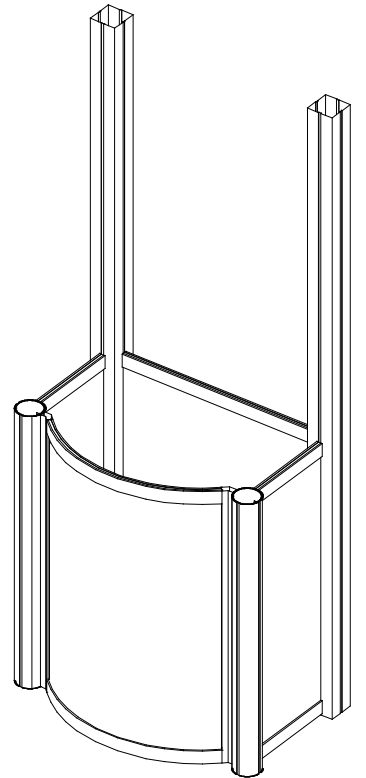
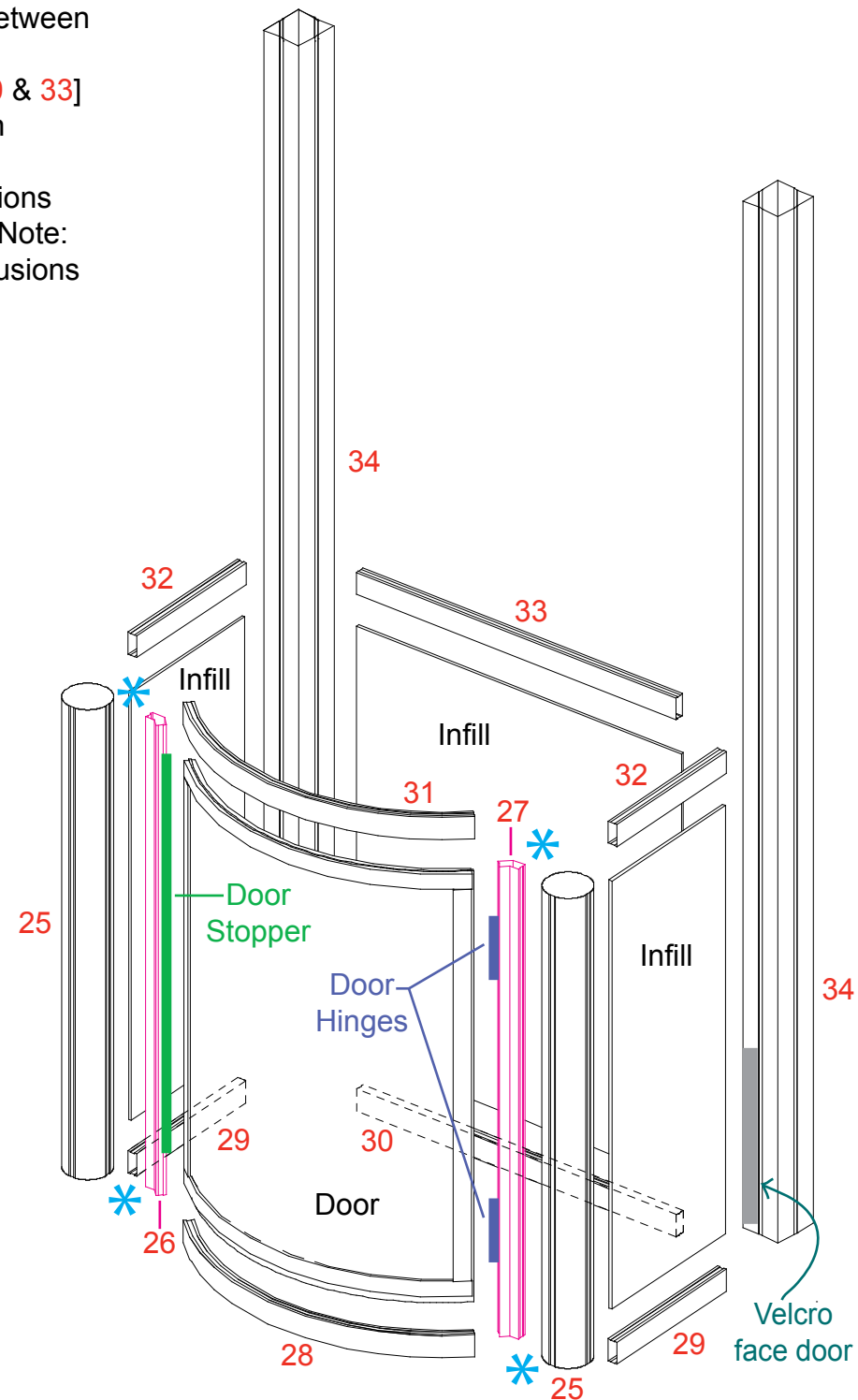

WHEN DISASSEMBLING ALUMINUM EXTRUSION, TIGHTEN ALL SETSCREWS AND LOCKS TO PREVENT LOSS DURING SHIPPING

866.652.2100

Item	Qty.	Description
35	1	28" w Horizontal Extrusion

- Steps:
- 1) Velcro attach shelf supports to inside of pedestal.
  - 2) Place internal shelf atop shelf supports.
  - 3) Place counter top atop assembled pedestal.
  - 4) Attach horizontal extrusion [35] between verticals [34].
  - 5) Attach monitor mount to verticals [34]. Refer to *Monitor Mount Attachment* detail.

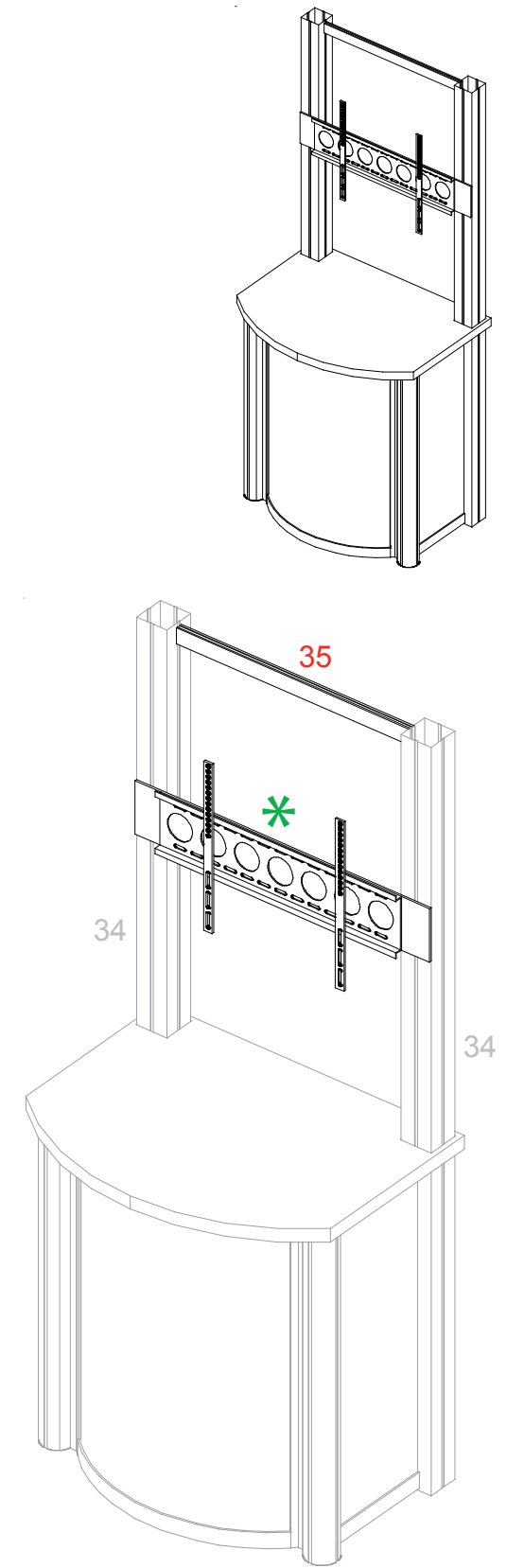
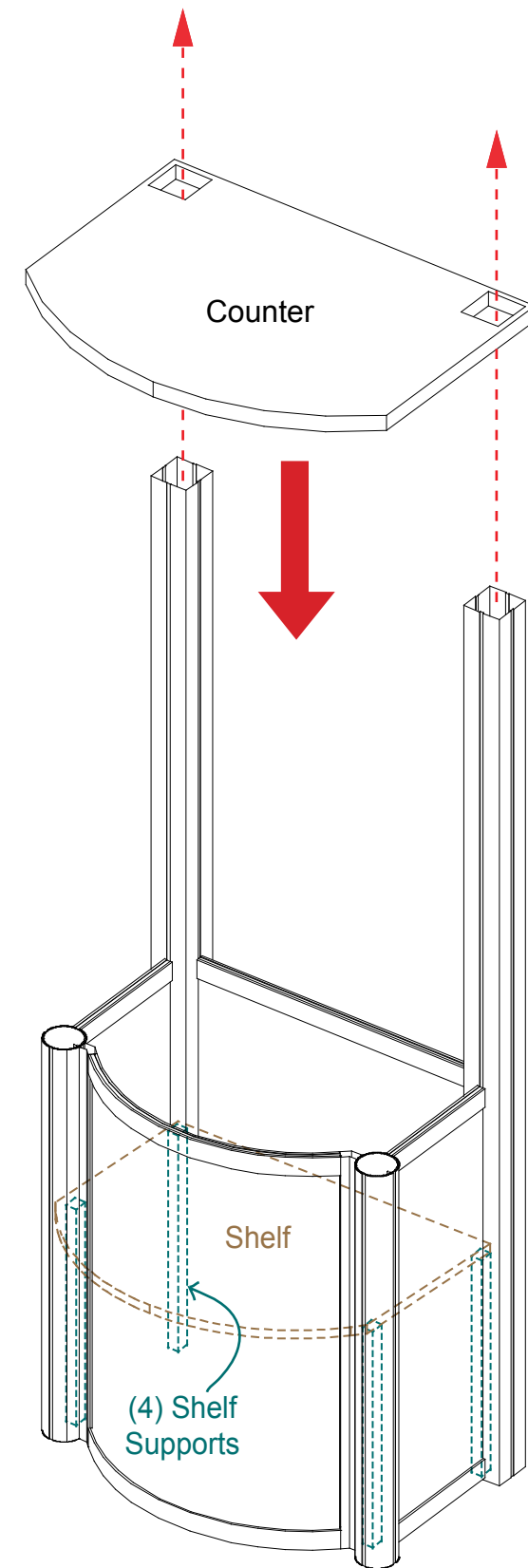
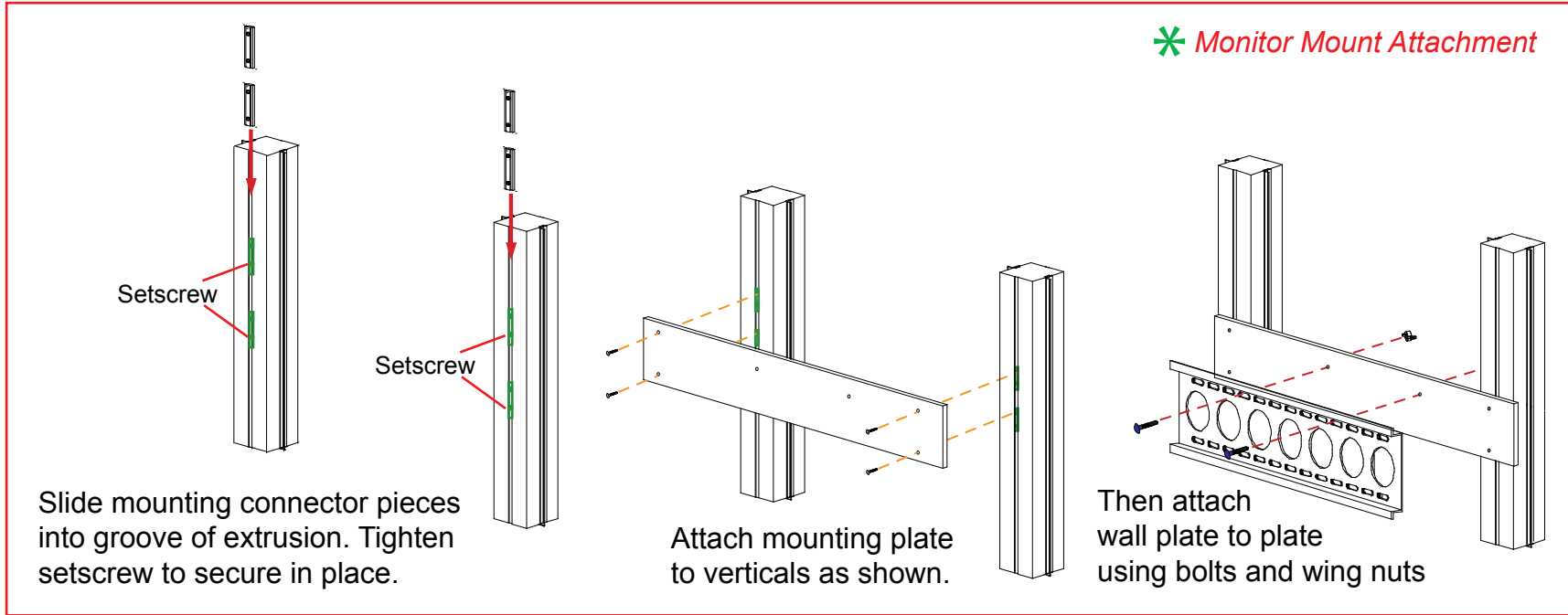

WHEN DISASSEMBLING ALUMINUM EXTRUSION, TIGHTEN ALL SETSCREWS AND LOCKS TO PREVENT LOSS DURING SHIPPING

Top View of Each Level

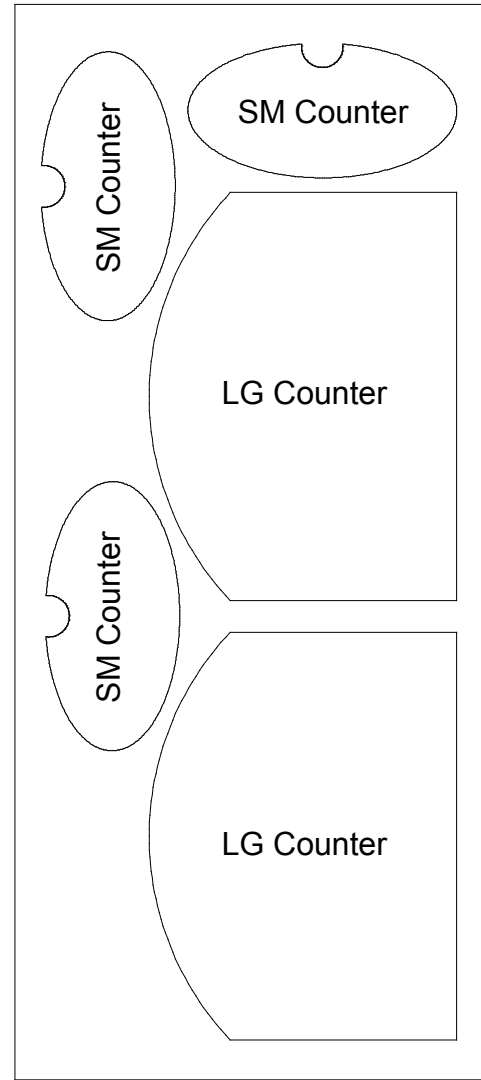

Level 1

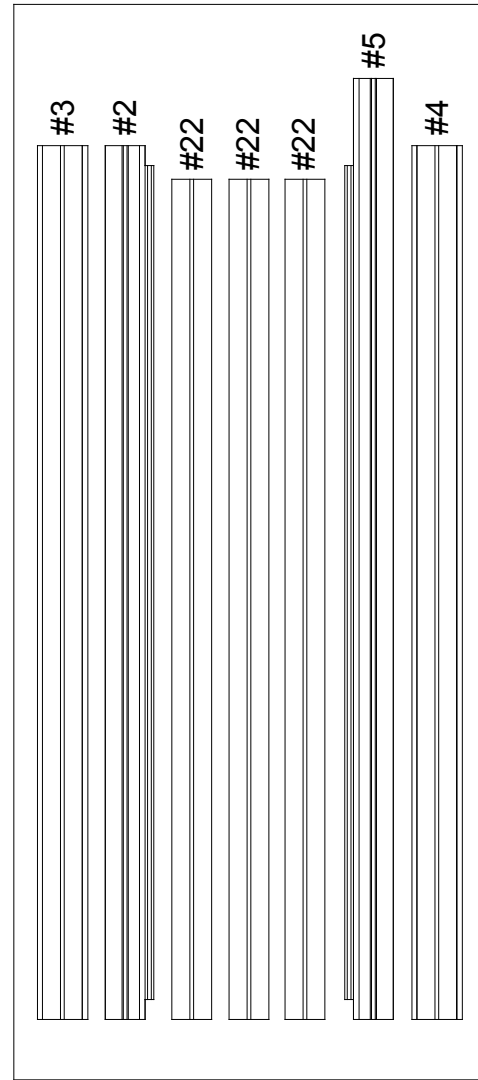

Level 2

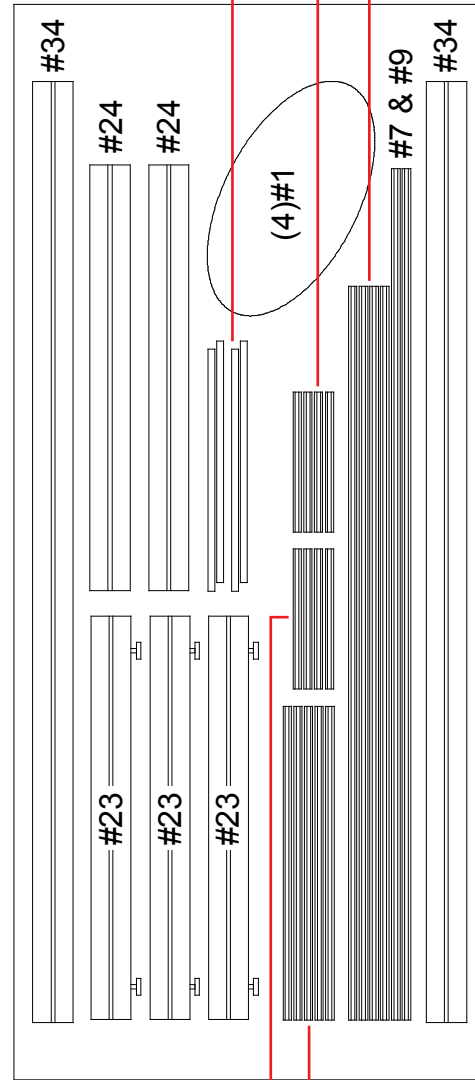

Level 3

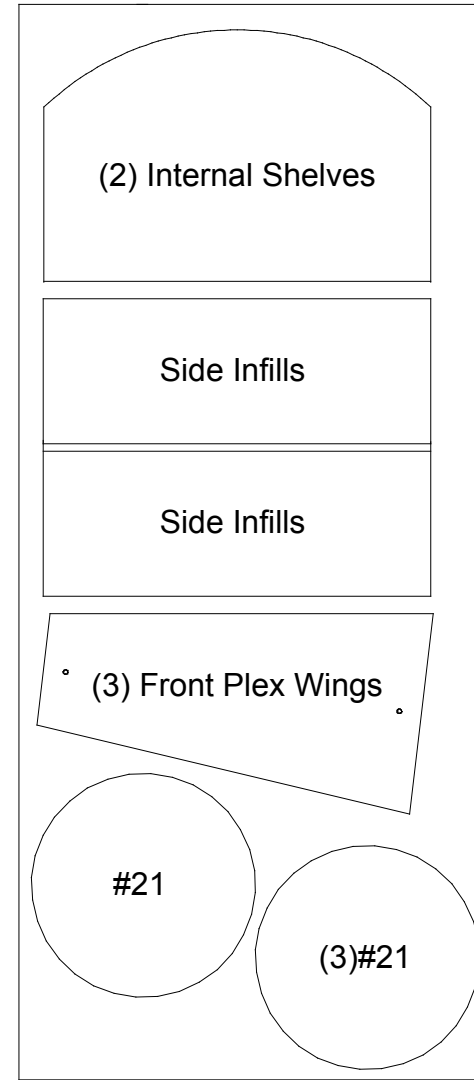

Level 4

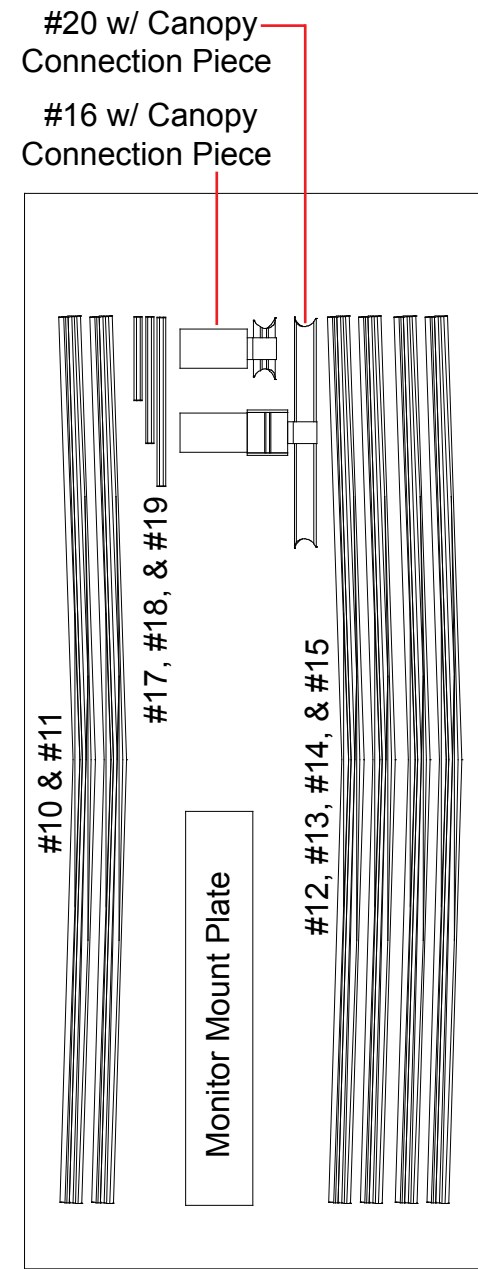

Level 5

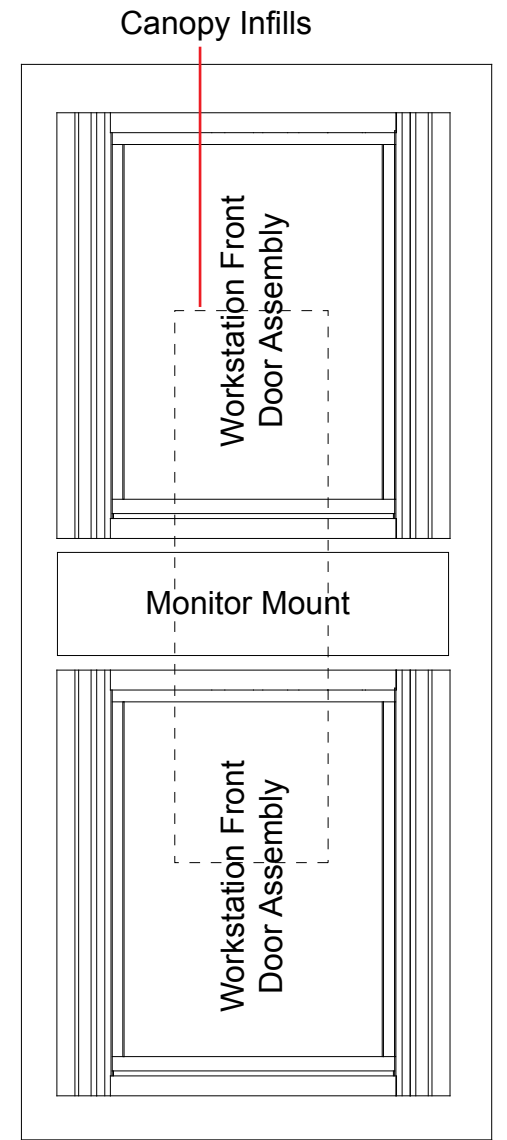

Level 6

WHEN DISASSEMBLING ALUMINUM EXTRUSION, TIGHTEN ALL SETSCREWS AND LOCKS TO PREVENT LOSS DURING SHIPPING



Level 1



Level 2



Level 3

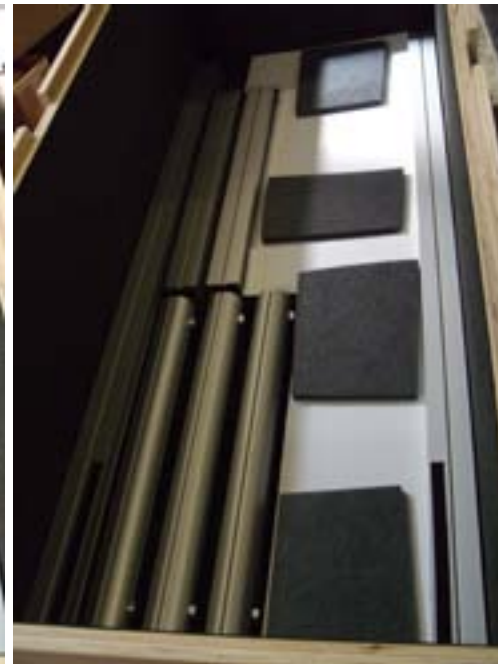

Level 3 w/ Slip Sheet



Level 4



Level 5



Level 6



Level 6



Level 6



Level 6

WHEN DISASSEMBLING ALUMINUM EXTRUSION, TIGHTEN ALL SETSCREWS AND LOCKS TO PREVENT LOSS DURING SHIPPING