

WHEN DISASSEMBLING ALUMINUM EXTRUSION, TIGHTEN ALL SETSCREWS AND LOCKS TO PREVENT LOSS DURING SHIPPING

visionary™ IDESIGNS

Using Your Setup Instructions

The Visionary Designs Setup Instructions are created specifically for your configuration. They are laid out sequentially, including an exploded view of the entire display, and then a logical series of detailed steps to assemble the main structure and components. We encourage you to study the instructions **before** attempting to assemble your exhibit.

Each page reminds you to tighten the setscrews after disassembling your exhibit to prevent loss of the locks and setscrews (see below in RED). This is **VERY IMPORTANT**.

Cleaning and Packing Your Display

- 1) Use care when cleaning aluminum extrusion or acrylic inserts. Use only non-abrasive cleaners.
- 2) When cleaning laminate inserts or countertops, use mild cleansers and a soft material such as cotton.
- 3) Keep all display components away from extreme heat and long exposure to sunlight to avoid warping and fading.
- 4) Retain all packing material. It will make re-packing much easier and will reduce the likelihood of shipping damage.



The Tool

Most Visionary Designs exhibits can be assembled with the supplied Hex Key Tool. Occasionally, a flat head screwdriver may be required.



Typical Connection

Most horizontal extrusion connections have a patented expandable lock. This lock inserts into the groove of an opposing extrusion. Tightening the lock with the Hex Key Tool expands the lock and creates a strong positive connection.



Typical Connection (cont'd)

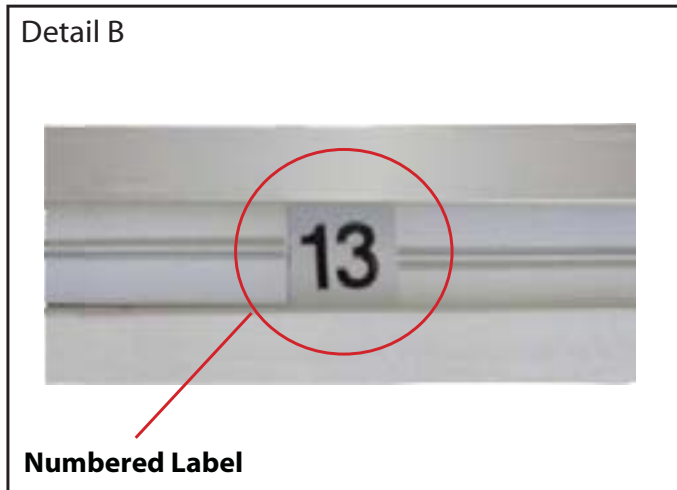

Detail B

Numbered Label

Each extrusion contains a numbered label which corresponds with setup instructions. The label is located within a groove of the extrusion (when possible). With Visionary Designs the labels contain Black numbers unless otherwise specified.



Detail C

Horizontal Inline Connection (remove only one setscrew)

Remove only (1) setscrew when disassembling. Replace setscrew in extrusion after assembling it. Before packing, replace setscrew in extrusion to avoid losing it.

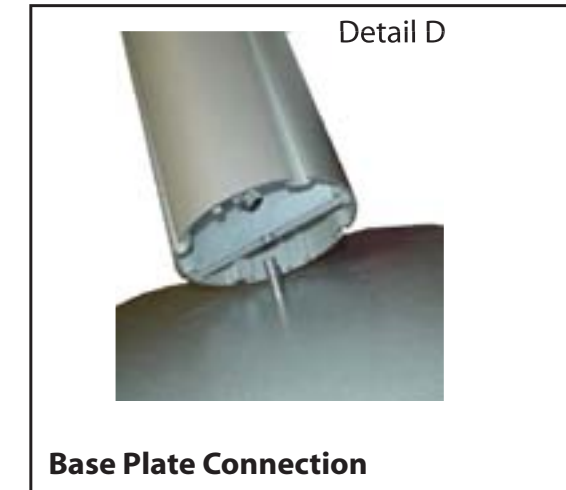

Detail D

Base Plate Connection

Attach base plate to round or square vertical extrusion using the bolt provided. Be careful not to strip the threads.

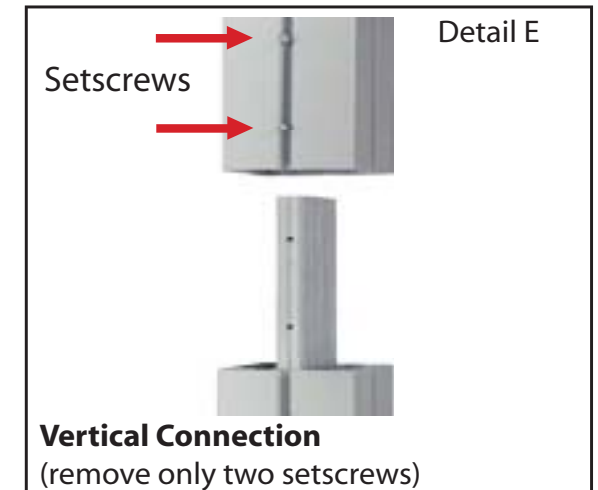

Detail E

Vertical Connection
(remove only two setscrews)

When vertical extrusions are packed in portable cases rather than crates or tubs, they must be broken down into smaller sections which then require assembly.

Remove only (2) setscrews when disassembling. Replace setscrews in extrusion after assembling it. Before packing, replace setscrews in extrusion to avoid losing them.

WHEN DISASSEMBLING ALUMINUM EXTRUSION, TIGHTEN ALL SETSCREWS AND LOCKS TO PREVENT LOSS DURING SHIPPING

866.652.2100

Item	Qty.	Description	Item	Qty.	Description
1	3	Oval Base Plate	11	1	34" w Horizontal Extrusion
2	1	41.75" h Lower Square Vertical Extrusion	12	1	34" w Horizontal Extrusion
3	1	42" h Upper Square Vertical Extrusion w/ Canopy Attachment	13a/13b	2/2	41.75" Horizontal Extrusion
4	1	41.75" h Lower Square Vertical Extrusion	14	2	25" w Horizontal Extrusion
4A/4B	1/1	42" h Lower Square Vertical Extrusion	15	2	28" w Horizontal Extrusion
5	3	42" h Upper Square Vertical Extrusion w/ Canopy Attachment	16a/16b	1/1	26" w Horizontal Extrusion
6	1	41.75" h Lower Square Vertical Extrusion	16c/16d	1/1	26" w Horizontal Extrusion
7	1	42" h Upper Square Vertical Extrusion w/ Canopy Attachment			
8	2	42" h Lower Square Vertical Extrusion			
9	2	21.167" w Horizontal Extrusion			
10	2	21.167" w Horizontal Extrusion			

Steps:

- 1) Attach lower vertical extrusions [2, 4 and 6] to oval base plates [1].
- 2) Attach upper vertical extrusions [3, 5 and 7] atop lower vertical extrusions [2, 4, 4A, and 6].
- 3) Connect horizontal extrusions [13a to 13b, 16a to 16b and 16c to 16d] together.
- 4) Attach lower horizontal extrusions [9 and 11] between vertical extrusions [2/3, 8 and 4/5] as shown.
- 5) Place inserts and attach mid horizontal extrusions [10 and 12] between vertical extrusions [2/3, 8, and 4/5] and atop inserts.
- 6) Attach horizontal assembly [13a/13b] between vertical extrusions [2/3 and 4/5].
- 7) Attach horizontal extrusions [14, 15, 16a/16b, and 16c/16d] between vertical extrusions [4/5, 4a/5, and 6/7] as shown, placing insert between horizontal extrusions [15] as indicated.
- 8) Apply graphics to assembled backwall, see Attaching Graphic details.

Note: Attaching Graphics
Attach Backwall Graphics to Velcro on front

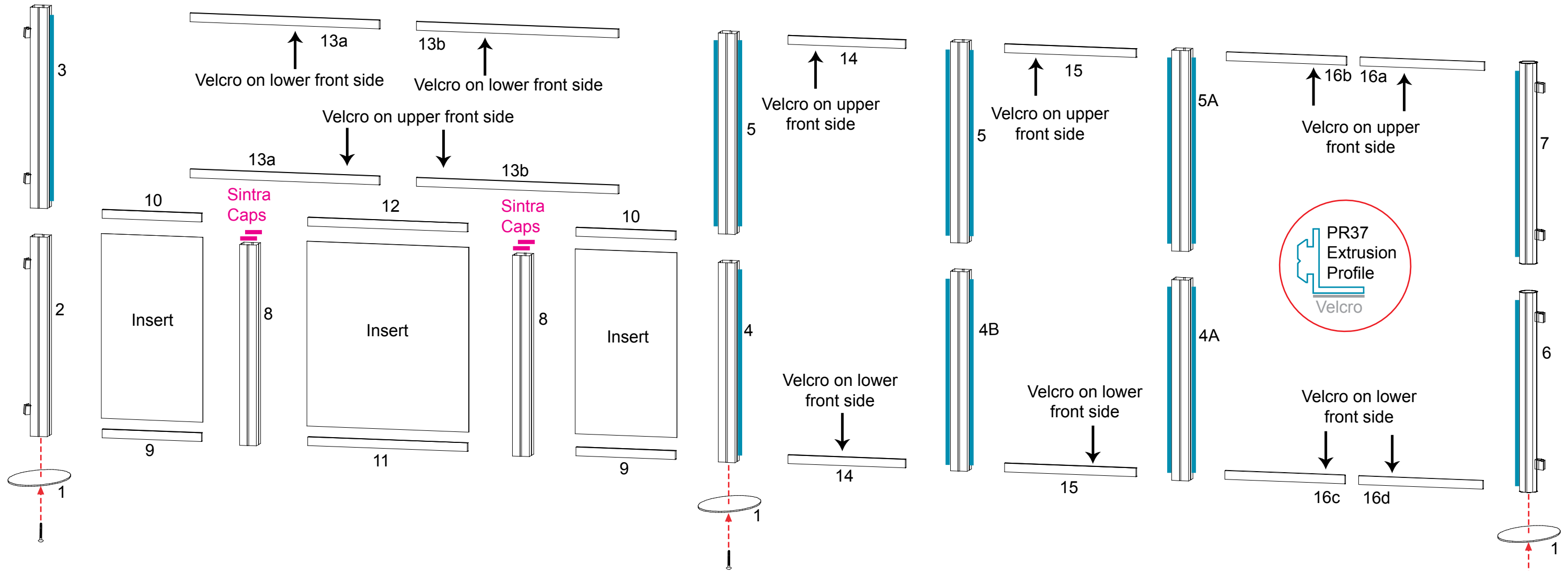

WHEN DISASSEMBLING ALUMINUM EXTRUSION, TIGHTEN ALL SETSCREWS AND LOCKS TO PREVENT LOSS DURING SHIPPING

866.652.2100

Item	Qty	Description
17	4	12.5"w Horizontal Extrusion
18	1	38"h Round Vertical Extrusion
18a	1	38"h Round Vertical Extrusion
18b	1	38"h 135° Vertical Extrusion
18c	1	38"h 135° Vertical Extrusion w/ Door Stop
18d	1	Vertical Extrusion w/ Door Hinge
19	2	Curved Horizontal Extrusion
4	4	Internal Shelf Support

Steps

- 1) Attach lower horizontal extrusions [17 and 19] between vertical extrusions as shown.
- 2) Place inserts and door where indicated.
- 3) Attach upper horizontal extrusions [17 and 19] between vertical extrusions as shown.
- 4) Insert internal shelf and set atop velcroed supports.
- 5) Place coner atop assembled pedestal.

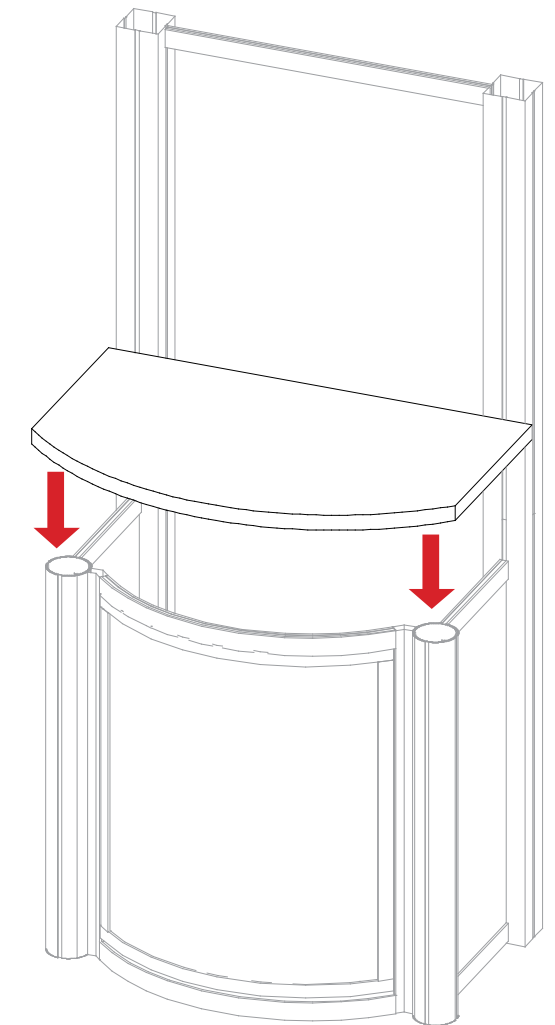
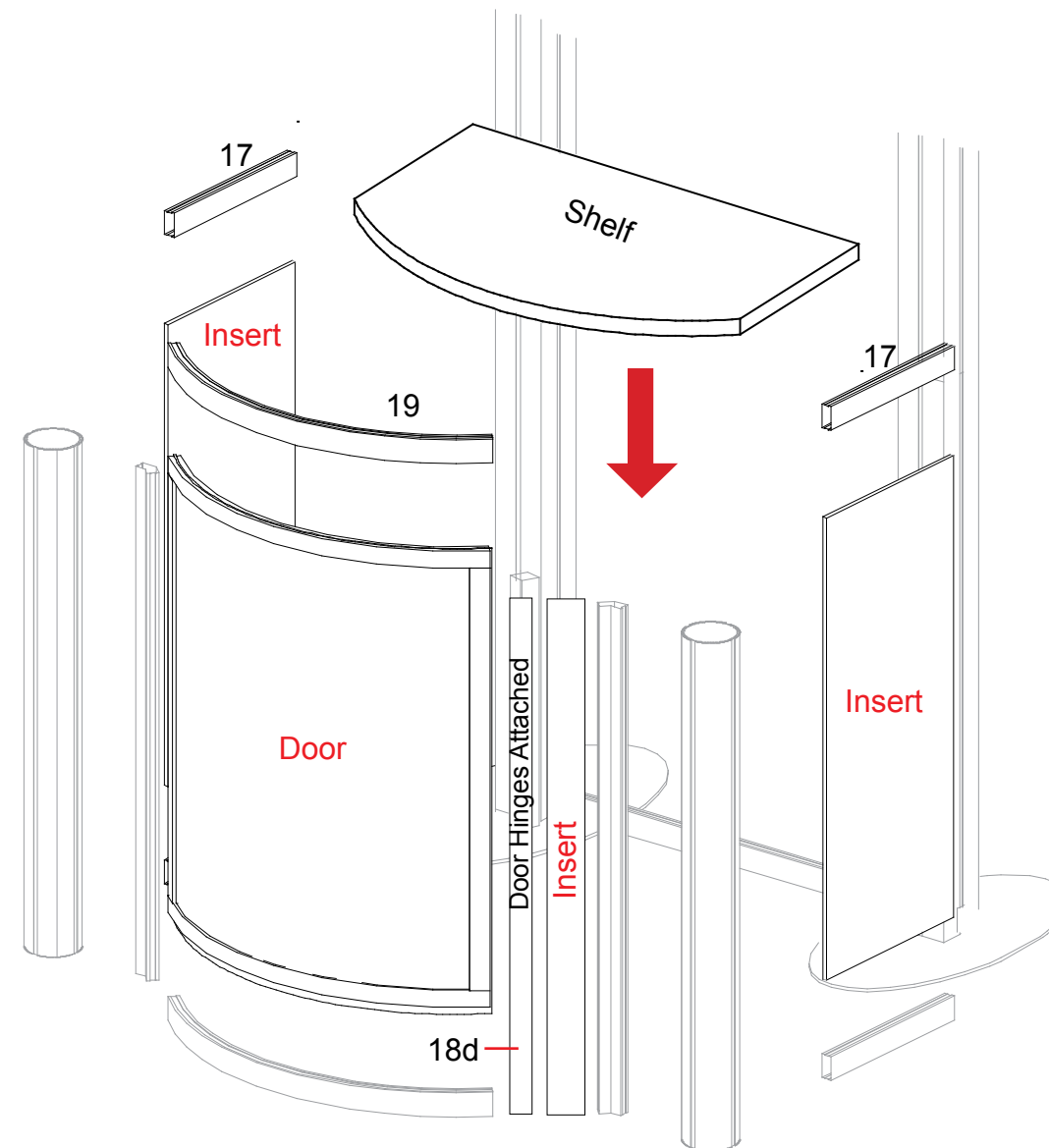
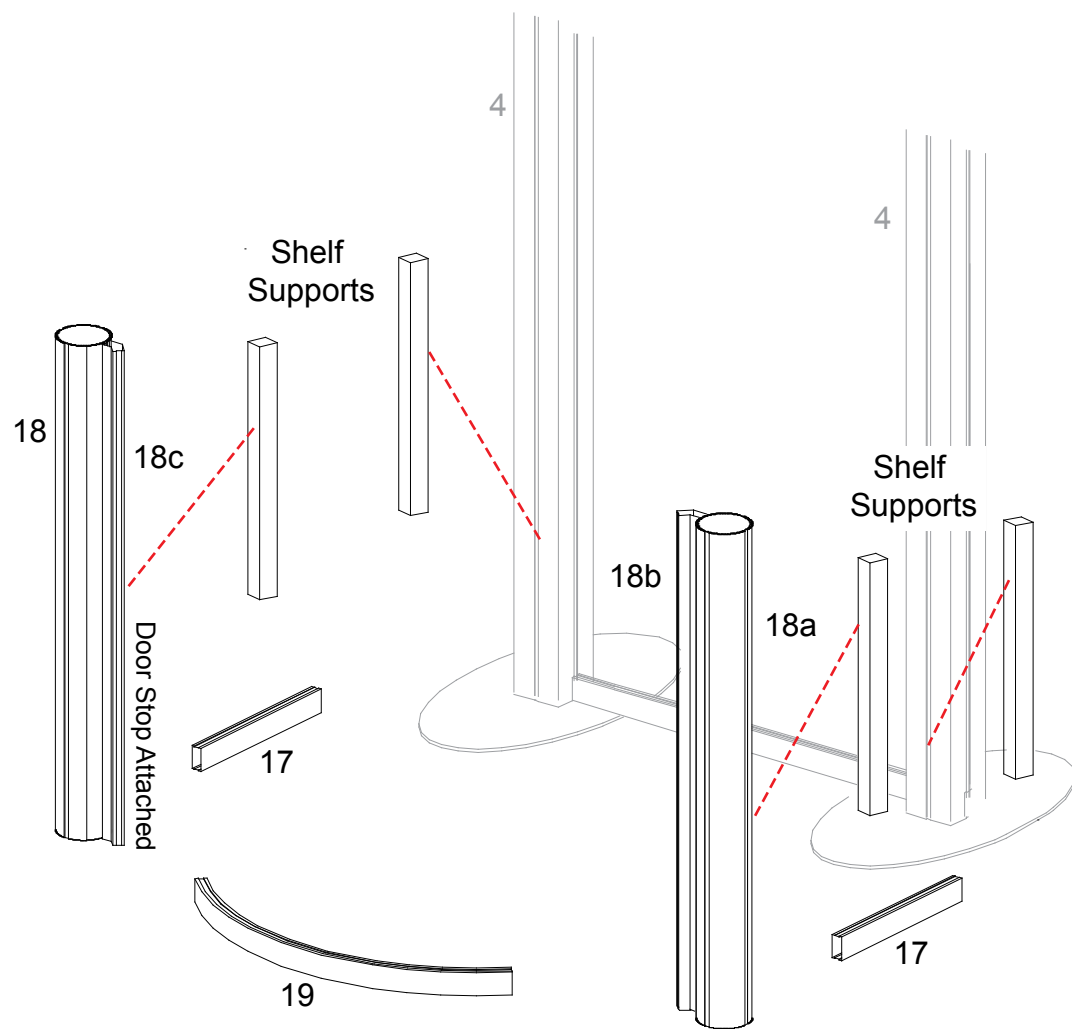
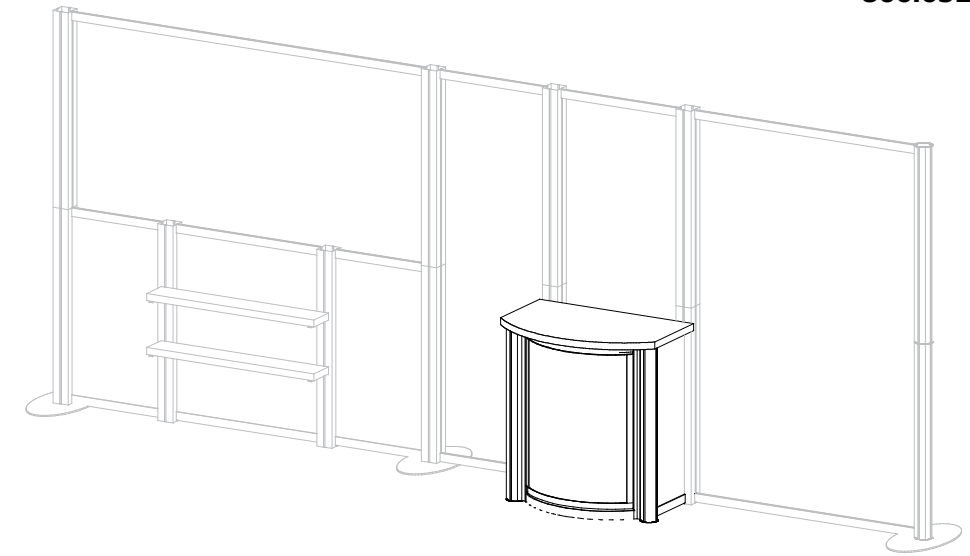

WHEN DISASSEMBLING ALUMINUM EXTRUSION, TIGHTEN ALL SETSCREWS AND LOCKS TO PREVENT LOSS DURING SHIPPING

866.652.2100

Item	Qty.	Description
20	2	5.862" w Vertical Extrusion w/ Velcro attached to Back of member
21	2	5.862" w Vertical Extrusion w/ Velcro attached to Back of member
22	2	38.5" w Curved Horizontal Extrusion w/ Velcro attached to Back of member
23	2	38.5" w Curved Horizontal Extrusion w/ Velcro attached to Back of member
24	2	37.74" w Horizontal Extrusion w/ Velcro attached to Back of member
25	2	37.74" w Horizontal Extrusion w/ Velcro attached to Back of member

Steps

- 1) Connect canopy pieces together using bolts and wing nuts provided, see Example of Canopy Connection detail.
- 2) Connect horizontal extrusions [22 to 23 and 24 to 25] together.
- 3) Attach assembled horizontal extrusion [24/25] to assembled canopy using bolts as shown.
- 4) Connect vertical extrusions [20 and 21] to left and right side of assembled horizontal extrusion [24/25].
- 5) Attach assembled curved horizontal extrusion [22/23] atop vertical extrusions [20 and 21].

***Repeat steps for additional canopy
 ***2nd one attaches B to B.

Example of Canopy Connection

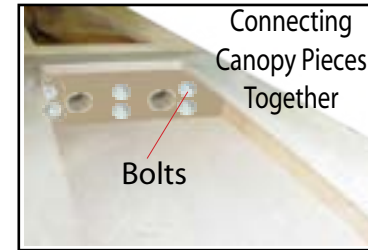

Connect 2 piece Canopy together by using bolts and wing nuts provided.

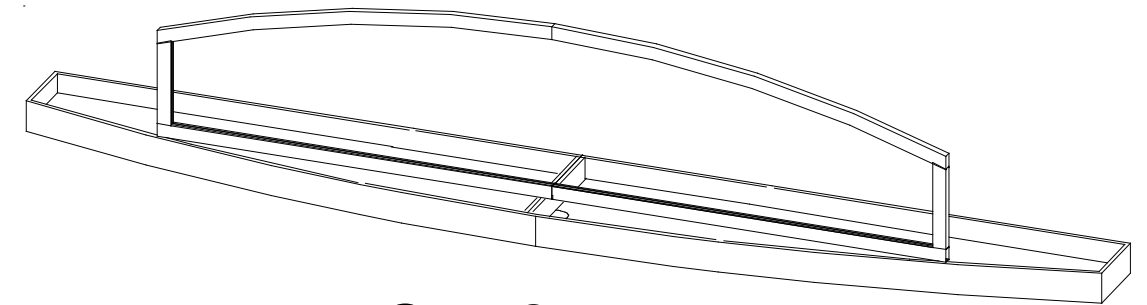

Qty. 2

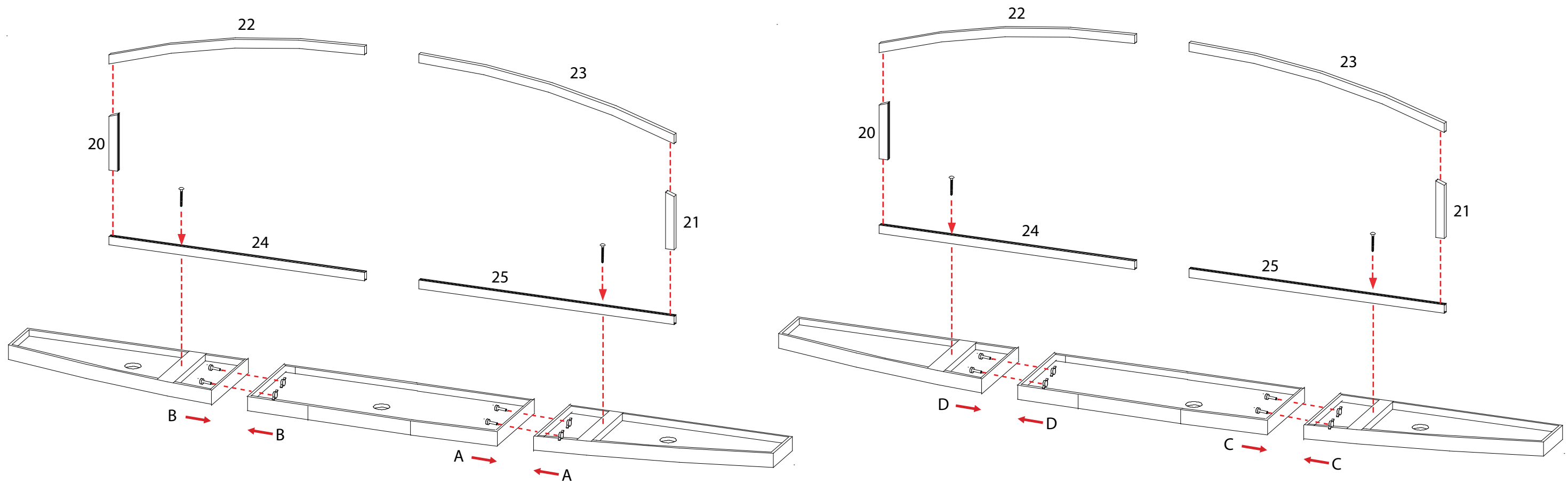

WHEN DISASSEMBLING ALUMINUM EXTRUSION, TIGHTEN ALL SETSCREWS AND LOCKS TO PREVENT LOSS DURING SHIPPING

866.652.2100

Item	Qty.	Description
26	4	Shelf Supports

Steps

- 1) Attach canopy to assembled backwall as shown.
- 2) Attach 20"D sintra signs using standoff barrels and caps.
- 3) Attach wings using A10 clamps as shown.
- 4) Attach literature racks as shown.
- 5) Connect shelf supports [26] to vertical extrusions [8 from page 1] and place shelves atop shelf supports and secure in place with screw caps.

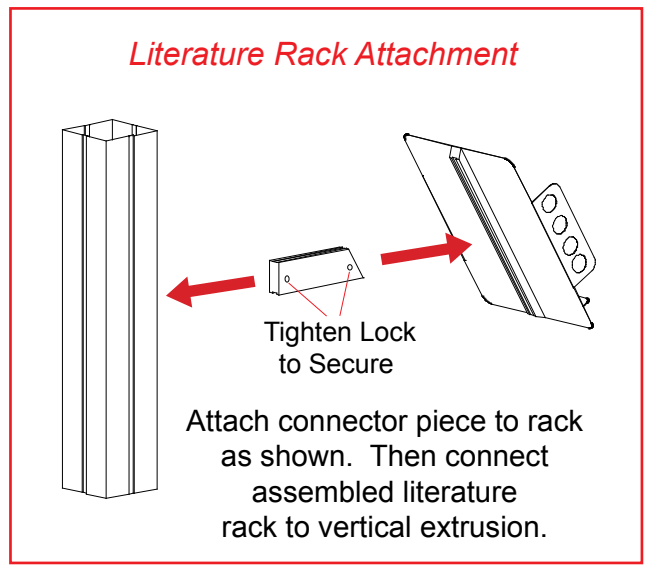
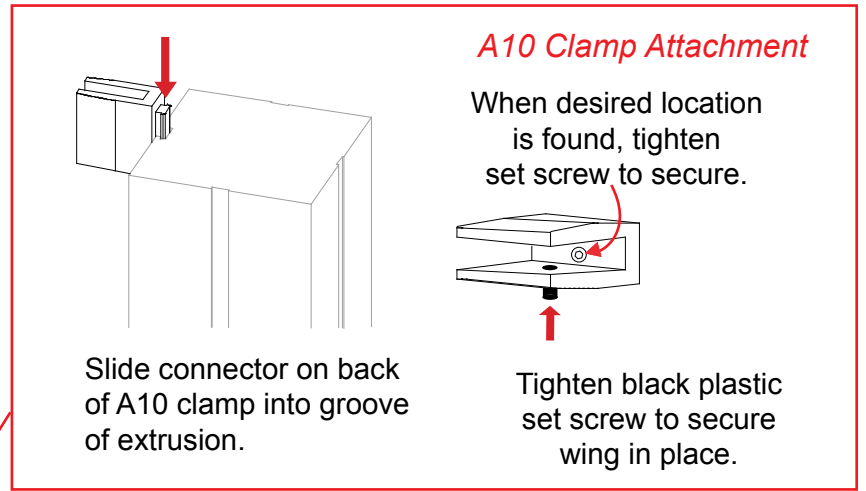
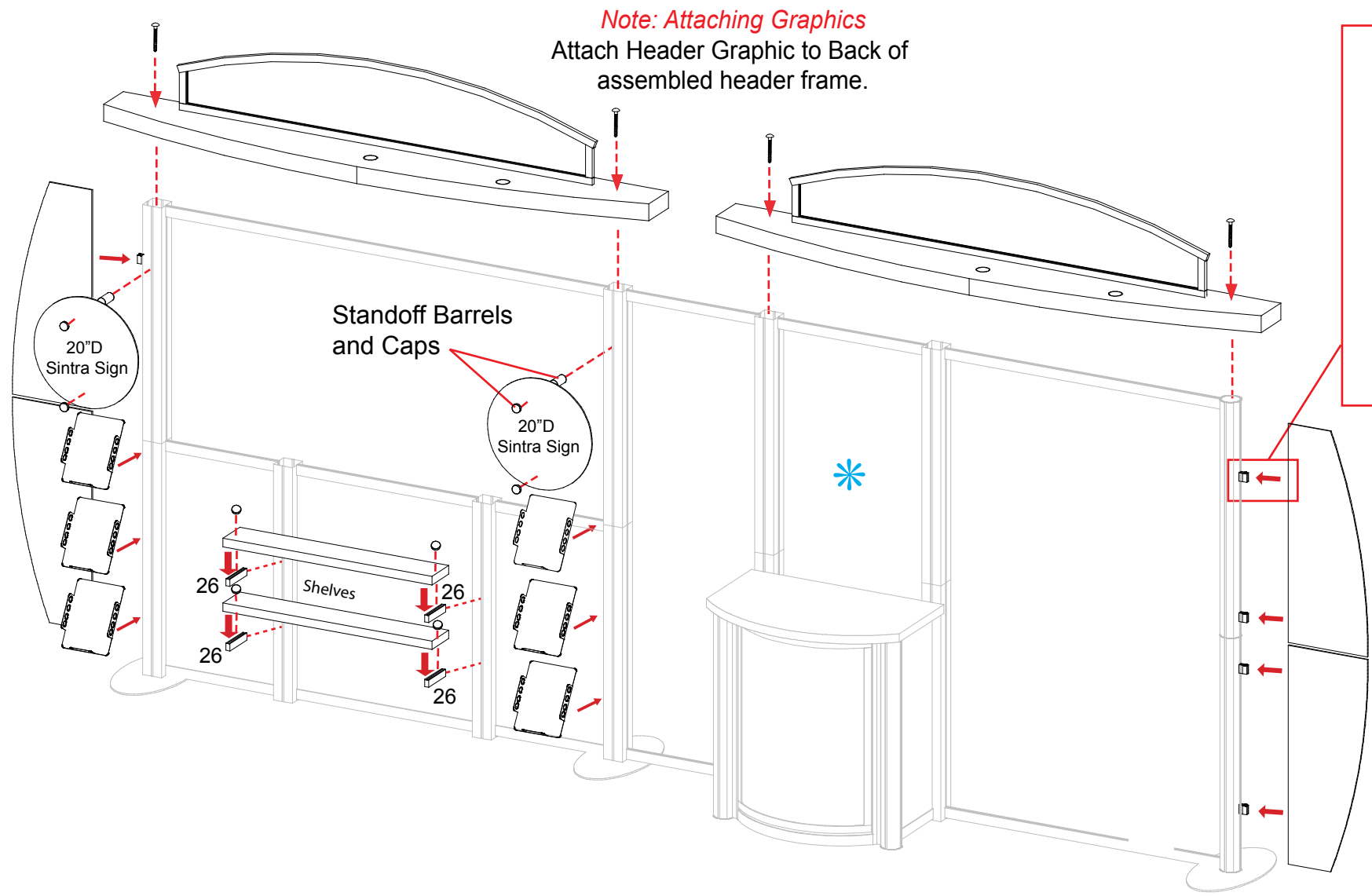
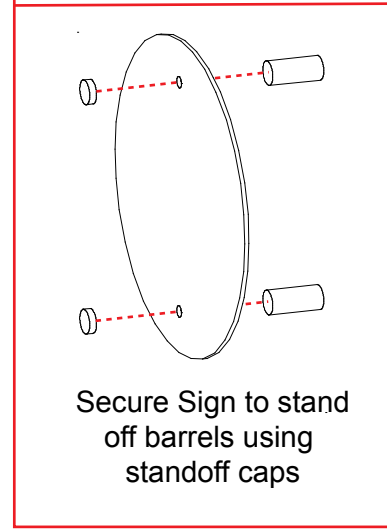
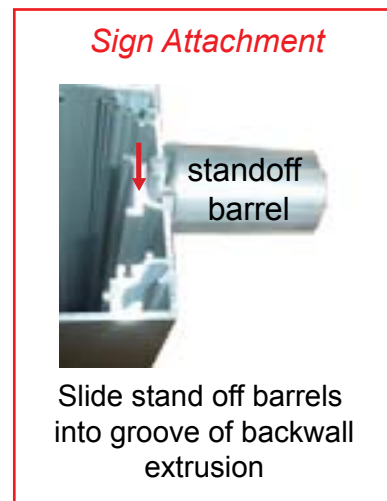
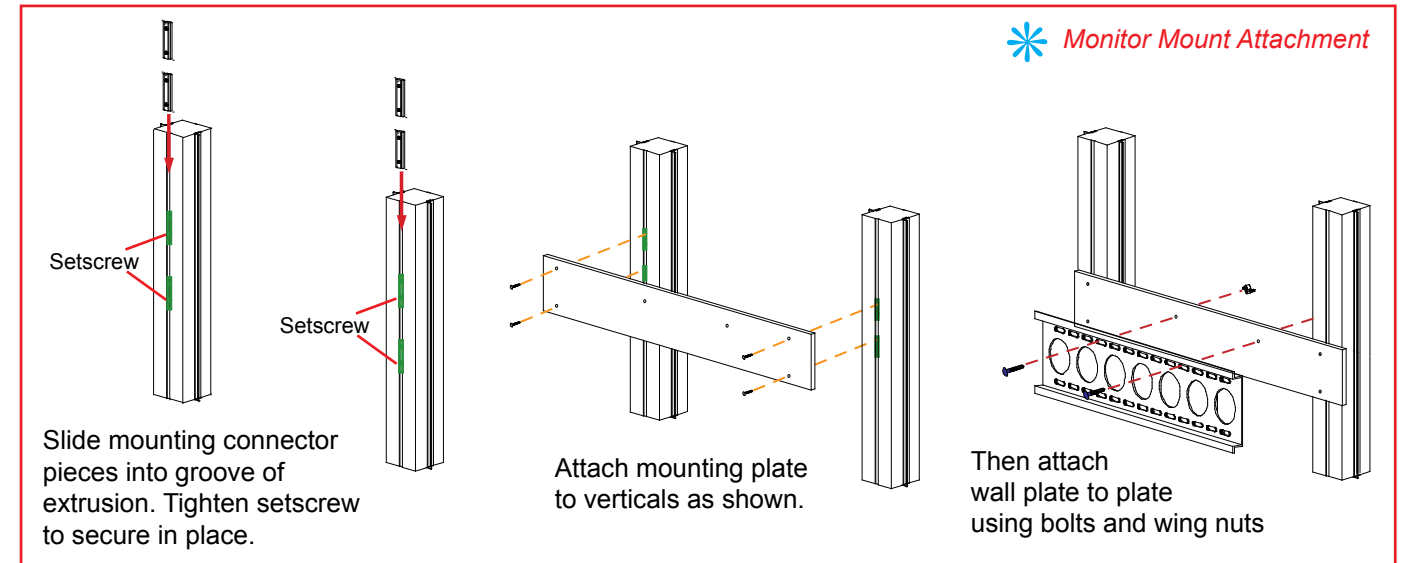

WHEN DISASSEMBLING ALUMINUM EXTRUSION, TIGHTEN ALL SETSCREWS AND LOCKS TO PREVENT LOSS DURING SHIPPING

866.652.2100

Item	Qty.	Description
27	1	18"D Round Base Plate
28	1	36"h Round Vertical Extrusion
29	1	40"h Lower Round Vertical Extrusion
30	1	40"h Upper Round Vertical Extrusion

Steps

- 1) Attach vertical extrusions [28 and 29] to base plate [27] as shown.
- 2) Attach upper vertical extrusion [30] atop vertical extrusion [29].
- 3) Attach tapered plex wing to front of vertical extrusion [28] using standoff caps and 16"D round sintra sign to vertical extrusion [30].
- 4) Place and attach counter atop vertical extrusion [28].

Repeat steps for both workstations.

Monitor Mount Attachment *

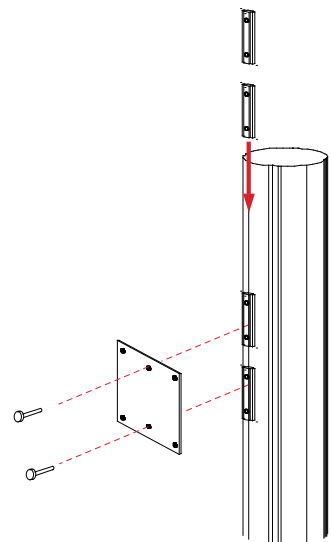

Slide mounting connector pieces into groove of extrusion. Tighten setscrew to secure in place.

Attach back plate to connectors on vertical extrusion using screws. Then attach top plate and tighten setscrews to secure.

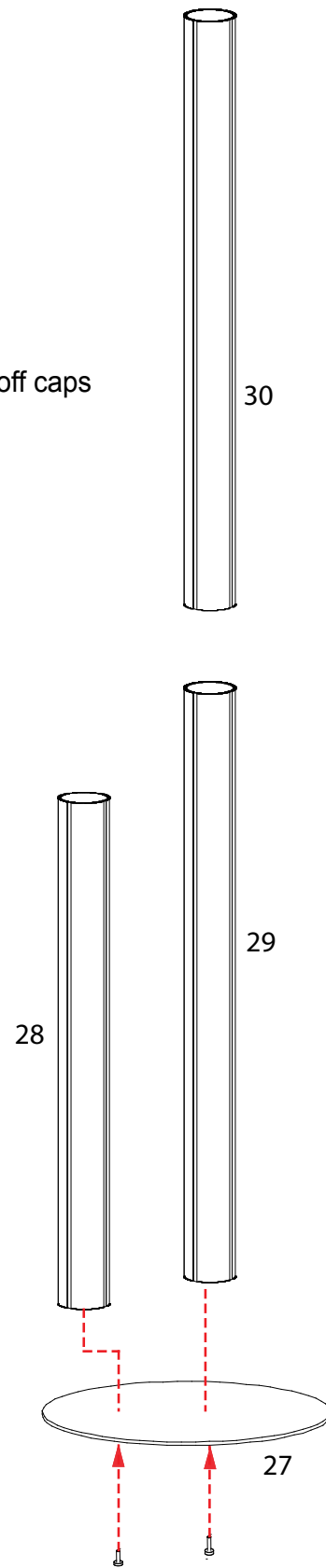

Sign Attachment

Slide stand off barrels into groove of vertical extrusion

Secure Sign to stand off barrels using stand off caps

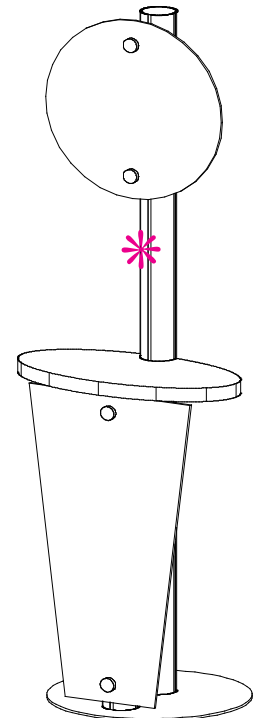
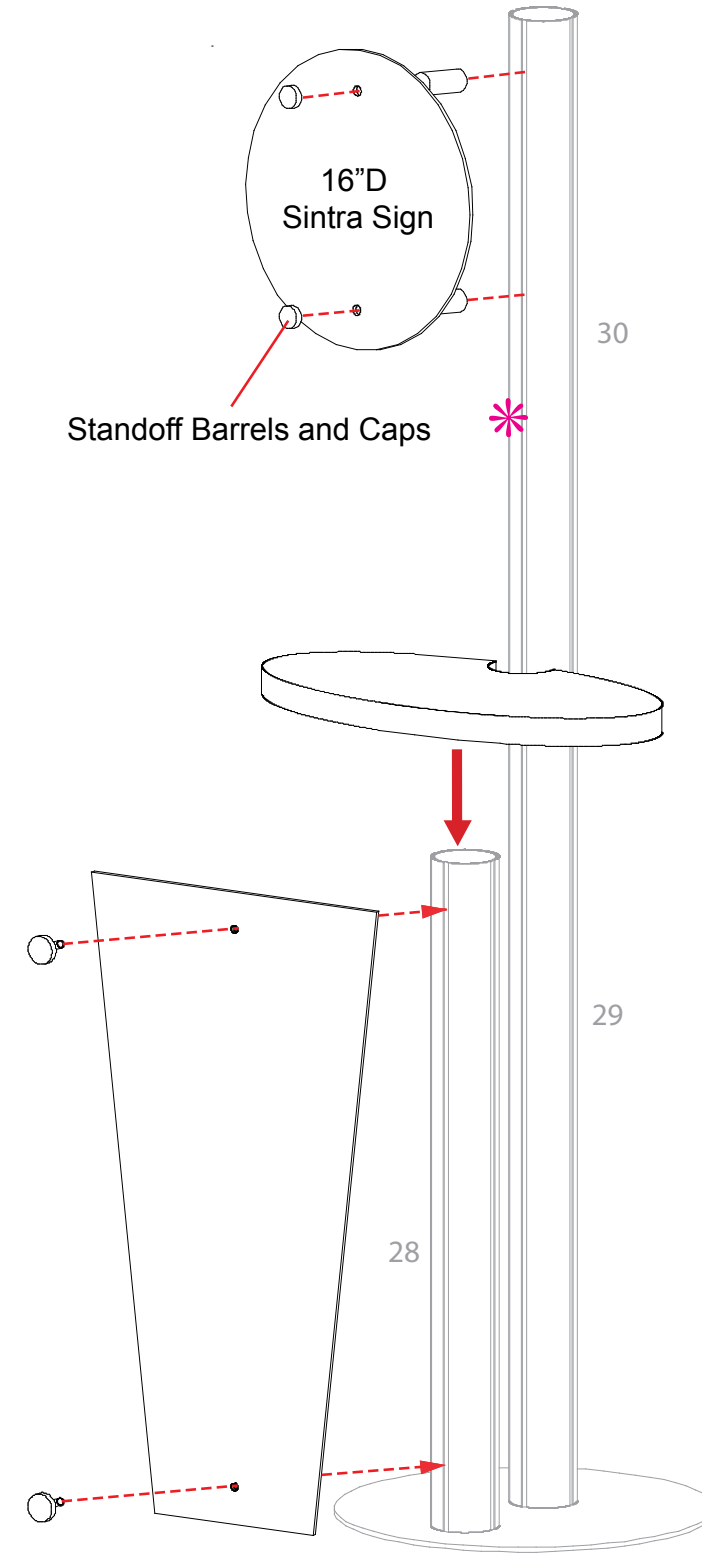

Qty. 2

WHEN DISASSEMBLING ALUMINUM EXTRUSION, TIGHTEN ALL SETSCREWS AND LOCKS TO PREVENT LOSS DURING SHIPPING

Top View of Each Level

10x10 Right Backwall Components

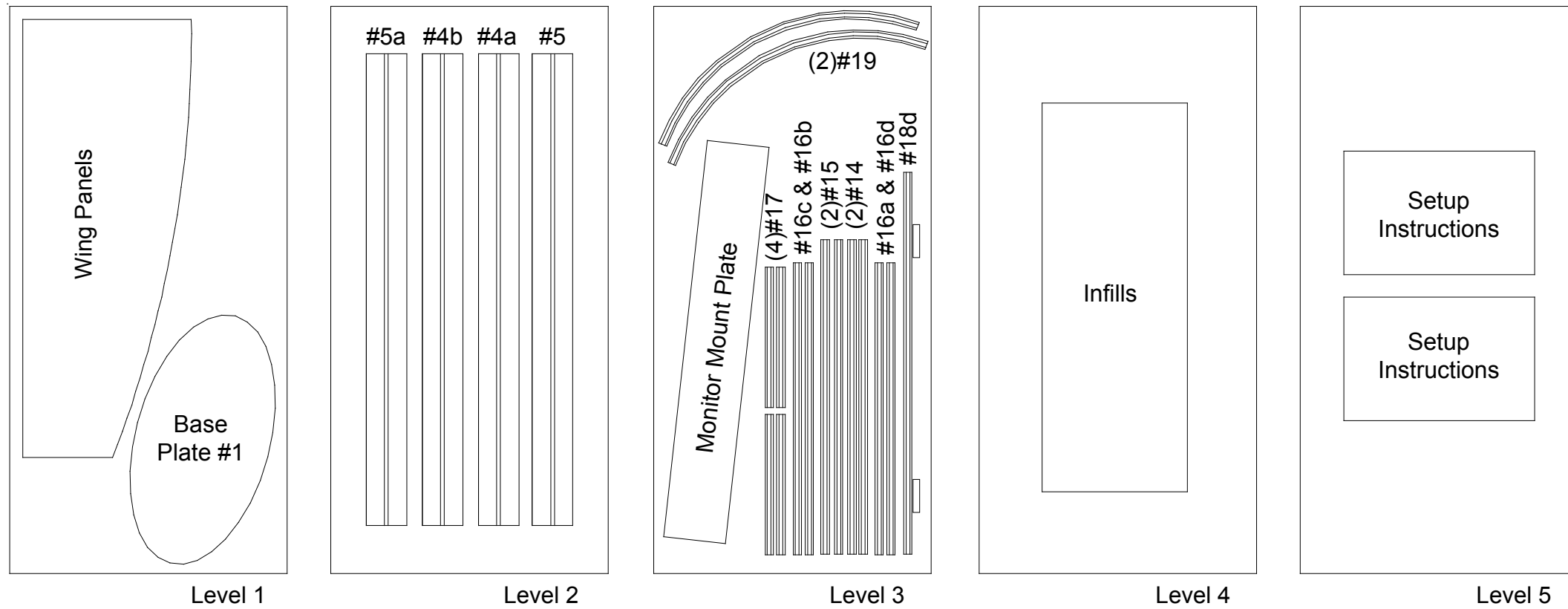

WHEN DISASSEMBLING ALUMINUM EXTRUSION, TIGHTEN ALL SETSCREWS AND LOCKS TO PREVENT LOSS DURING SHIPPING

Top View of Each Level

10x10 Right Backwall Components

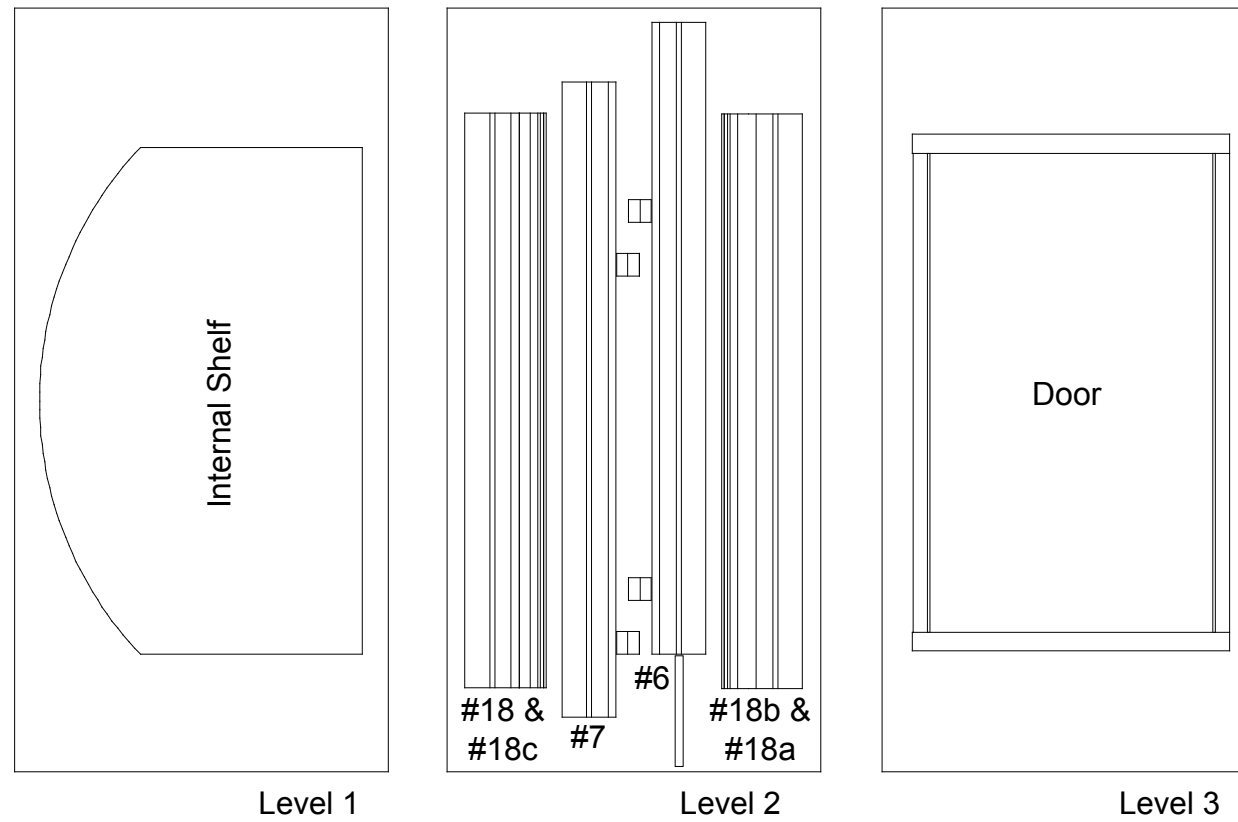

WHEN DISASSEMBLING ALUMINUM EXTRUSION, TIGHTEN ALL SETSCREWS AND LOCKS TO PREVENT LOSS DURING SHIPPING

Top View of Each Level

10x10 Right Backwall Components

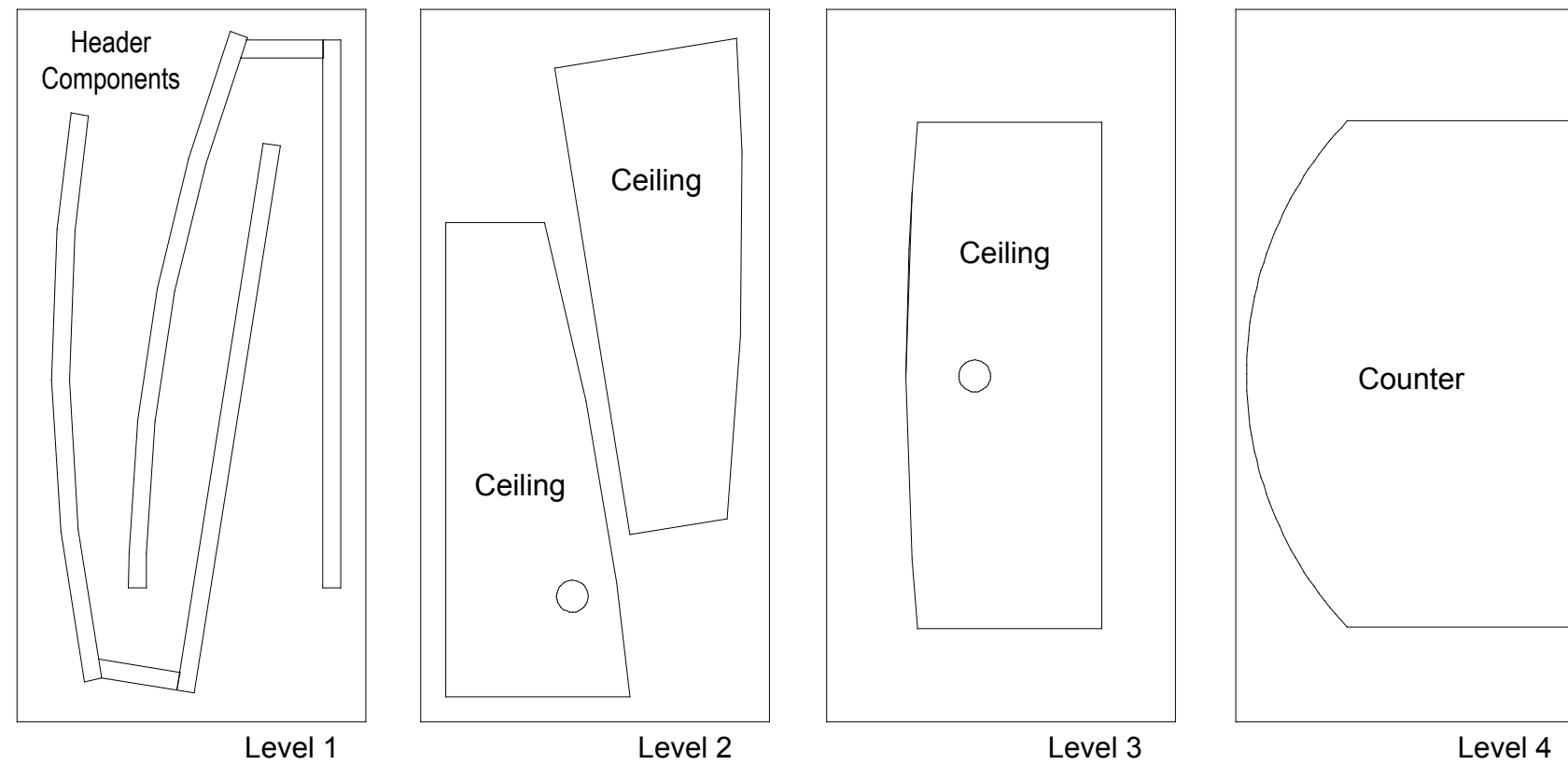

WHEN DISASSEMBLING ALUMINUM EXTRUSION, TIGHTEN ALL SETSCREWS AND LOCKS TO PREVENT LOSS DURING SHIPPING

Top View of Each Level

Workstation Components

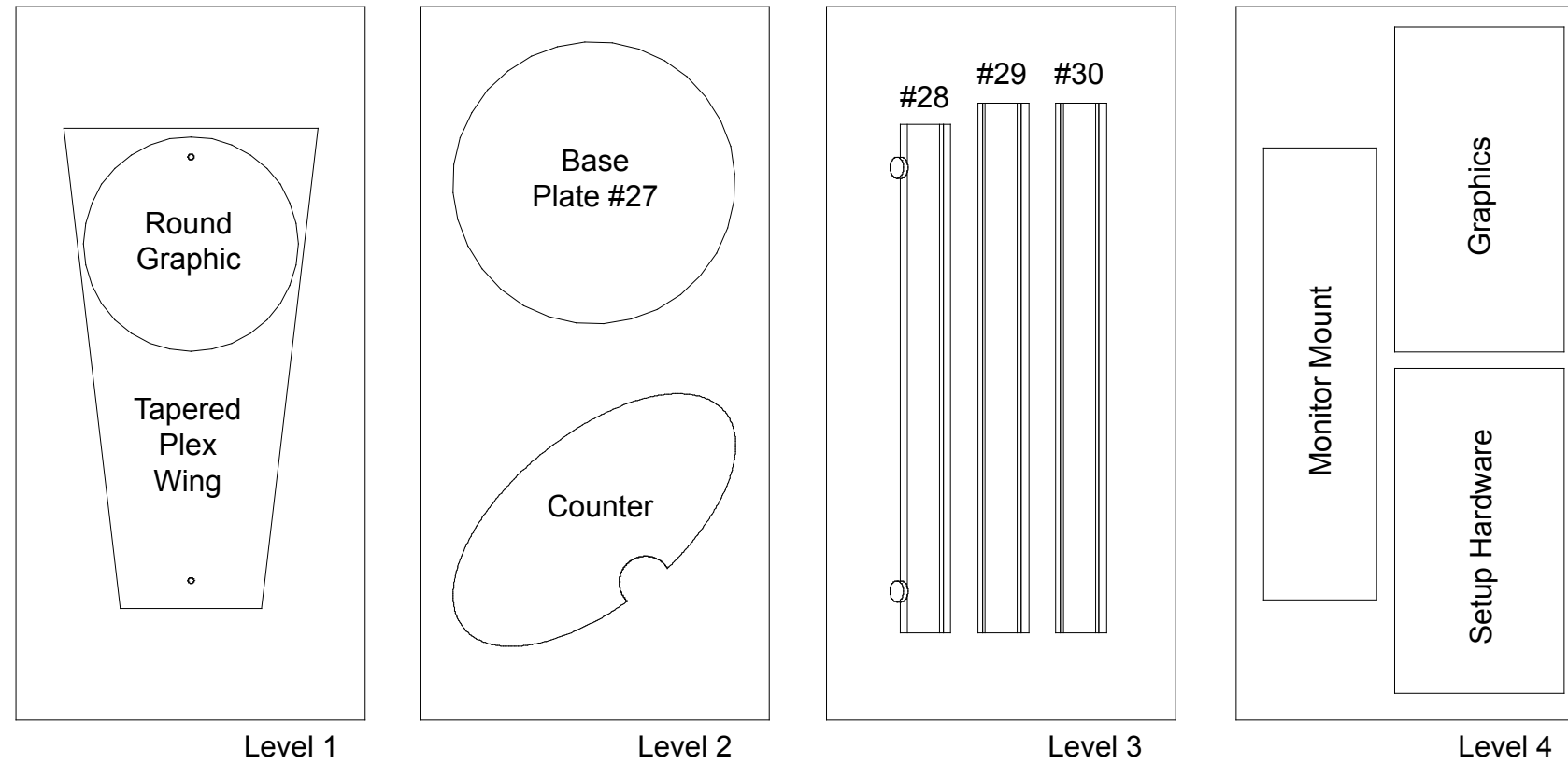

WHEN DISASSEMBLING ALUMINUM EXTRUSION, TIGHTEN ALL SETSCREWS AND LOCKS TO PREVENT LOSS DURING SHIPPING

Top View of Each Level

10x10 Left Backwall Components

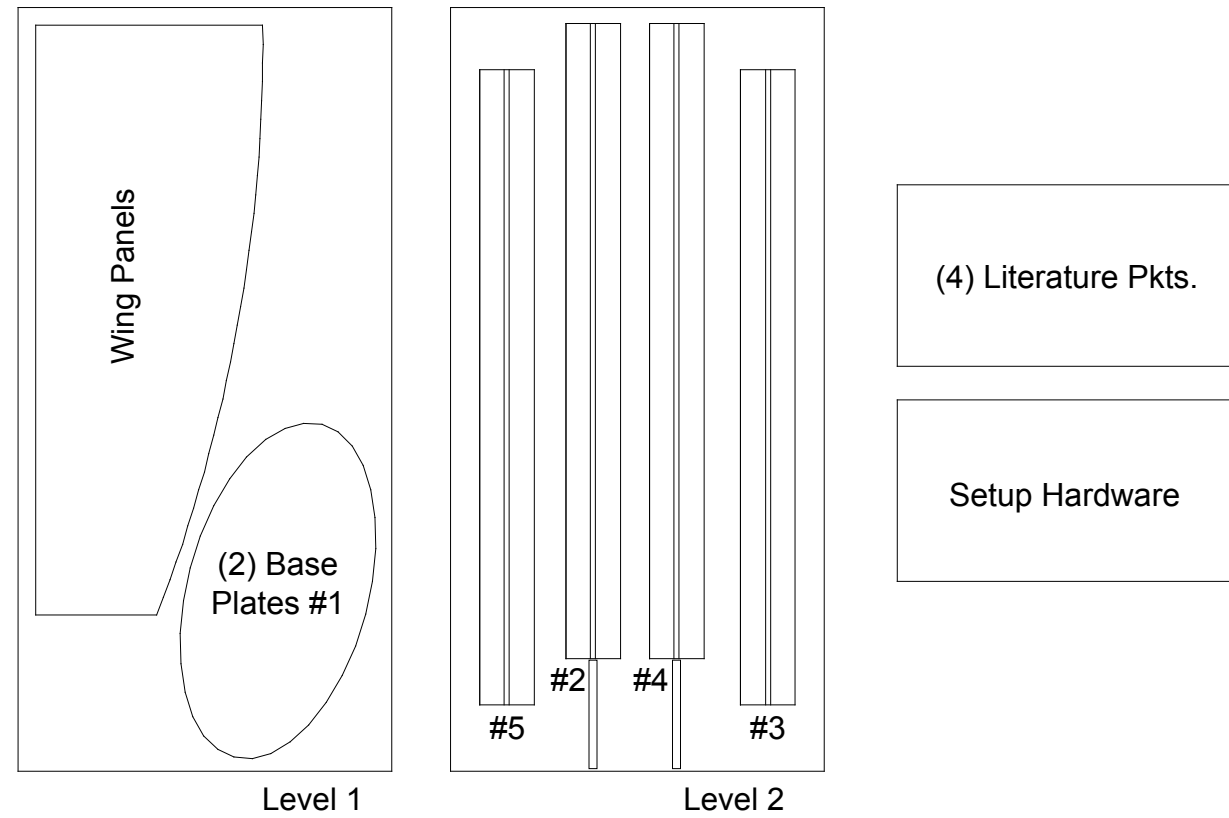

WHEN DISASSEMBLING ALUMINUM EXTRUSION, TIGHTEN ALL SETSCREWS AND LOCKS TO PREVENT LOSS DURING SHIPPING

Top View of Each Level

10x10 Left Backwall Components

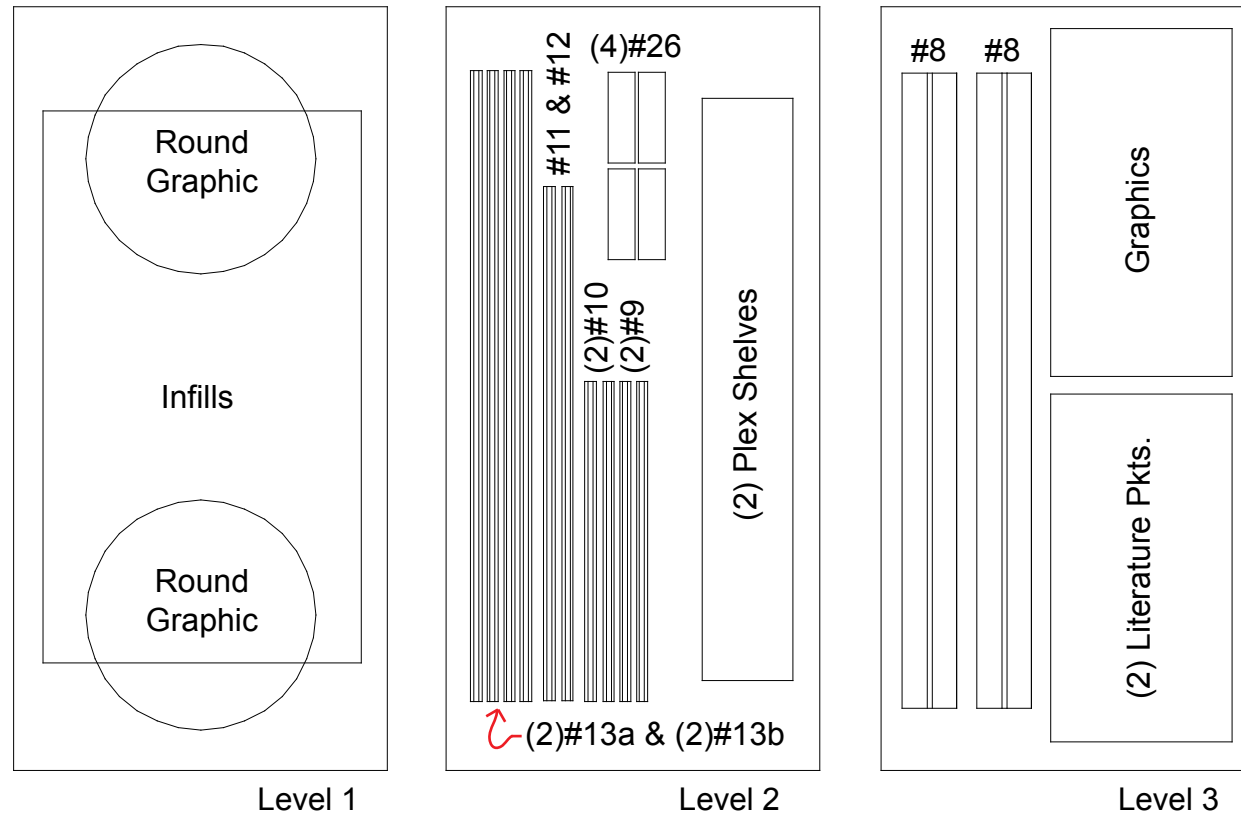

WHEN DISASSEMBLING ALUMINUM EXTRUSION, TIGHTEN ALL SETSCREWS AND LOCKS TO PREVENT LOSS DURING SHIPPING

Top View of Each Level

10x10 Left Backwall Components

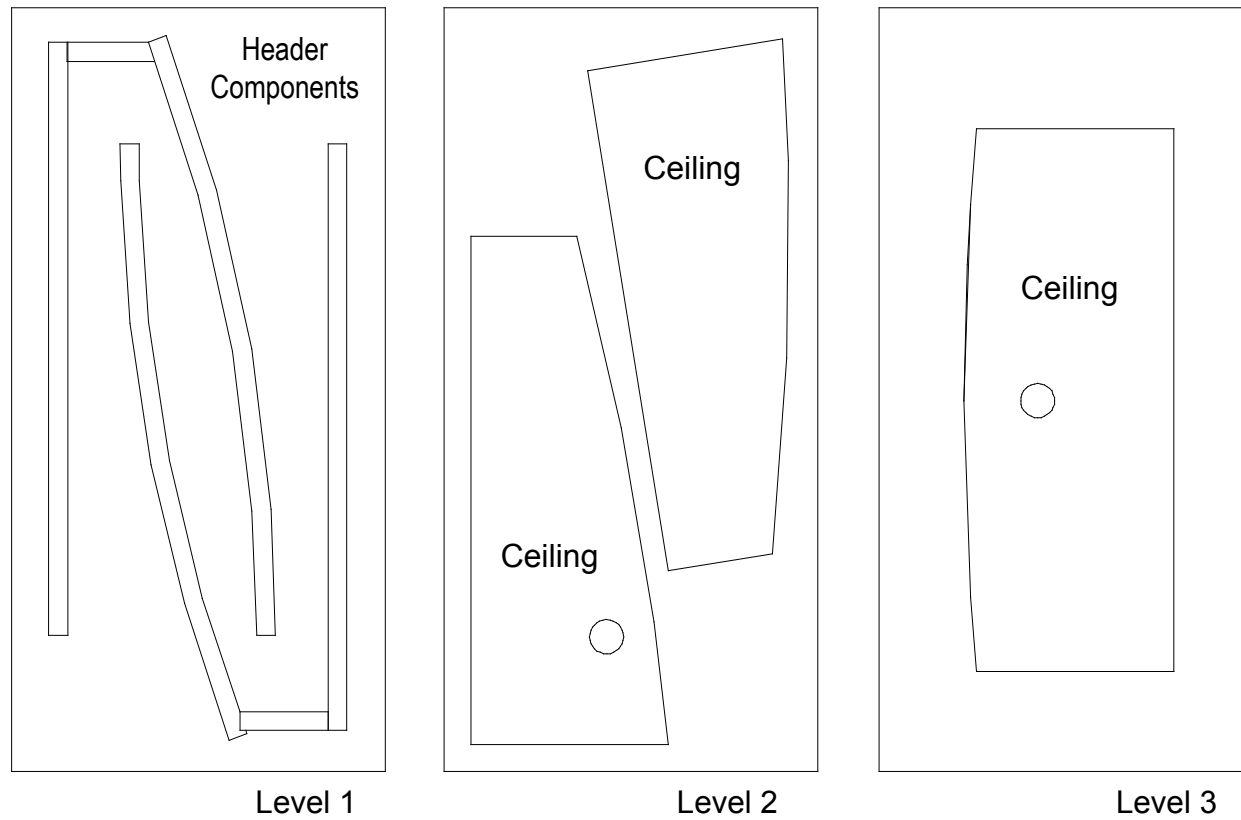

WHEN DISASSEMBLING ALUMINUM EXTRUSION, TIGHTEN ALL SETSCREWS AND LOCKS TO PREVENT LOSS DURING SHIPPING

Top View of Each Level

Workstation Components

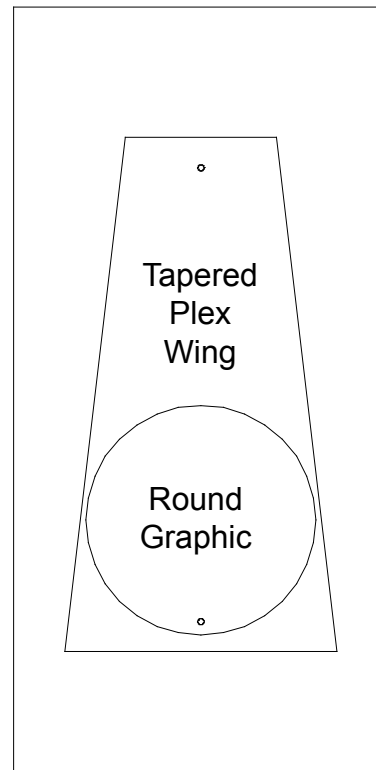

Level 1

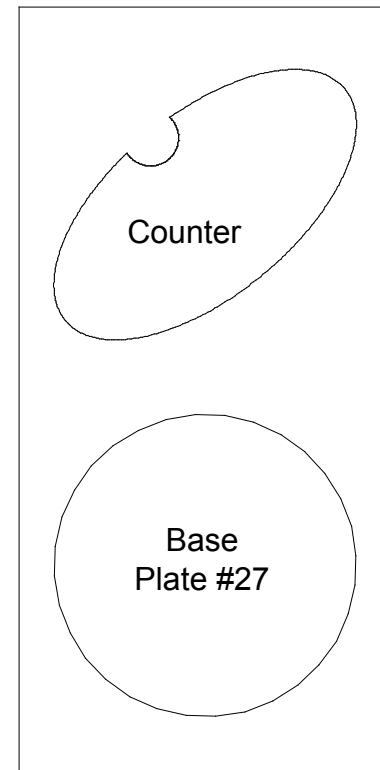

Level 2

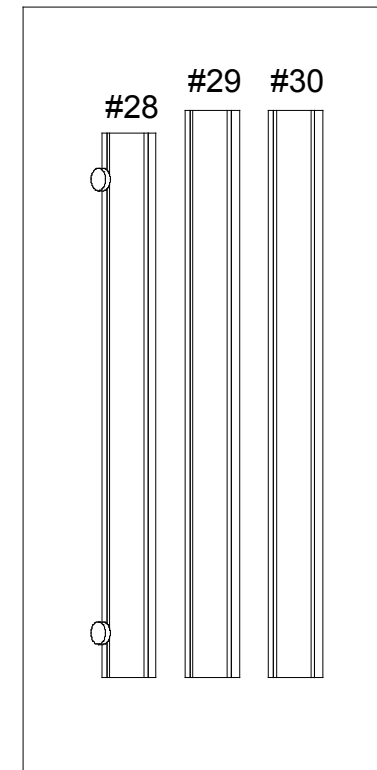

Level 3

WHEN DISASSEMBLING ALUMINUM EXTRUSION, TIGHTEN ALL SETSCREWS AND LOCKS TO PREVENT LOSS DURING SHIPPING