

visionary™ DESIGNS

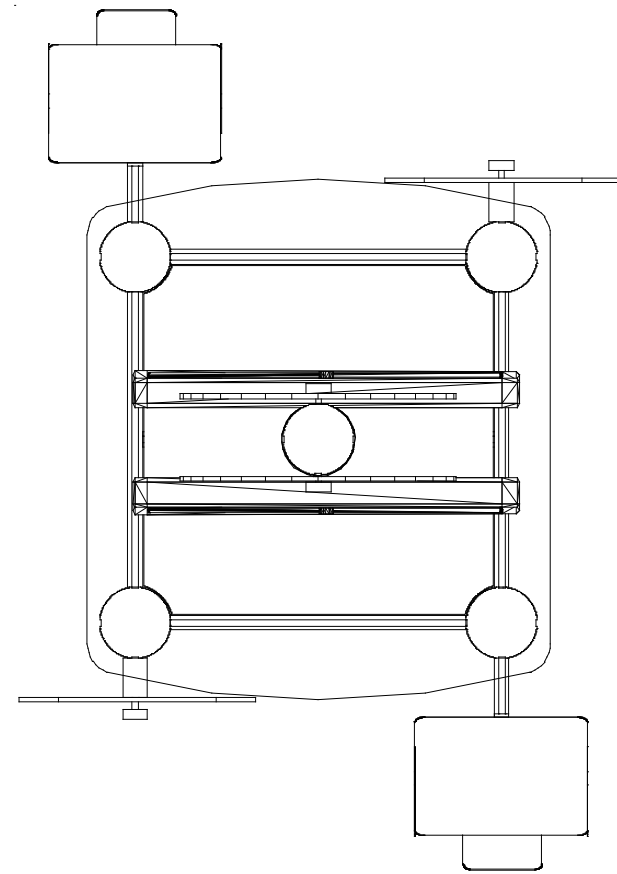

Top View

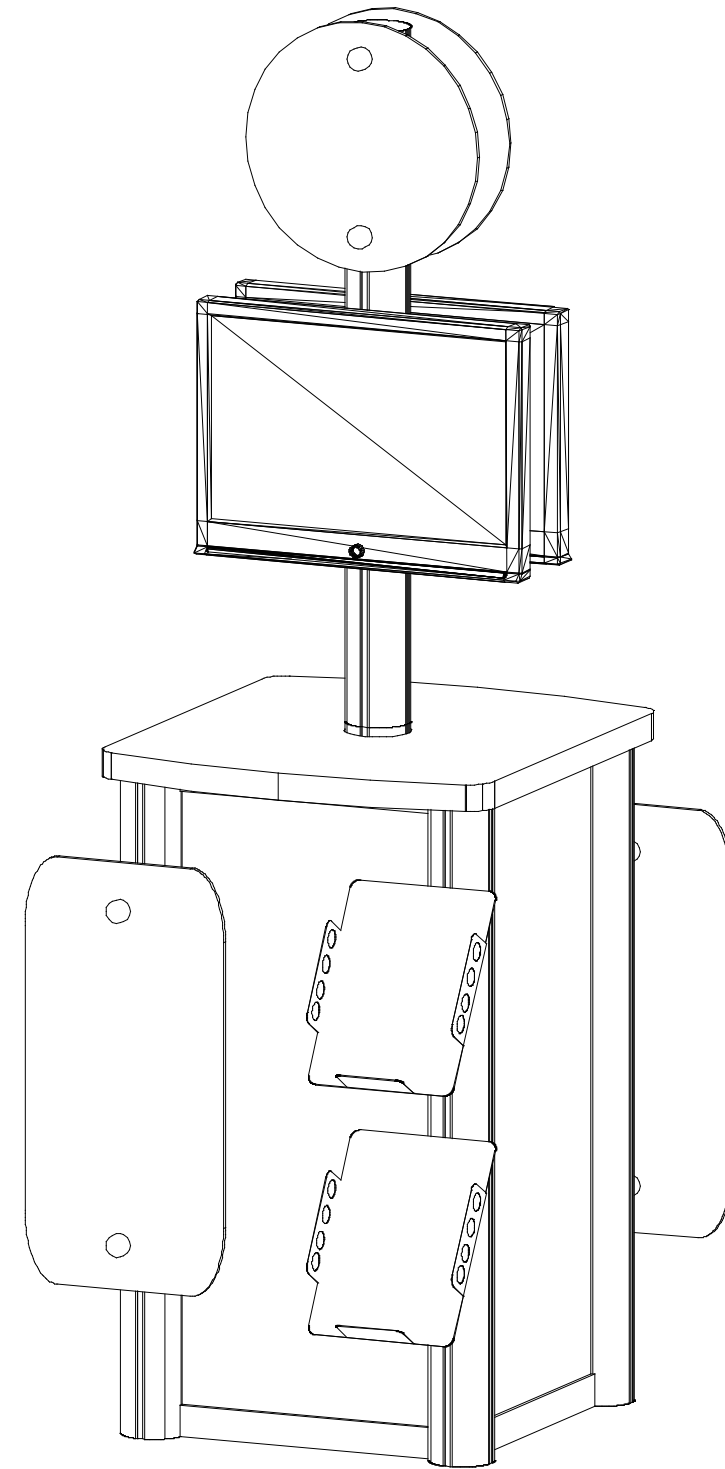

WHEN DISASSEMBLING ALUMINUM EXTRUSION, TIGHTEN ALL SETSCREWS AND LOCKS TO PREVENT LOSS DURING SHIPPING



Using Your Setup Instructions

The Visionary Designs Setup Instructions are created specifically for your configuration. They are laid out sequentially, including an exploded view of the entire display, and then a logical series of detailed steps to assemble the main structure and components. We encourage you to study the instructions **before** attempting to assemble your exhibit.

Each page reminds you to tighten the setscrews after disassembling your exhibit to prevent loss of the locks and setscrews (see below in RED). This is VERY IMPORTANT.

Cleaning and Packing Your Display

- 1) Use care when cleaning aluminum extrusion or acrylic inserts. Use only non-abrasive cleaners.
- 2) When cleaning laminate inserts or countertops, use mild cleansers and a soft material such as cotton.
- 3) Keep all display components away from extreme heat and long exposure to sunlight to avoid warping and fading.
- 4) Retain all packing material. It will make re-packing much easier and will reduce the likelihood of shipping damage.



Most Visionary Designs exhibits can be assembled with the supplied Hex Key Tool. Occasionally, a flat head screwdriver may be required.

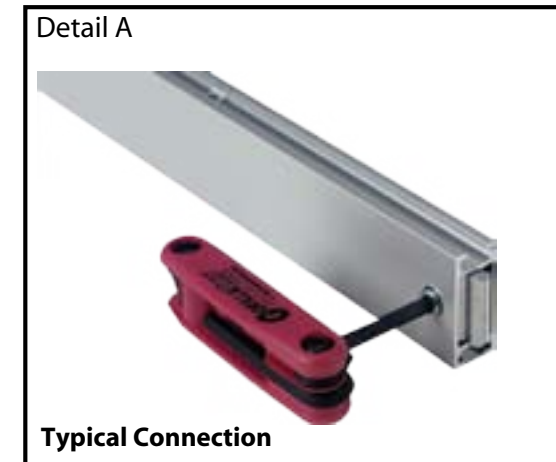

Most horizontal extrusion connections have a patented expandable lock. This lock inserts into the groove of an opposing extrusion. Tightening the lock with the Hex Key Tool expands the lock and creates a strong positive connection.

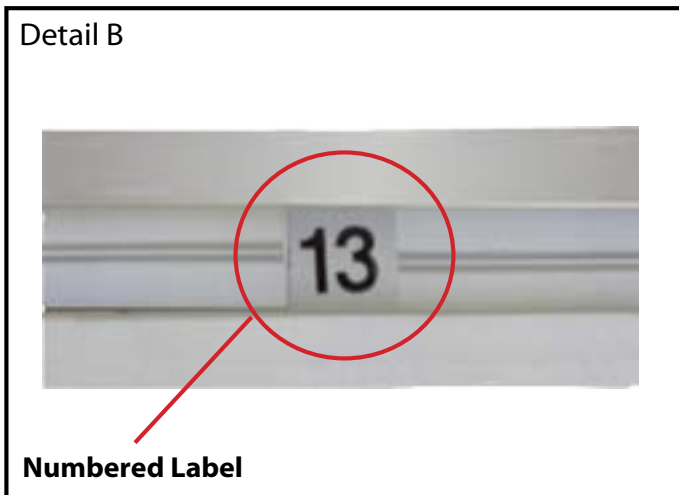

Each extrusion contains a numbered label which corresponds with setup instructions.

The label is located within a groove of the extrusion (when possible). With Visionary Designs the labels contain Black numbers unless otherwise specified.



Remove only (1) setscrew when disassembling. Replace setscrew in extrusion after assembling it. Before packing, replace setscrew in extrusion to avoid losing it.

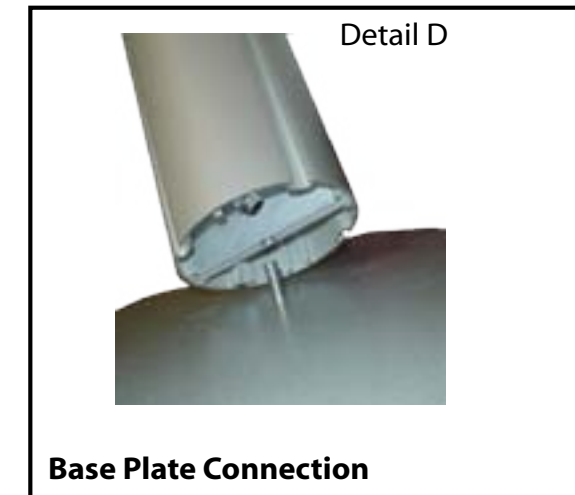

Attach base plate to round or square vertical extrusion using the bolt provided. Be careful not to strip the threads.

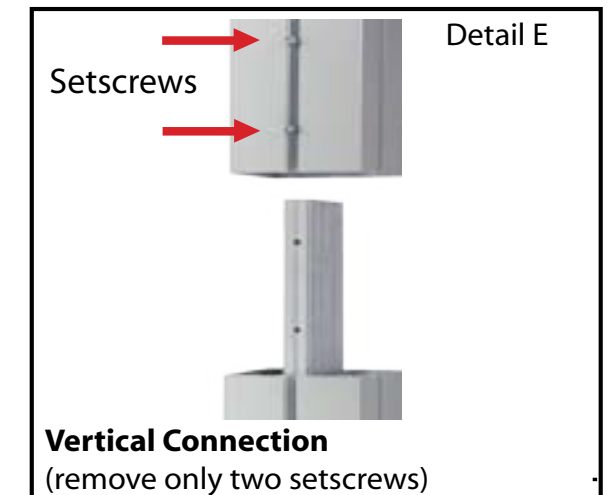

When vertical extrusions are packed in portable cases rather than crates or tubs, they must be broken down into smaller sections which then require assembly.

Remove only (2) setscrews when disassembling. Replace setscrews in extrusion after assembling it. Before packing, replace setscrews in extrusion to avoid losing them.

WHEN DISASSEMBLING ALUMINUM EXTRUSION, TIGHTEN ALL SETSCREWS AND LOCKS TO PREVENT LOSS DURING SHIPPING

866.652.2100

Items	Qty.	Description
1	1	38" h Circular Vertical Extrusion
2	1	38" h Circular Vertical Extrusion
3	1	38" h Circular Vertical Extrusion
4	1	38" h Circular Vertical Extrusion
5	1	15" w Lower Horizontal Extrusion
6	1	15" w Lower Horizontal Extrusion
7	1	15" w Lower Horizontal Extrusion
8	1	15" w Lower Horizontal Extrusion
9/10	1/1	7" w Pole Supports
11/12	1/1	39" h Lower Pole/Upper Pole
13	1	15" w Upper Horizontal Extrusion
14	1	15" w Upper Horizontal Extrusion
15	1	15" w Upper Horizontal Extrusion
16	1	15" w Upper Horizontal Extrusion

Steps:

- 1) Attach lower horizontal extrusions [5,6,7,8] to circular vertical extrusions [1,2,3,4] as shown.
- 2) Attach pole supports [9 and 10] to the lower pole [11] and to lower horizontal extrusions [6 and 8].
- 3) Attach shelf supports to velcro on the insides of the circular vertical extrusion.
- 4) Insert panels, attach door, and set shelf into place.
- 5) Attach upper vertical extrusions [13,14,15,16] to circular vertical extrusions as shown.
- 6) Attach upper pole [12] to lower pole [11].
- 7) Set counter top in place as shown.

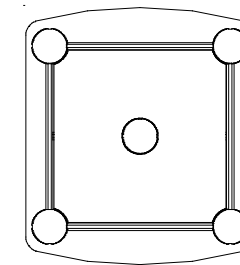
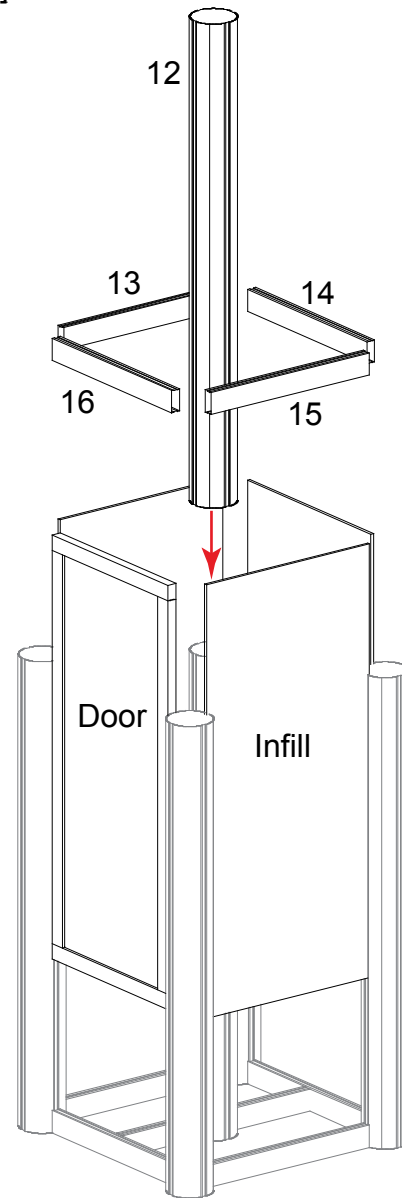
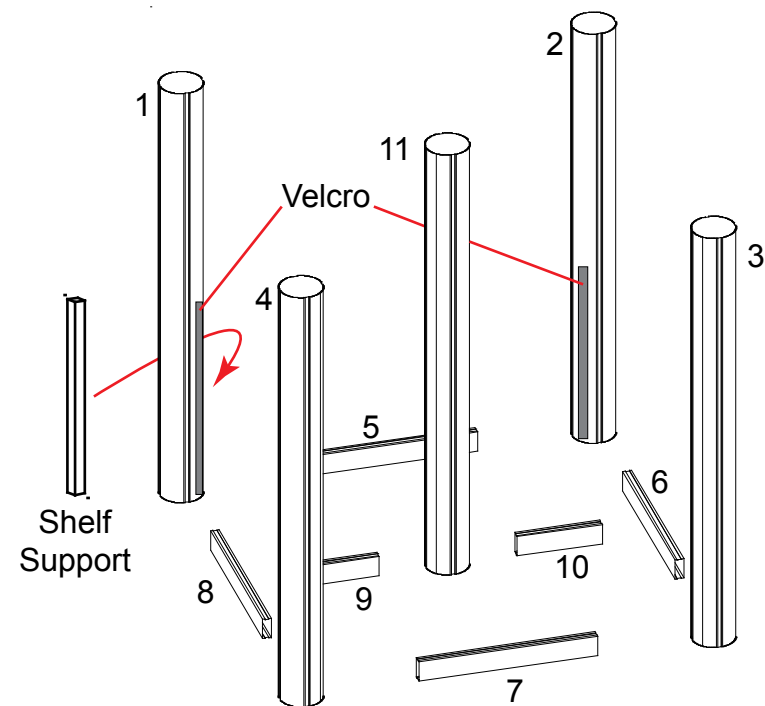

Top View

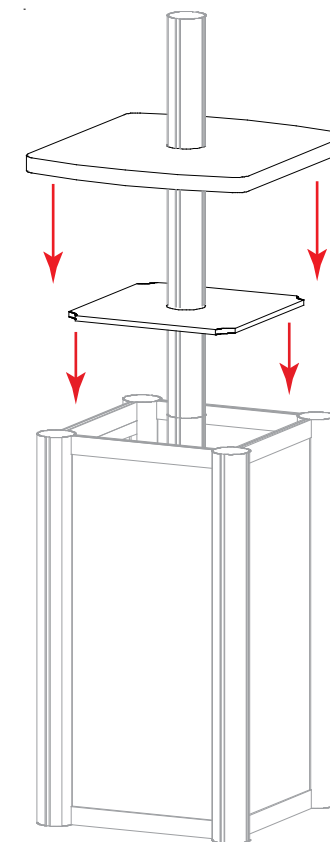
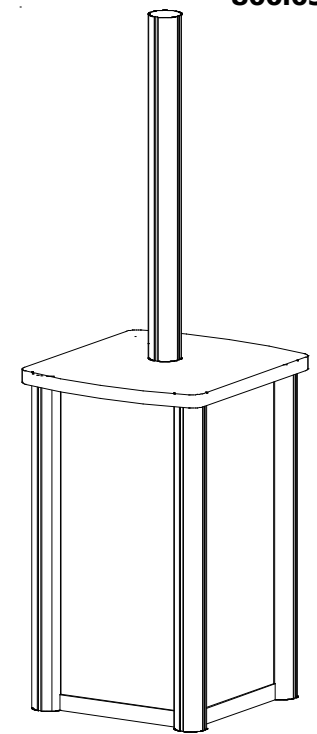

Counter Top

Internal Shelf

WHEN DISASSEMBLING ALUMINUM EXTRUSION, TIGHTEN ALL SETSCREWS AND LOCKS TO PREVENT LOSS DURING SHIPPING

*** Graphic Attachment**

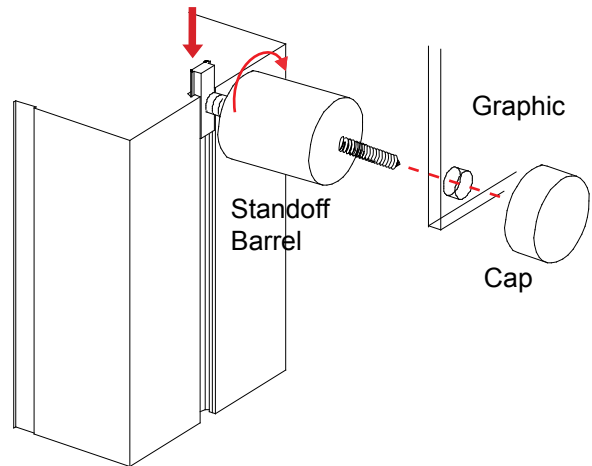

Slide connector on back of standoff barrels into groove of extrusion and twist to secure in place. Secure graphic to standoffs using screw caps.

*** Literature Rack Attachment**

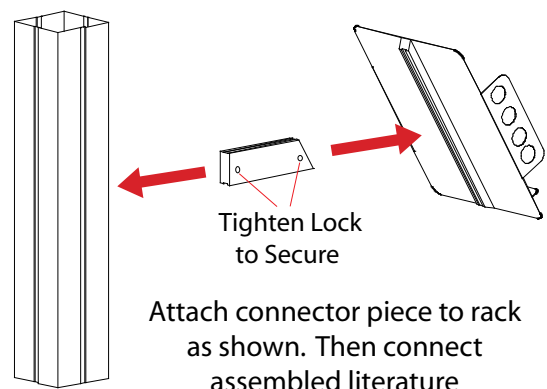

Attach connector piece to rack as shown. Then connect assembled literature rack to vertical extrusion.

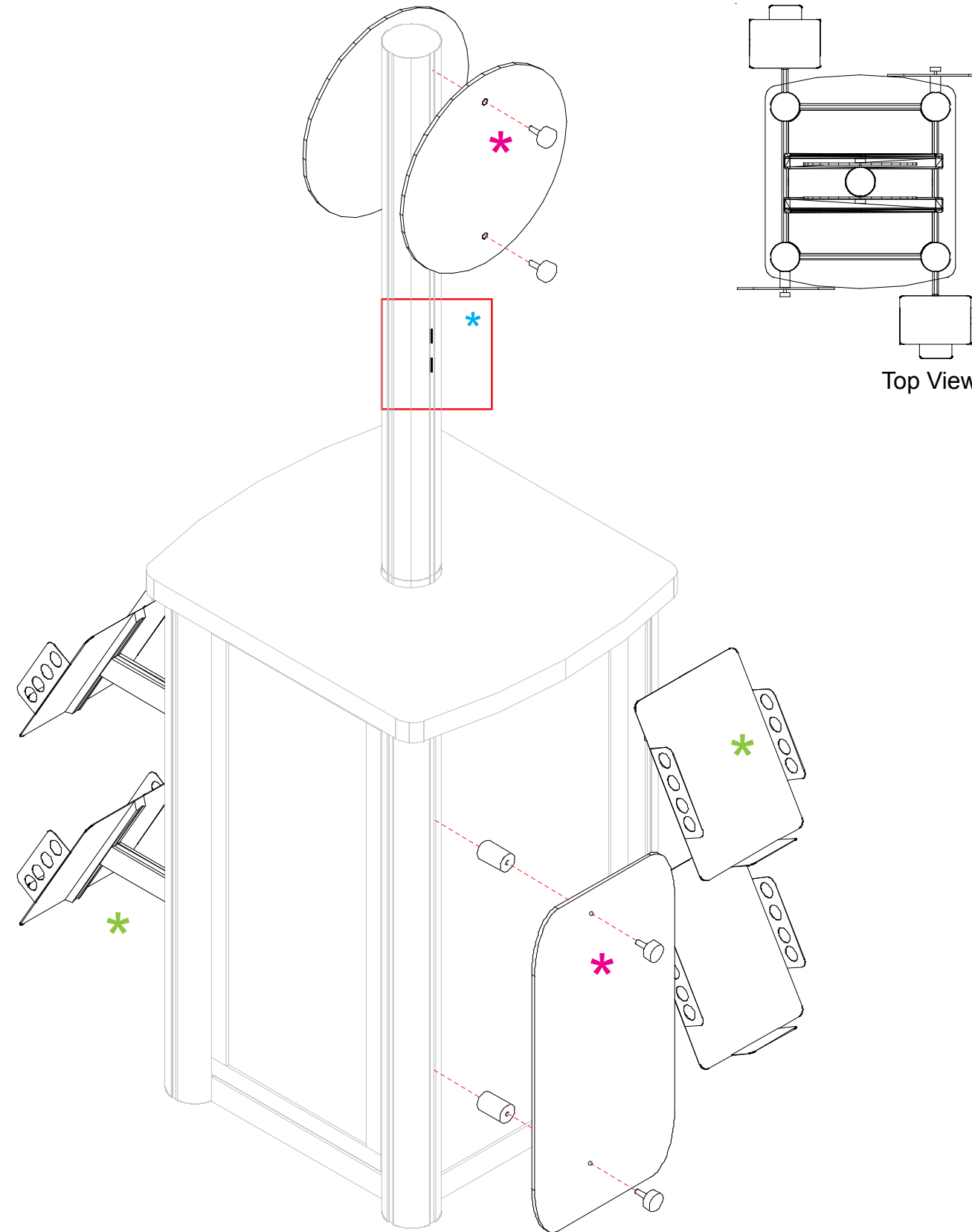

*** Monitor Mount Attachment**

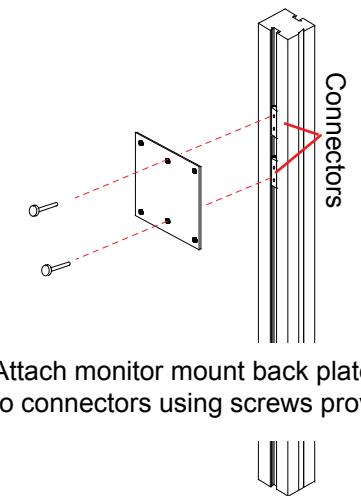

Attach monitor mount back plate to connectors using screws provided.

WHEN DISASSEMBLING ALUMINUM EXTRUSION, TIGHTEN ALL SETSCREWS AND LOCKS TO PREVENT LOSS DURING SHIPPING

Top View of each Level

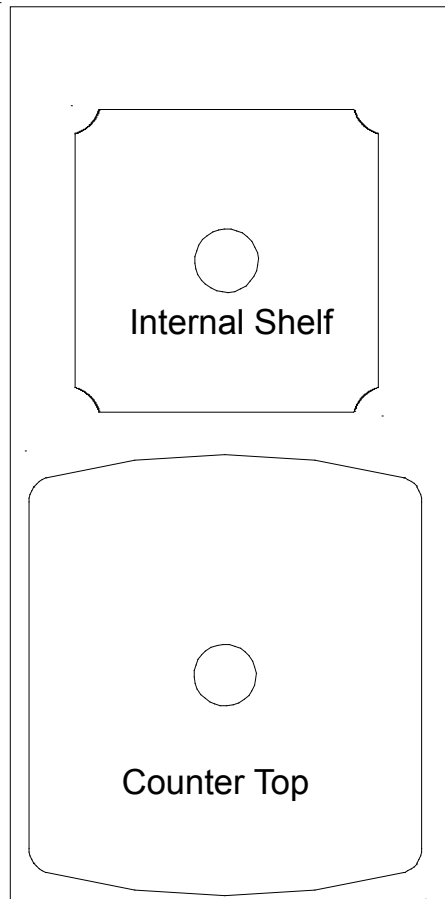

Layer 1

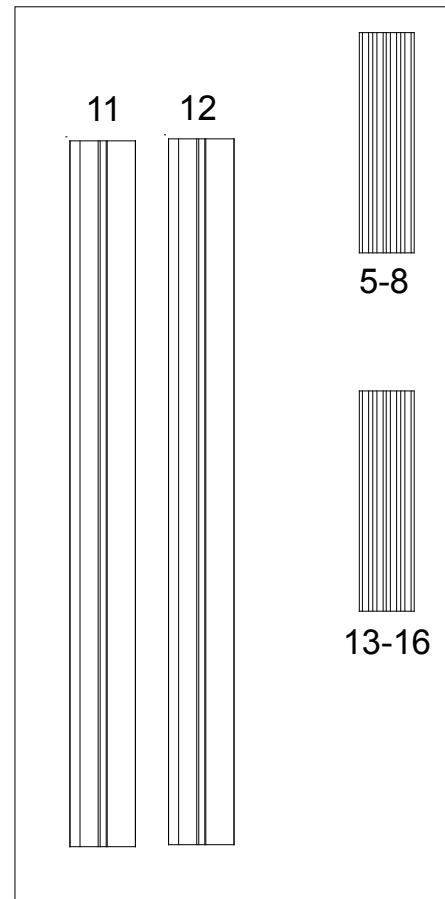

Layer 2

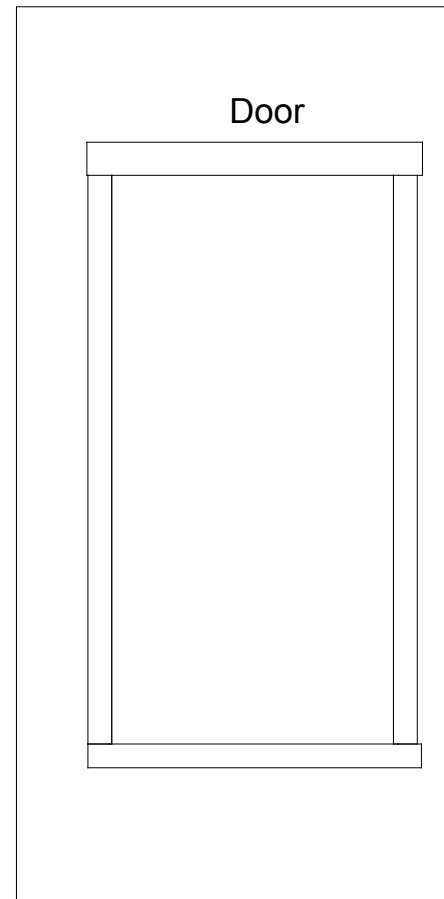

Layer 3

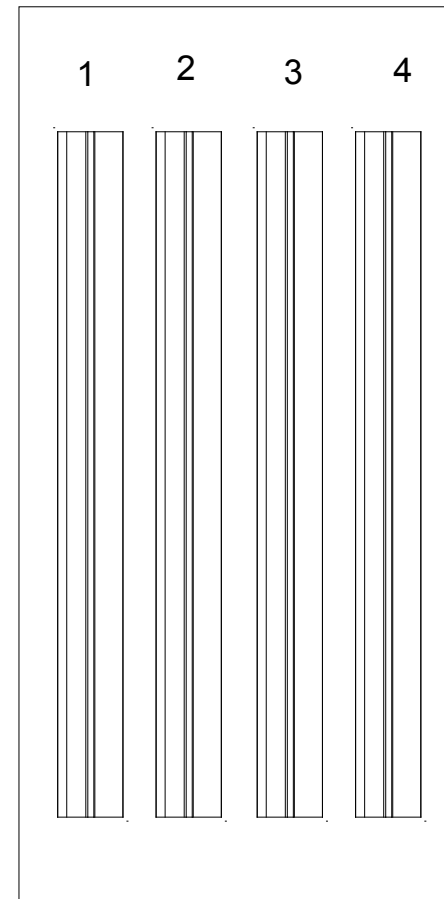

Layer 4

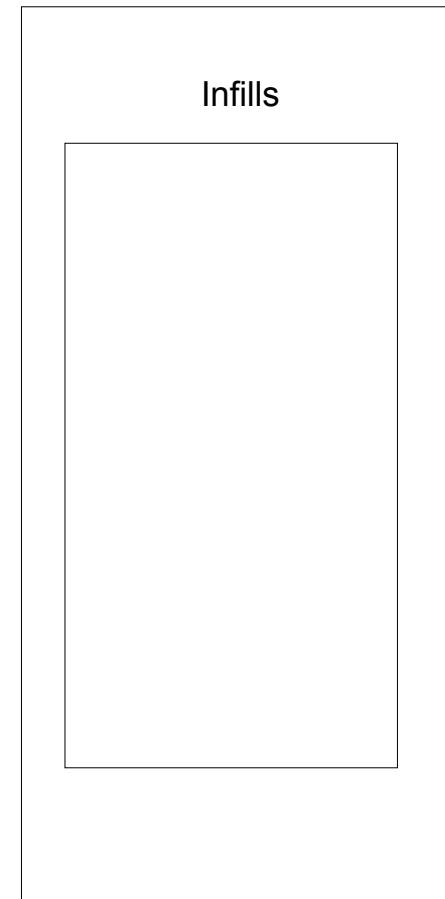

Layer 5

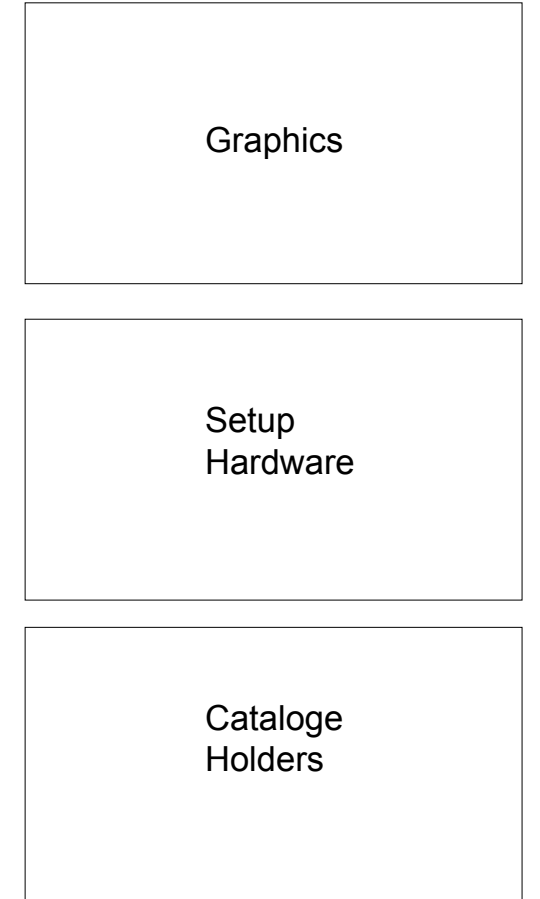

WHEN DISASSEMBLING ALUMINUM EXTRUSION, TIGHTEN ALL SETSCREWS AND LOCKS TO PREVENT LOSS DURING SHIPPING