

WHEN DISASSEMBLING ALUMINUM EXTRUSION, TIGHTEN ALL SETSCREWS AND LOCKS TO PREVENT LOSS DURING SHIPPING

visionary™ IDESIGNS

Using Your Setup Instructions

The Visionary Designs Setup Instructions are created specifically for your configuration. They are laid out sequentially, including an exploded view of the entire display, and then a logical series of detailed steps to assemble the main structure and components. We encourage you to study the instructions **before** attempting to assemble your exhibit.

Each page reminds you to tighten the setscrews after disassembling your exhibit to prevent loss of the locks and setscrews (see below in RED). This is **VERY IMPORTANT**.

Cleaning and Packing Your Display

- 1) Use care when cleaning aluminum extrusion or acrylic inserts. Use only non-abrasive cleaners.
- 2) When cleaning laminate inserts or countertops, use mild cleansers and a soft material such as cotton.
- 3) Keep all display components away from extreme heat and long exposure to sunlight to avoid warping and fading.
- 4) Retain all packing material. It will make re-packing much easier and will reduce the likelihood of shipping damage.



The Tool

Most Visionary Designs exhibits can be assembled with the supplied Hex Key Tool. Occasionally, a flat head screwdriver may be required.



Typical Connection

Most horizontal extrusion connections have a patented expandable lock. This lock inserts into the groove of an opposing extrusion. Tightening the lock with the Hex Key Tool expands the lock and creates a strong positive connection.



Typical Connection (cont'd)

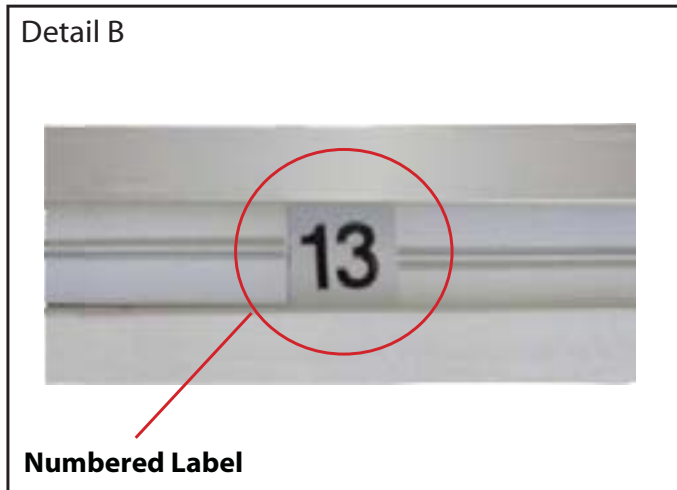

Detail B

Numbered Label

Each extrusion contains a numbered label which corresponds with setup instructions. The label is located within a groove of the extrusion (when possible). With Visionary Designs the labels contain Black numbers unless otherwise specified.



Detail C

Horizontal Inline Connection (remove only one setscrew)

Remove only (1) setscrew when disassembling. Replace setscrew in extrusion after assembling it. Before packing, replace setscrew in extrusion to avoid losing it.

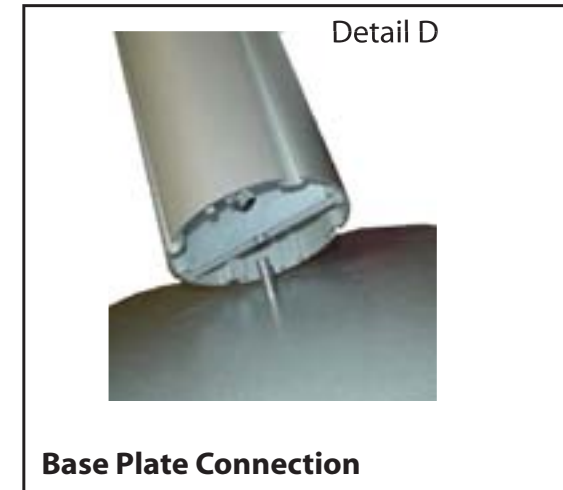

Detail D

Base Plate Connection

Attach base plate to round or square vertical extrusion using the bolt provided. Be careful not to strip the threads.

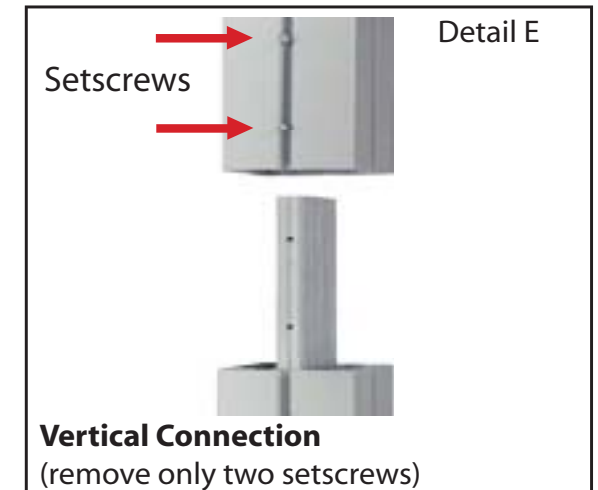

Detail E

Vertical Connection
(remove only two setscrews)

When vertical extrusions are packed in portable cases rather than crates or tubs, they must be broken down into smaller sections which then require assembly.

Remove only (2) setscrews when disassembling. Replace setscrews in extrusion after assembling it. Before packing, replace setscrews in extrusion to avoid losing them.

WHEN DISASSEMBLING ALUMINUM EXTRUSION, TIGHTEN ALL SETSCREWS AND LOCKS TO PREVENT LOSS DURING SHIPPING

Part	Qty	Description
1	3	Base Plate
2	1	4271 Lower Square Vertical Extrusion
3	1	4271 Upper Square Vertical Extrusion
4a	1	4271 Lower Square Vertical Extrusion
4b	1	4271 Upper Square Vertical Extrusion
4a/b	1/1	427a Horizontal Extrusion
4a/b	1/1	427a Horizontal Extrusion

- Steps:**
- 1) Attach vertical extrusions (2) and (3a) to base plate (1).
 - 2) Attach upper vertical extrusions (3) and (3a) to lower extrusions (2) and (2a) using connection bar (4).
 - 3) Connect horizontal extrusions (4a) to (4) and (4b) to (4a) together using connection bar (4).
 - 4) Attach horizontal accessories (4a and 4b) between vertical assemblies as shown.
 - 5) Apply graphics to back of assembled backwall.
 - 6) Attach light to top of assembled backwall.

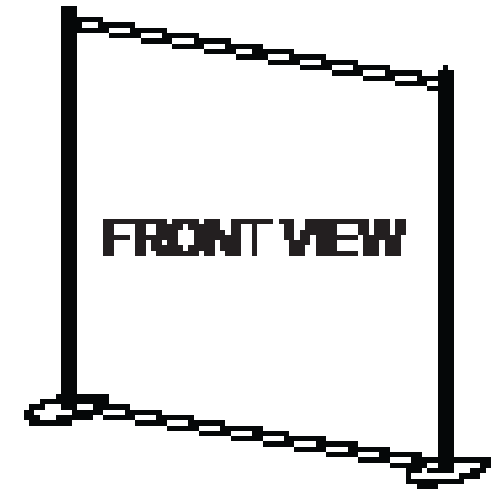

NOTE: Indicated location of hole on horizontal extrusion.



Turn front extrusion to right side lock. Do not over tighten screws.

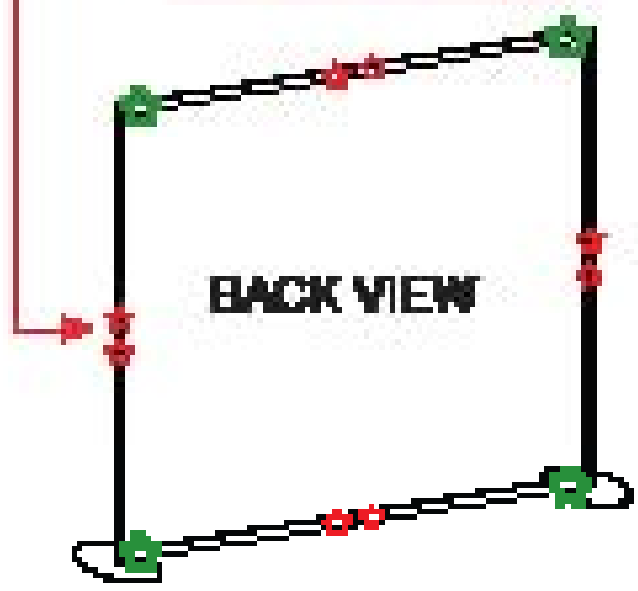
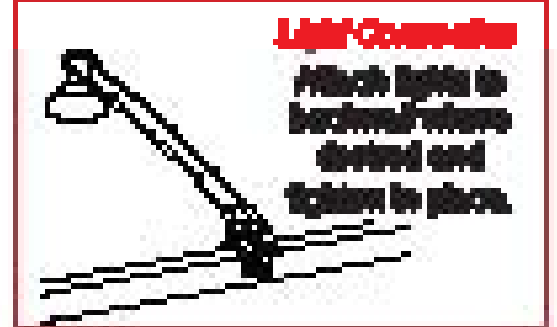
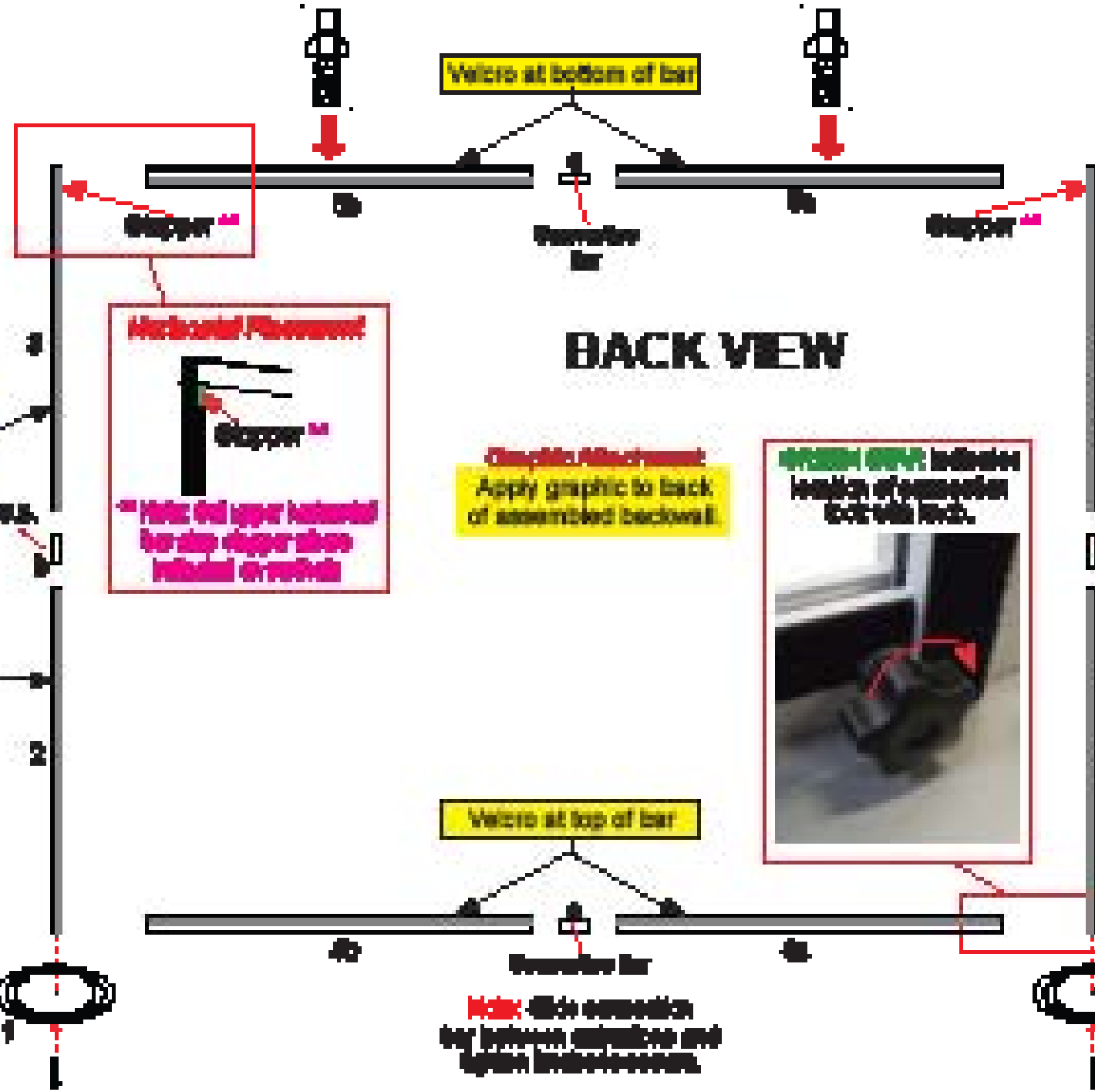

WHEN DISASSEMBLING ALUMINUM EXTRUSION, TIGHTEN ALL SETSCREWS AND LOCKS TO PREVENT LOSS DURING SHIPPING



Using Your Setup Instructions

The Aero Overhead Sign Setup Instructions are created specifically for your configuration. exploded view of the frame which is sequentially numbered. We encourage you to study it before attempting to assemble your exhibit.

Connections are kept very simple: no tools. Everything assembles with push-button connectors and pre-connected horizontal sections.

Cleaning and Packing Your Display

- 1) Use care when cleaning aluminum extrusion or acrylic inserts. Use only non-abrasive cleaner.
- 2) Retain all packing material. It will make re-packing much easier and will reduce the likelihood of shipping damage.

Steps:

- 1) Connect canopy pieces together as shown.
- 2) Apply pillow case graphic to assembled canopy

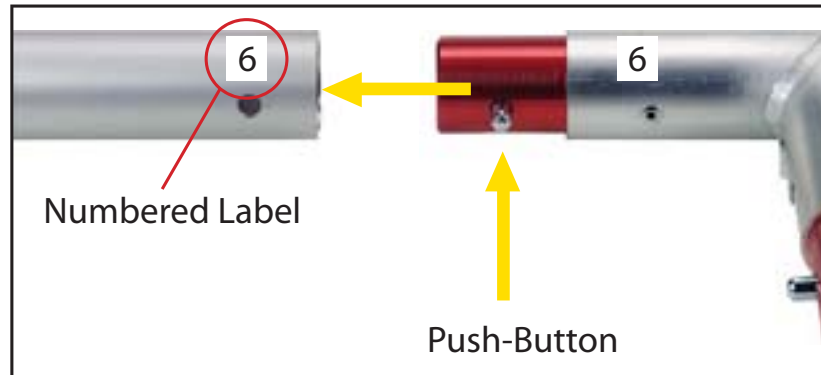
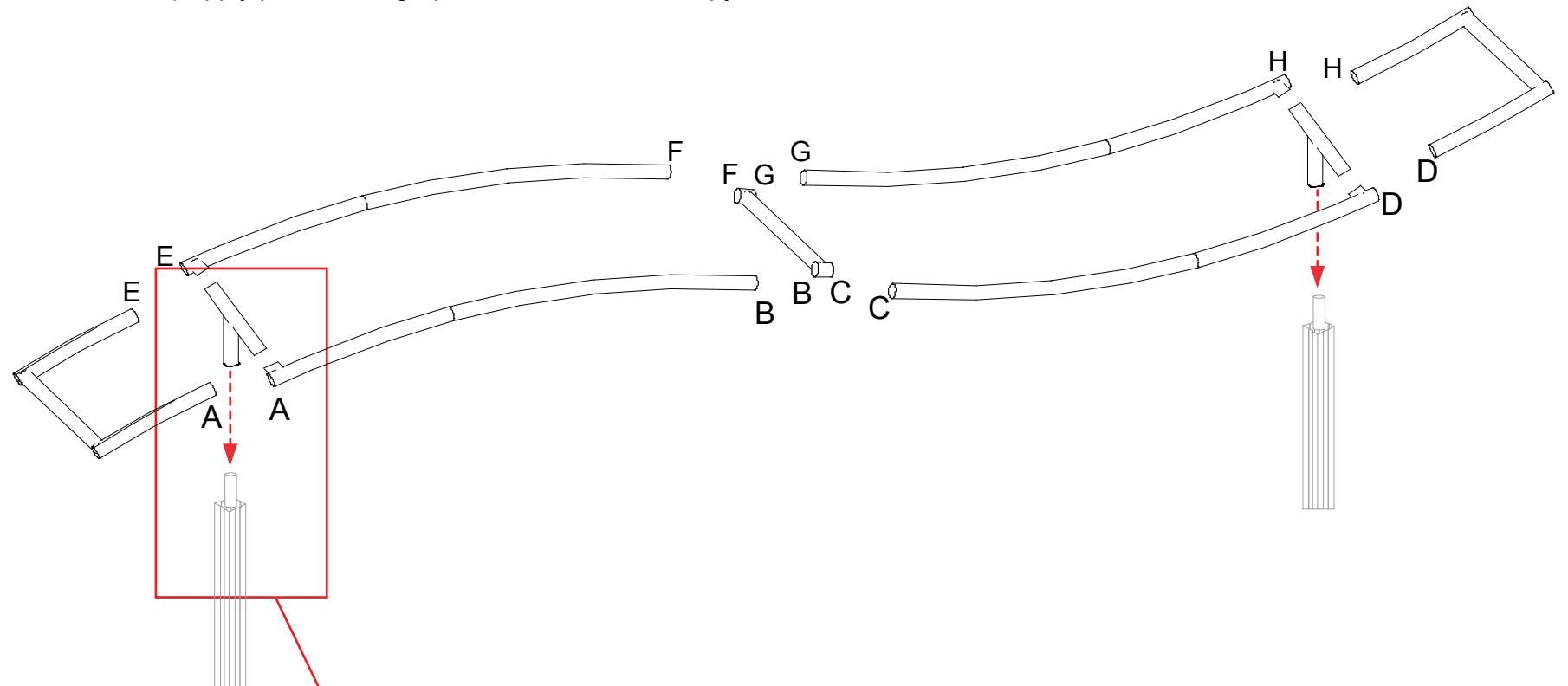

Connections are made by holding the button down and sliding the red tube into opposing tube until the connection is made. To disassemble push button and pull or twist extrusions apart.

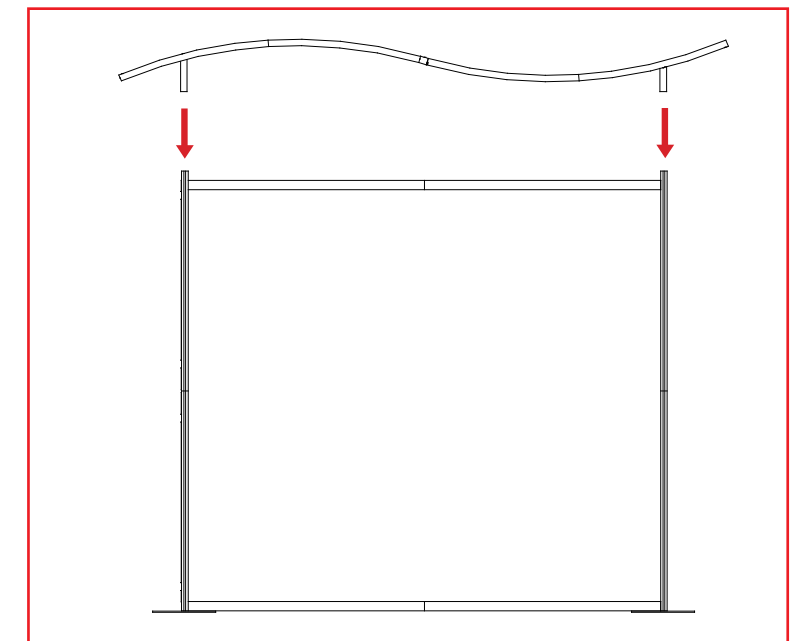
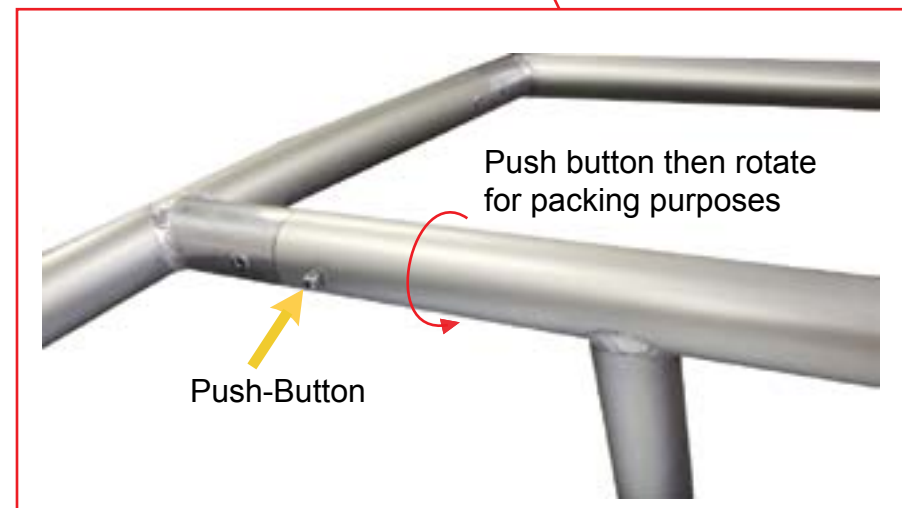
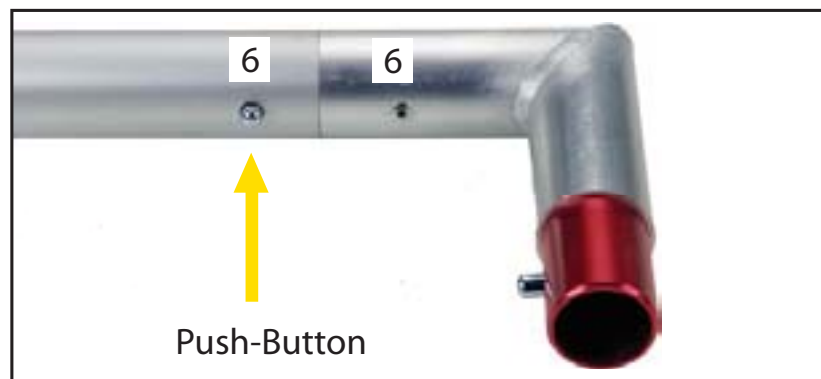

WHEN DISASSEMBLING ALUMINUM EXTRUSION, TIGHTEN ALL SETSCREWS AND LOCKS TO PREVENT LOSS DURING SHIPPING

866.652.2100

Item	Qty.	Description
1	1	38" h Vertical Extrusion
2	1	38" h Vertical Extrusion w/ Door Stopper
3	1	38" h Vertical Extrusion w/ Hinges
4	1	38" h Vertical Extrusion
5	4	13.355" w Horizontal Extrusion
6	2	21.835" w Horizontal Extrusion
7	2	21.888" w Curved Horizontal Extrusion

Steps:

- 1) Attach horizontal extrusions [5, 6 and 7] between vertical extrusions [1, 2, 3 and 4].
- 2) Place inserts and door between vertical extrusions as shown.
- 3) Attach horizontal extrusions [5, 6 and 7] between vertical extrusions [1, 2, 3 and 4] and atop inserts and door.
- 4) Velcro shelf supports to inside of assembled base.
- 5) Place internal shelf atop supports.
- 6) Set counter top on assembled pedestal as shown.

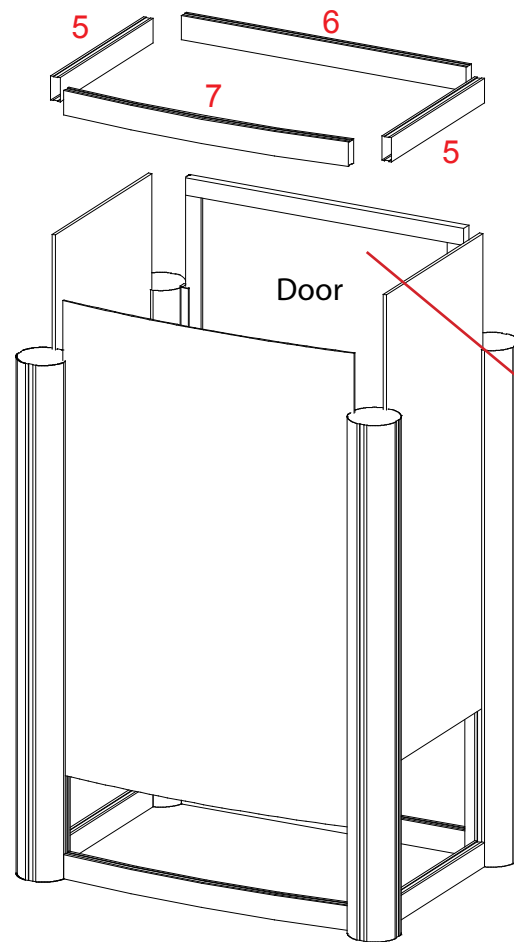
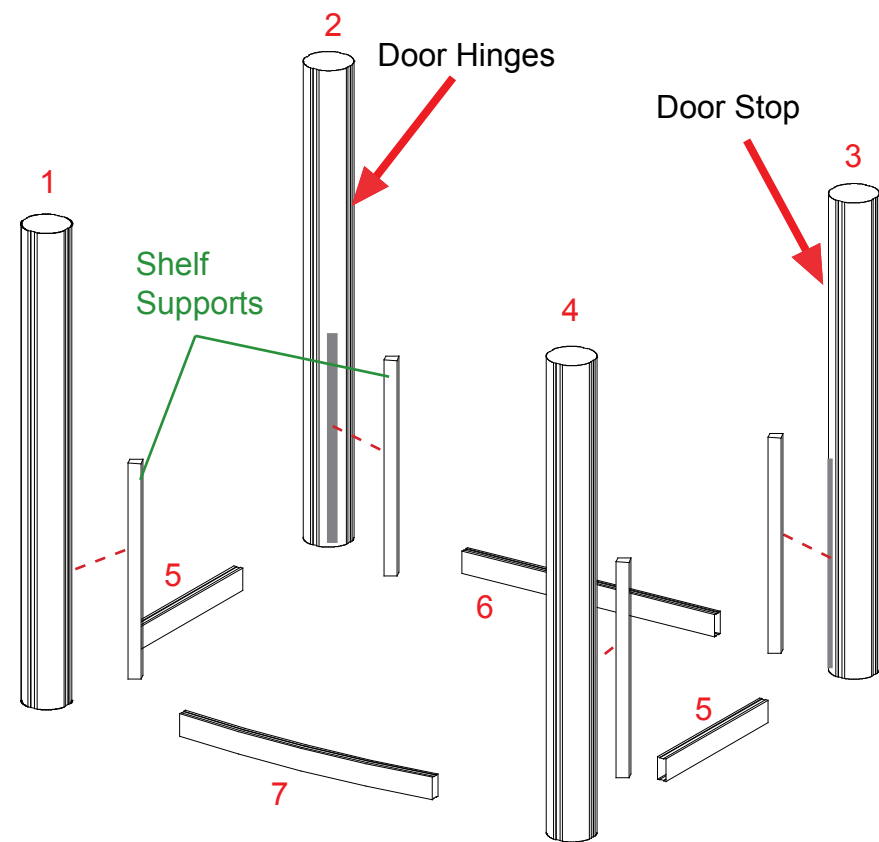

Door Attachment

Slide pin into hinge attached to vertical.
Slide door hinge atop pin.

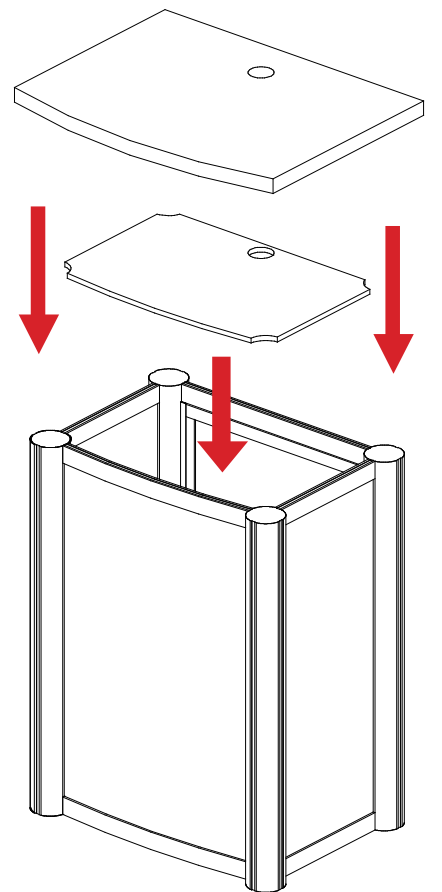
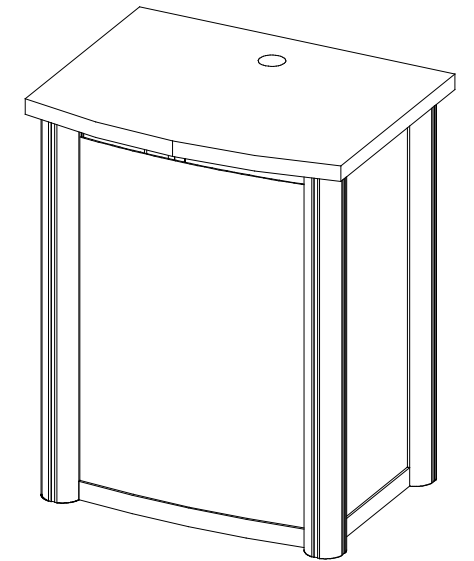

WHEN DISASSEMBLING ALUMINUM EXTRUSION, TIGHTEN ALL SETSCREWS AND LOCKS TO PREVENT LOSS DURING SHIPPING

Top View of Each Level

Backwall Components

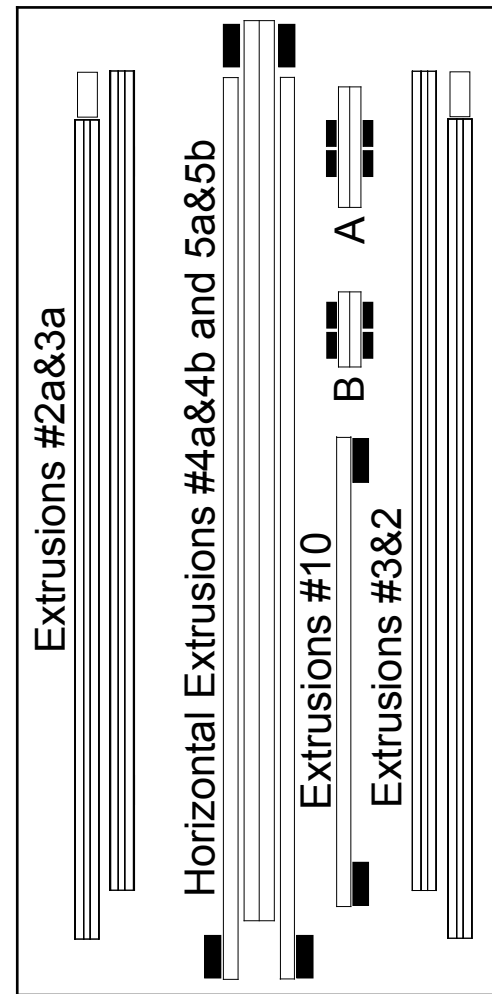

Level 1

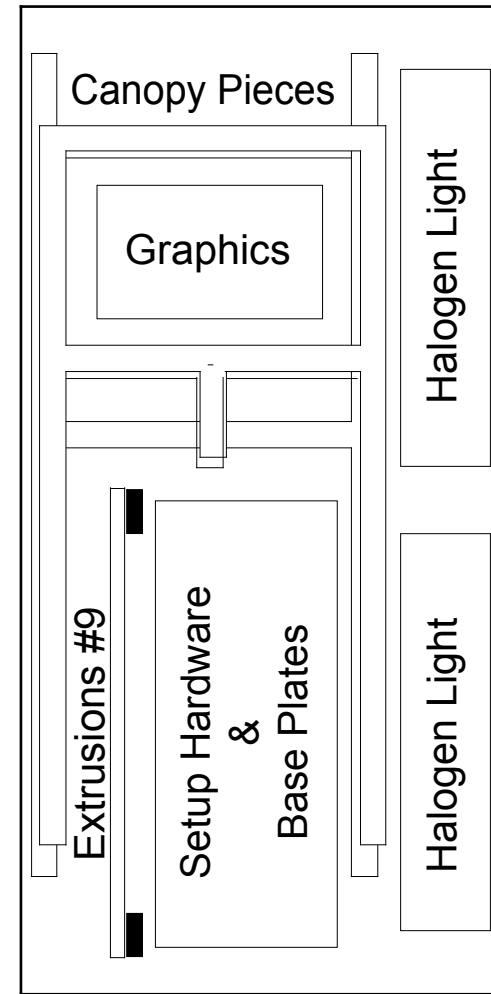

Level 2

WHEN DISASSEMBLING ALUMINUM EXTRUSION, TIGHTEN ALL SETSCREWS AND LOCKS TO PREVENT LOSS DURING SHIPPING

Top View of each Level

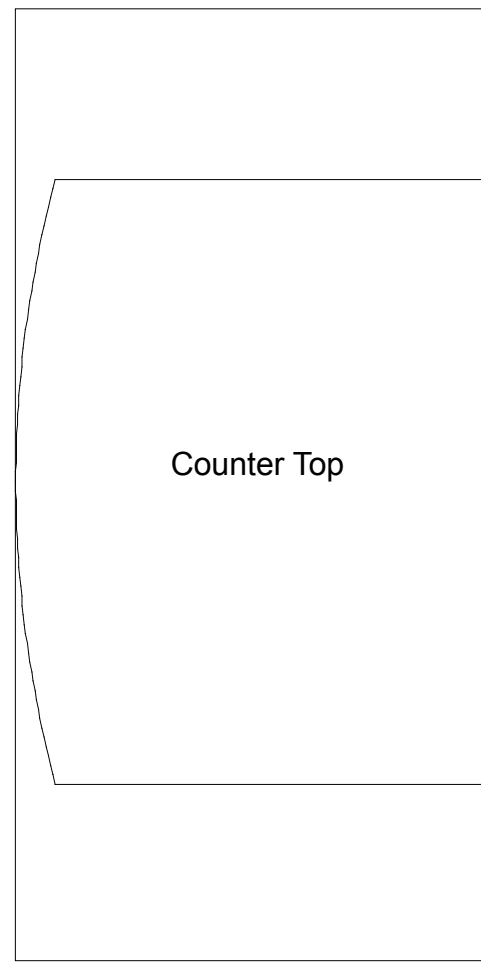

Level 1 [Bottom]

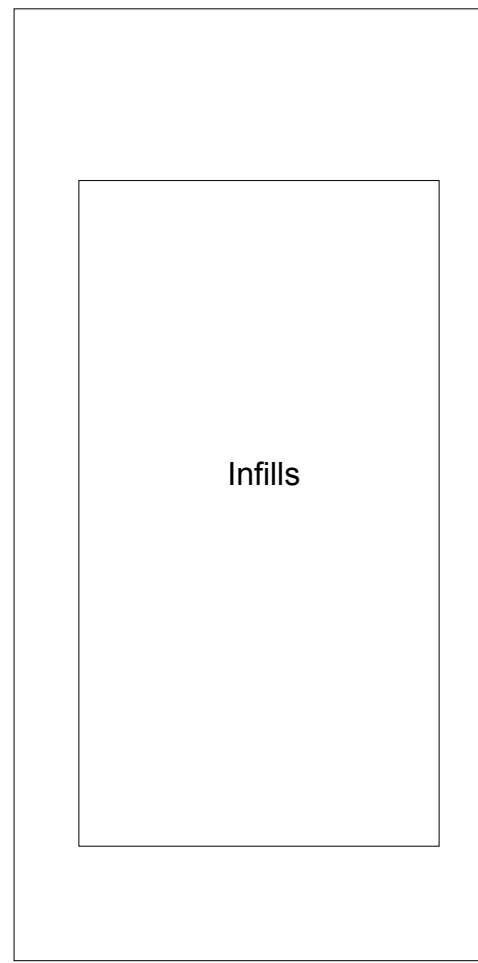

Level 2

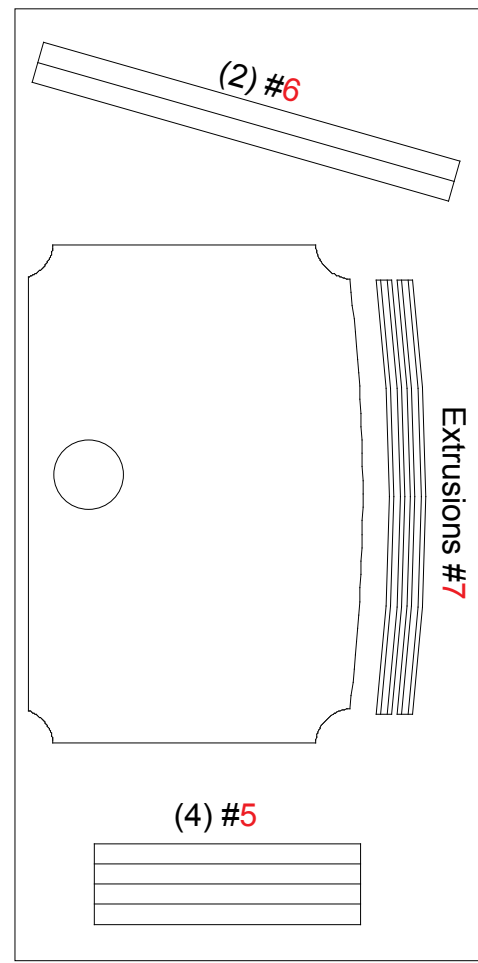

Level 3

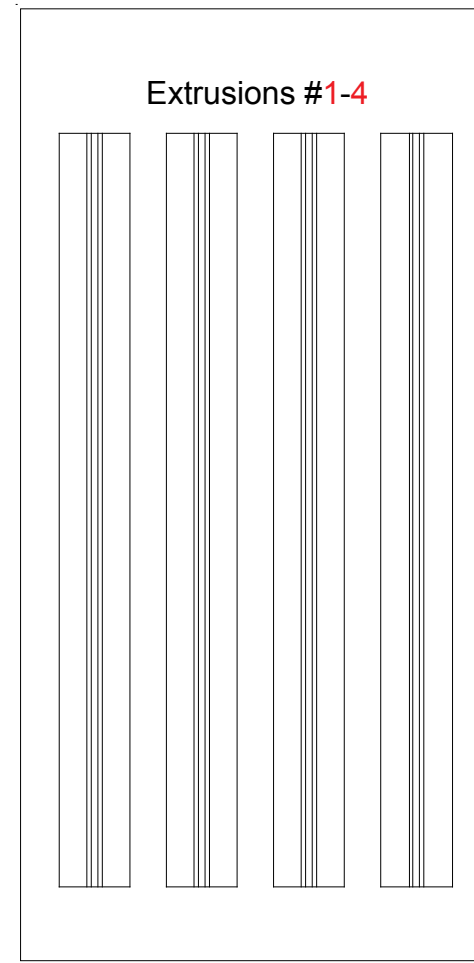

Level 4

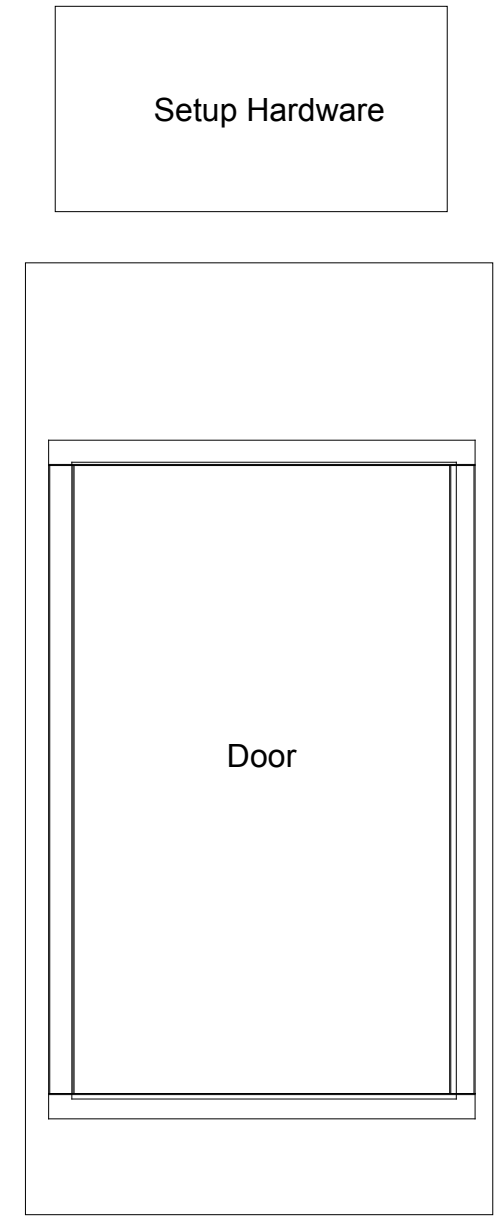

Level 5

Setup Hardware

WHEN DISASSEMBLING ALUMINUM EXTRUSION, TIGHTEN ALL SETSCREWS AND LOCKS TO PREVENT LOSS DURING SHIPPING