

visionary[™]
DESIGNS

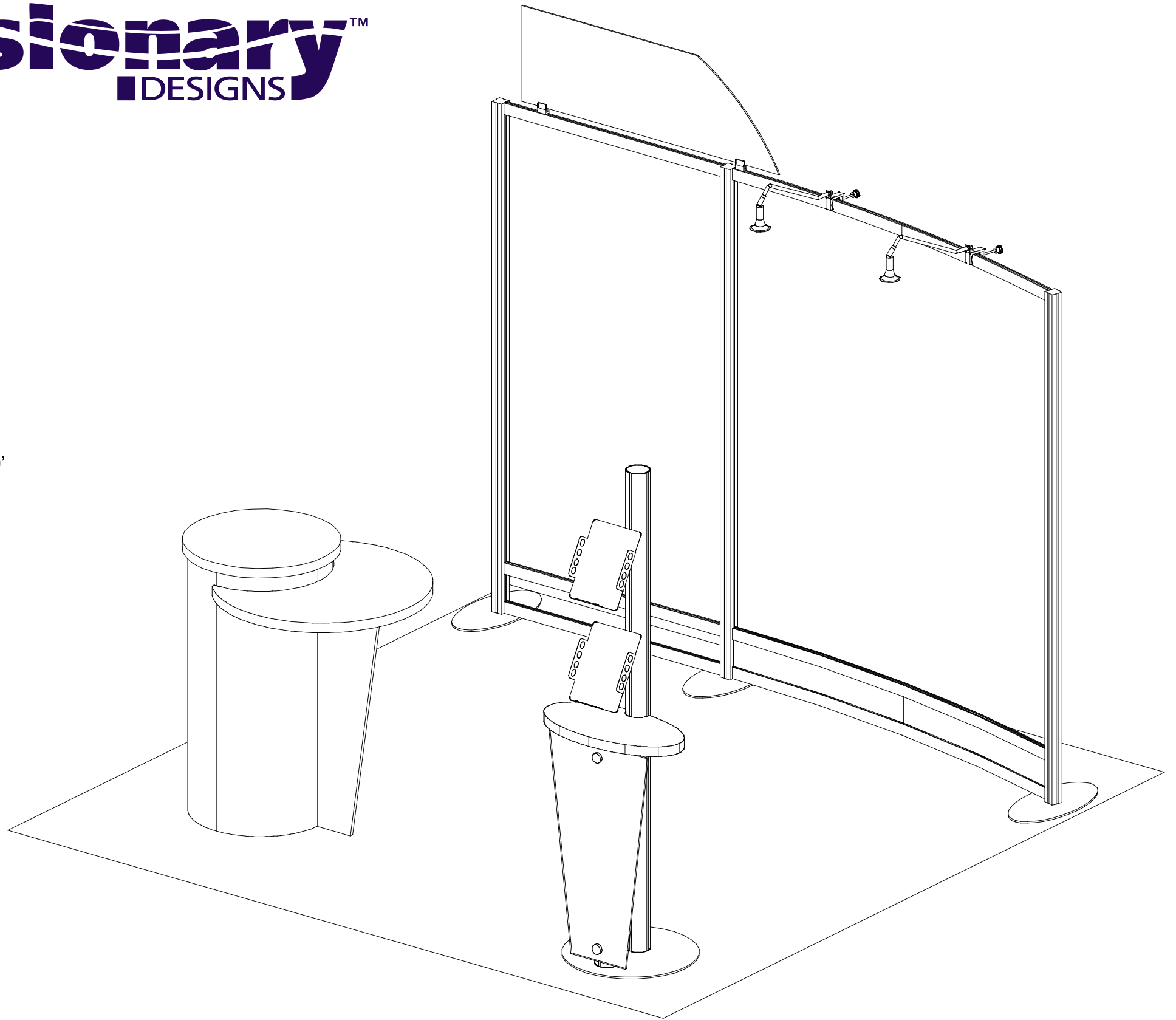
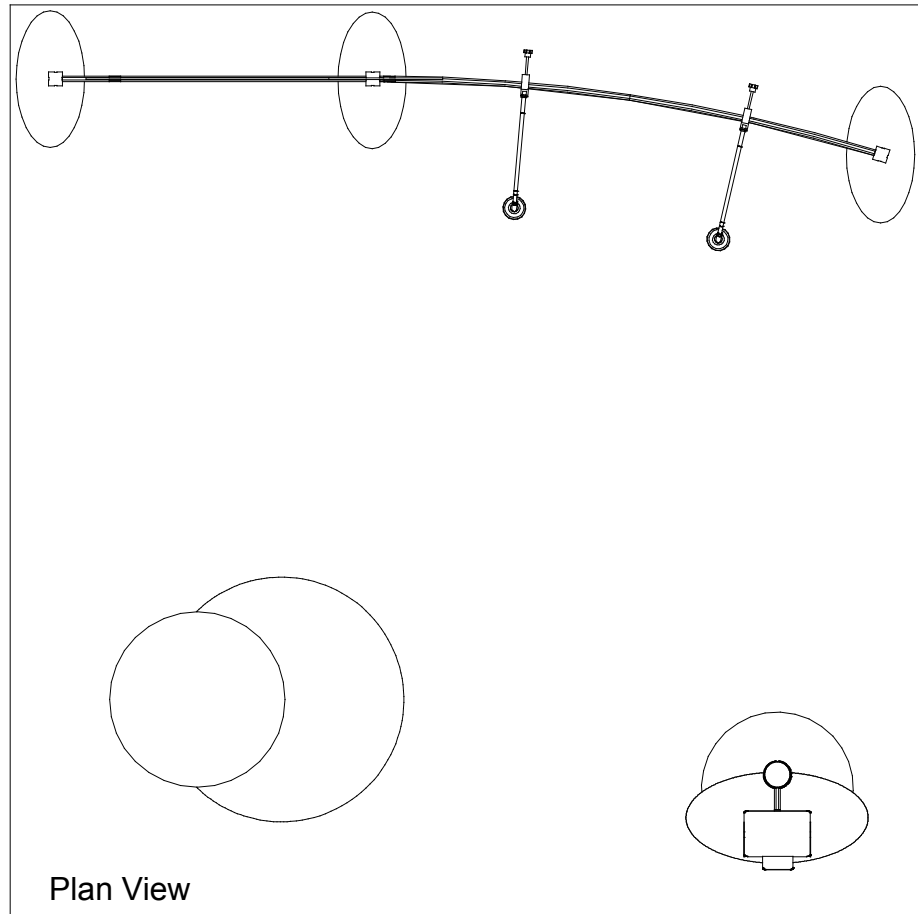

WHEN DISASSEMBLING ALUMINUM EXTRUSION, TIGHTEN ALL SETSCREWS AND LOCKS TO PREVENT LOSS DURING SHIPPING

visionary™ DESIGNS

Using Your Setup Instructions

The Visionary Designs Setup Instructions are created specifically for your configuration. They are laid out sequentially, including an exploded view of the entire display, and then a logical series of detailed steps to assemble the main structure and components. We encourage you to study the instructions **before** attempting to assemble your exhibit.

Each page reminds you to tighten the setscrews after disassembling your exhibit to prevent loss of the locks and setscrews (see below in RED). This is **VERY IMPORTANT**.

Cleaning and Packing Your Display

- 1) Use care when cleaning aluminum extrusion or acrylic inserts. Use only non-abrasive cleaners.
- 2) When cleaning laminate inserts or countertops, use mild cleansers and a soft material such as cotton.
- 3) Keep all display components away from extreme heat and long exposure to sunlight to avoid warping and fading.
- 4) Retain all packing material. It will make re-packing much easier and will reduce the likelihood of shipping damage.



The Tool

Most Visionary Designs exhibits can be assembled with the supplied Hex Key Tool. Occasionally, a flat head screwdriver may be required.



Detail A

Typical Connection



Typical Connection (cont'd)

Most horizontal extrusion connections have a patented expandable lock. This lock inserts into the groove of an opposing extrusion. Tightening the lock with the Hex Key Tool expands the lock and creates a strong positive connection.

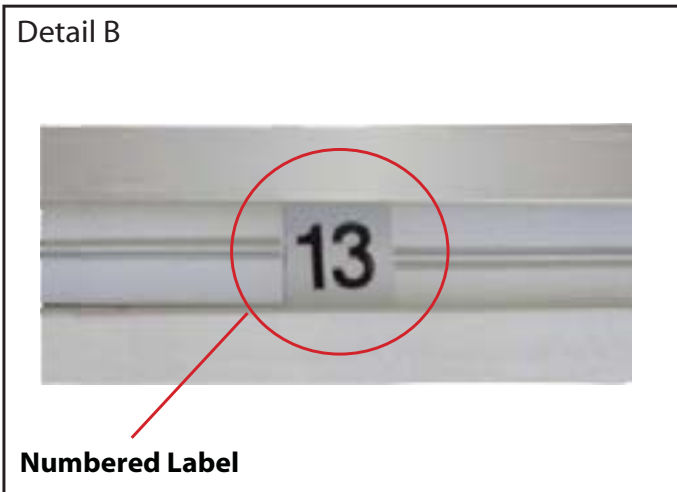

Detail B

Numbered Label

Each extrusion contains a numbered label which corresponds with setup instructions. The label is located within a groove of the extrusion (when possible). With Visionary Designs the labels contain Black numbers unless otherwise specified.



Detail C

Horizontal Inline Connection (remove only one setscrew)

Remove only (1) setscrew when disassembling. Replace setscrew in extrusion after assembling it. Before packing, replace setscrew in extrusion to avoid losing it.

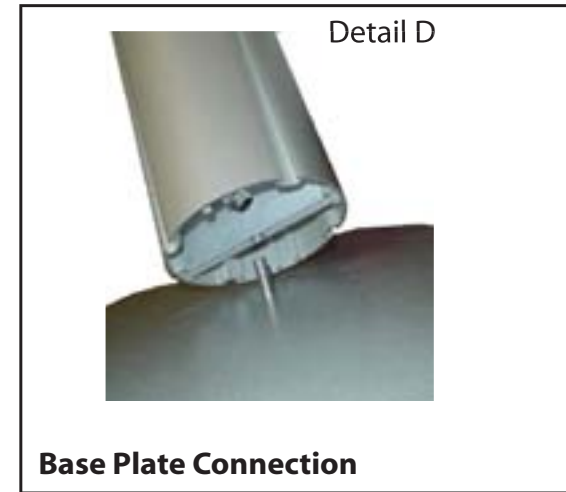

Detail D

Base Plate Connection

Attach base plate to round or square vertical extrusion using the bolt provided. Be careful not to strip the threads.

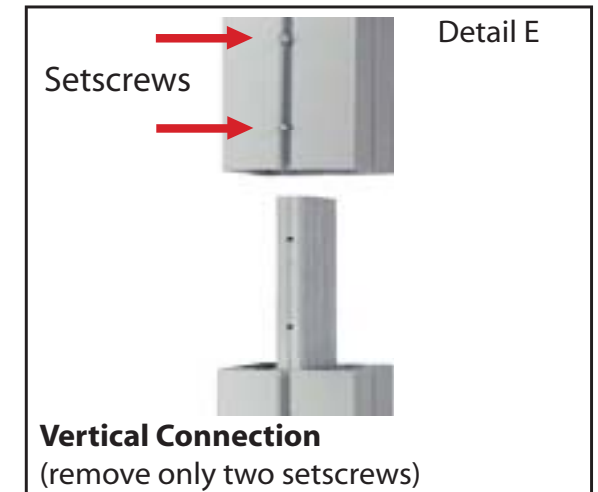

Detail E

Vertical Connection
(remove only two setscrews)

When vertical extrusions are packed in portable cases rather than crates or tubs, they must be broken down into smaller sections which then require assembly.

Remove only (2) setscrews when disassembling. Replace setscrews in extrusion after assembling it. Before packing, replace setscrews in extrusion to avoid losing them.



WHEN DISASSEMBLING ALUMINUM EXTRUSION, TIGHTEN ALL SETSCREWS AND LOCKS TO PREVENT LOSS DURING SHIPPING

Item	Qty.	Description
1	3	Base Plate
2	1	40"h Vertical Extrusion
3	1	40"h Vertical Extrusion
4	1	40"h Vertical Extrusion
5	1	40"h Vertical Extrusion
6	1	40"h Vertical Extrusion
7	1	40"h Vertical Extrusion
8	1	40"w Horizontal Extrusion
9	1	33.151"w Horizontal Curved Extrusion
10	1	33.151"w Horizontal Curved Extrusion
11	1	40"w Horizontal Extrusion
12	1	33.151"w Horizontal Curved Extrusion
13	1	33.151"w Horizontal Curved Extrusion

Steps:

- 1) Attach vertical extrusions [2, 4, & 6] to base plates [1].
- 2) Attach upper vertical extrusions [3, 5, & 7] to lower extrusions [2, 4, & 6].
- 3) Connect horizontal extrusions [9 to 10 & 12 to 13] together.
- 4) Attach horizontal extrusions [8 & 11] and assemblies [9/10 & 12/13] between vertical assemblies as shown.
Note: Leave 5/8" clearance between base plates and lower horizontal extrusions.
- 5) Apply graphic to back of assembled backwall.

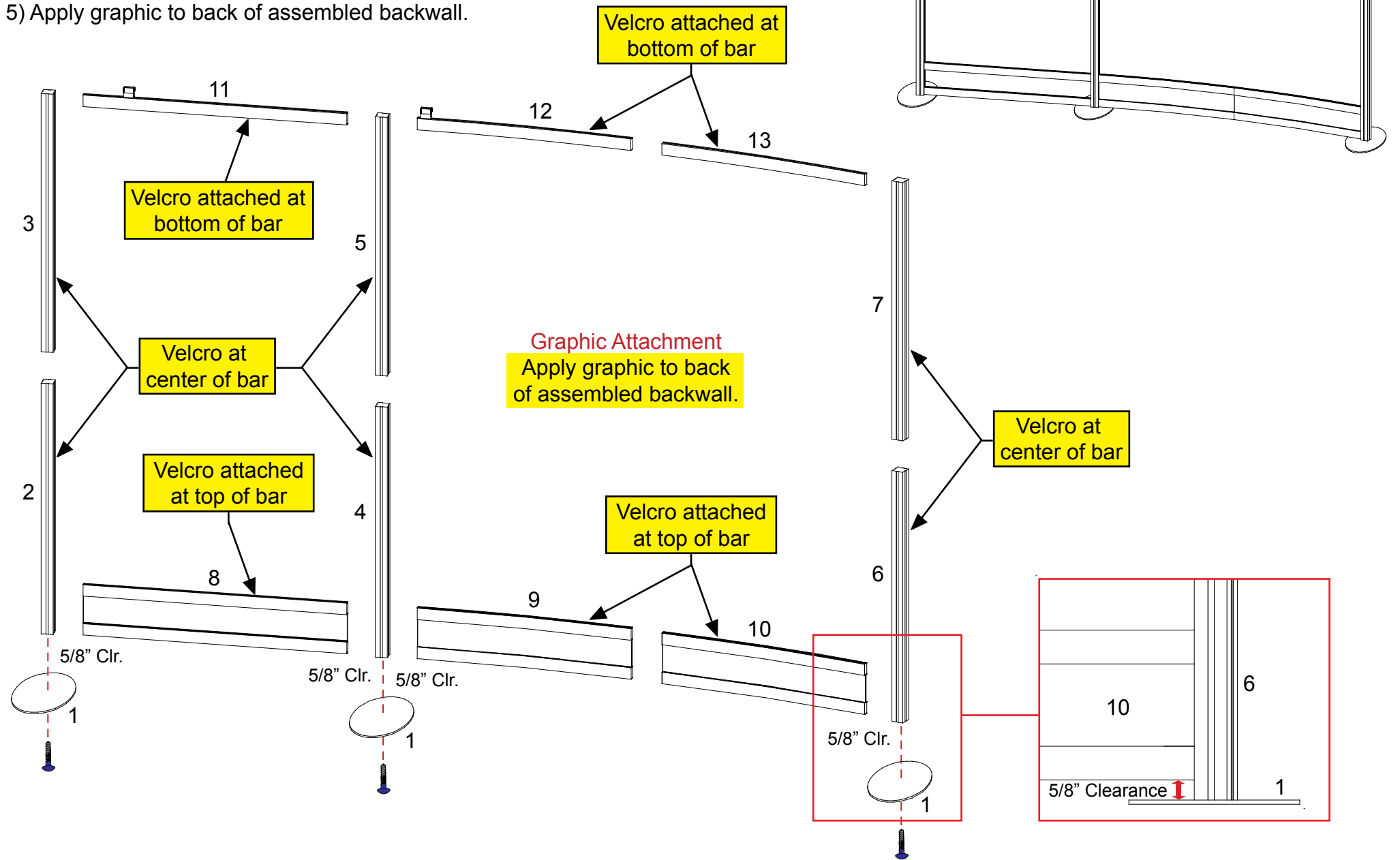

WHEN DISASSEMBLING ALUMINUM EXTRUSION, TIGHTEN ALL SETSCREWS AND LOCKS TO PREVENT LOSS DURING SHIPPING

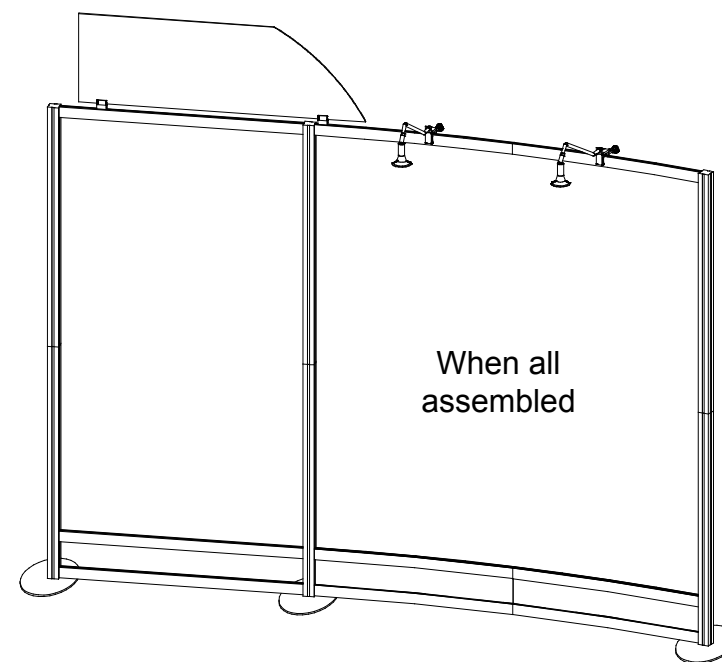
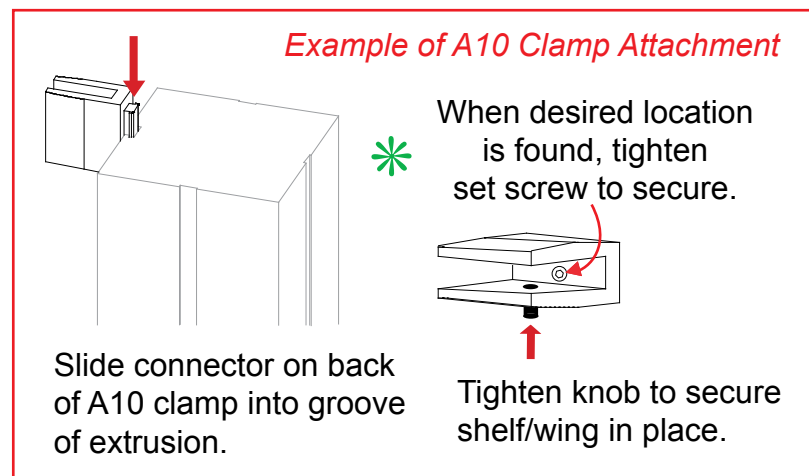

Steps:
1) Attach header graphic, pamphlet trays, and lights to assembled backwall as shown. Refer to details.

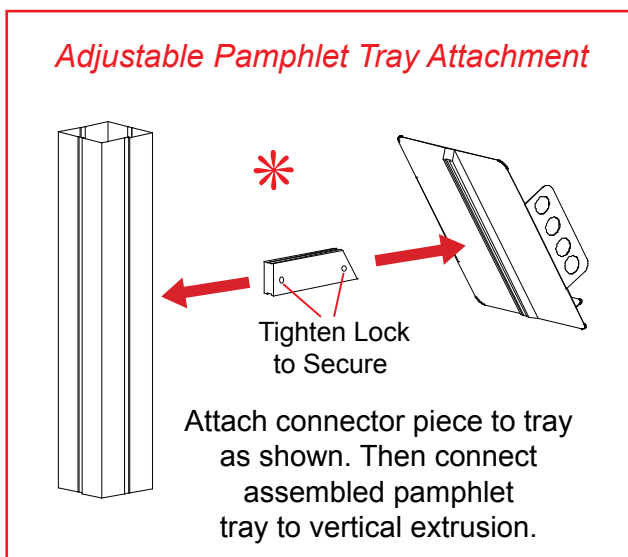
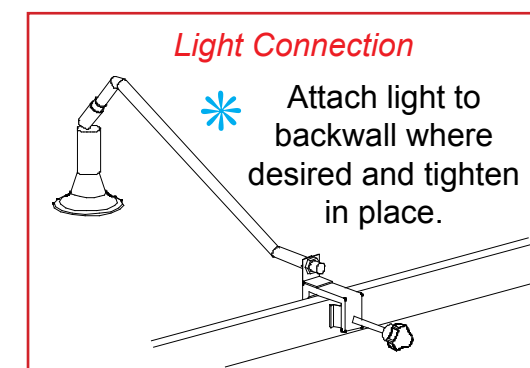
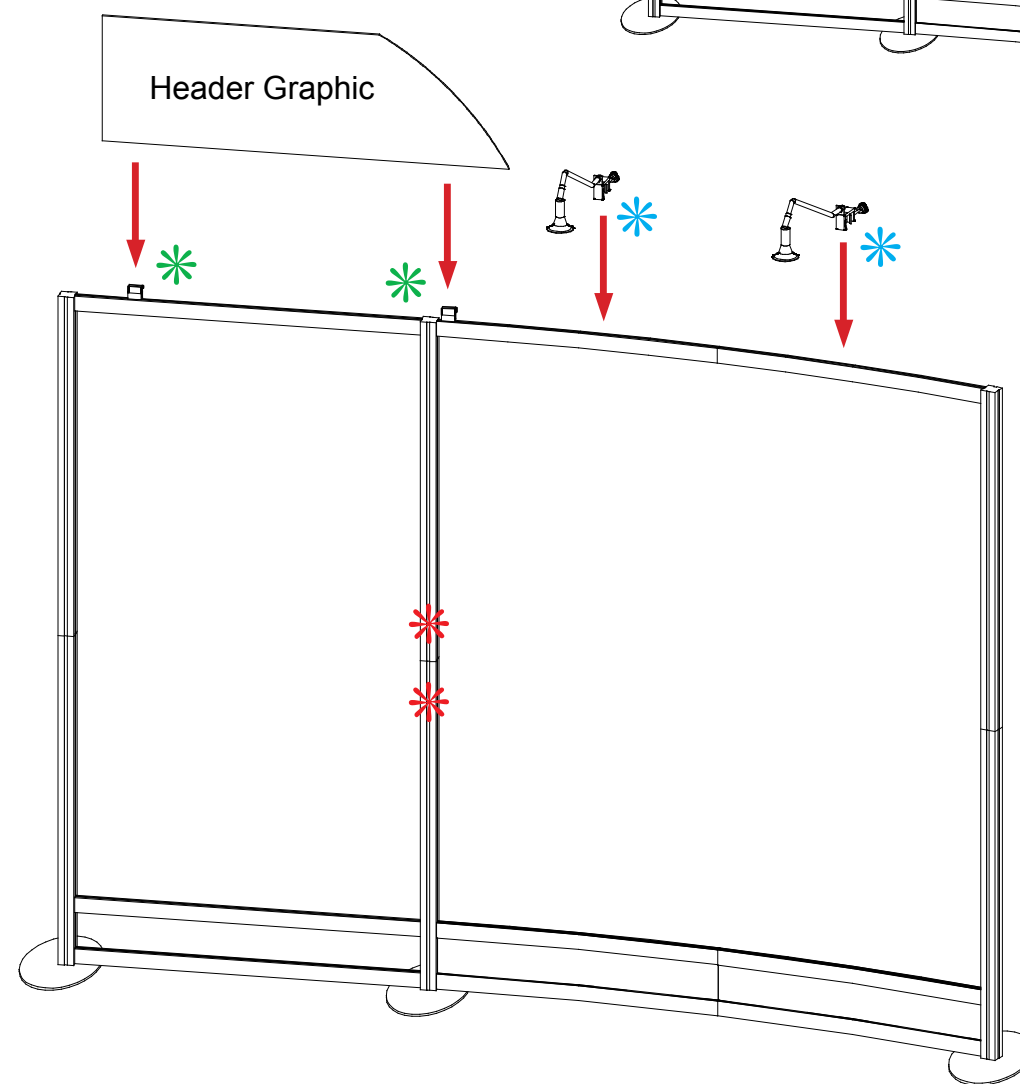

WHEN DISASSEMBLING ALUMINUM EXTRUSION, TIGHTEN ALL SETSCREWS AND LOCKS TO PREVENT LOSS DURING SHIPPING

Item	Qty.	Description
14	1	18"D Round Base Plate
15	1	40"h Lower Round Vertical Extrusion
16	1	40"h Upper Round Vertical Extrusion
17	1	36"h Round Vertical Extrusion

Steps

- 1) Attach vertical extrusions [15 and 17] to base plate [14] as shown.
- 2) Attach upper vertical extrusion [16] atop vertical extrusion [15].
- 3) Attach tapered plex wing to front of vertical extrusion [17] using standoff caps and 16"D round sintra sign to vertical extrusion [16].
- 3) Place and attach counter atop vertical extrusion [17].
- 4) Attach pamphlet tray to vertical [16].

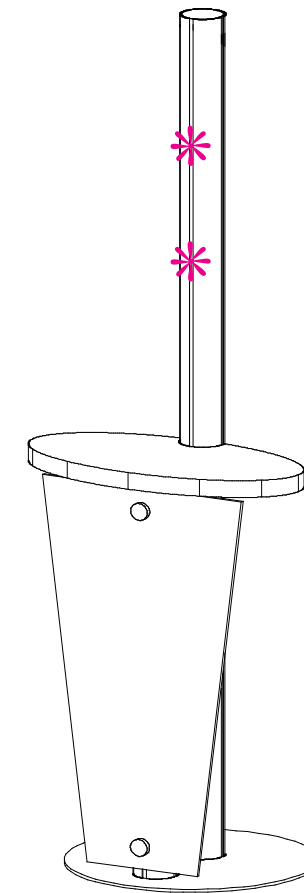
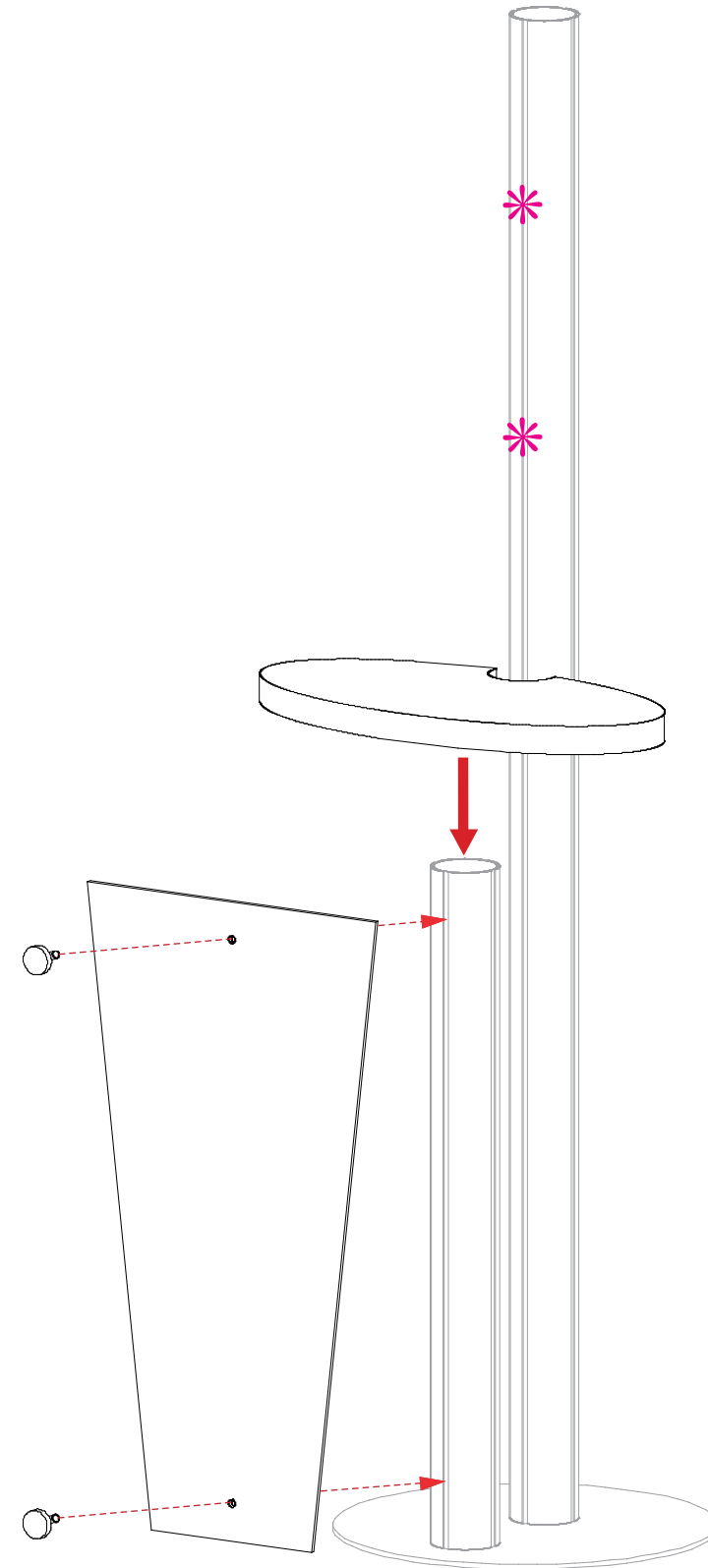
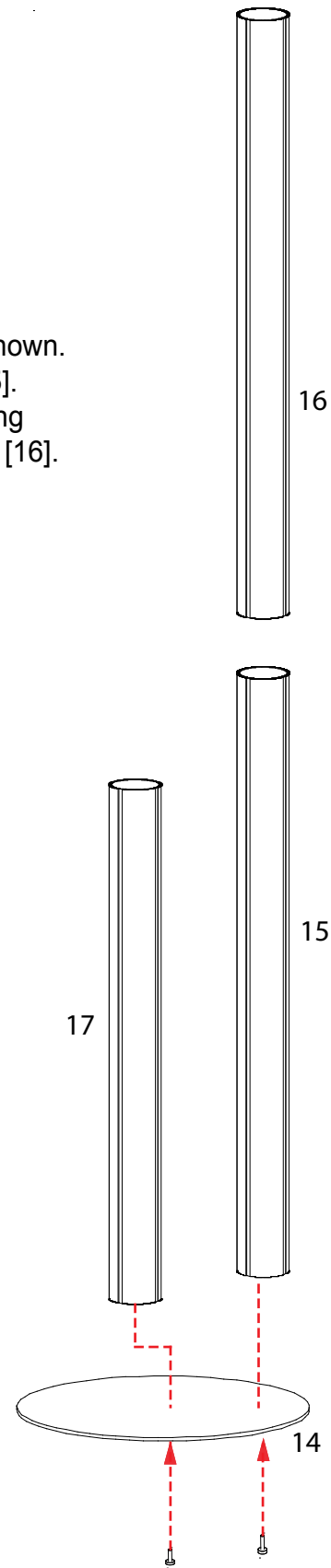
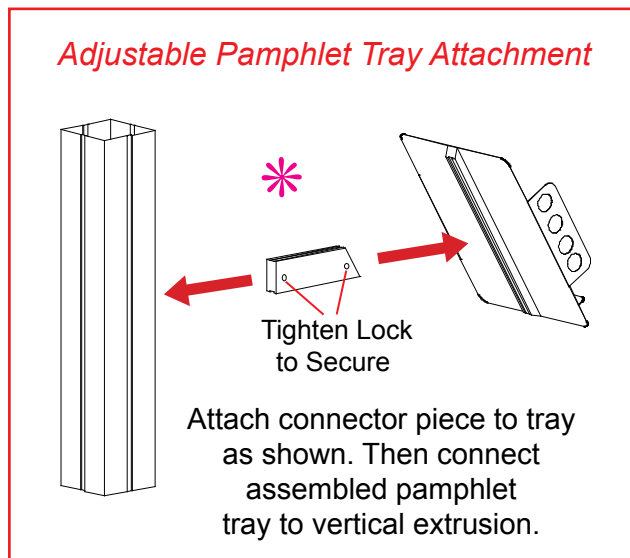

WHEN DISASSEMBLING ALUMINUM EXTRUSION, TIGHTEN ALL SETSCREWS AND LOCKS TO PREVENT LOSS DURING SHIPPING

866.652.2100

Item	Description
1	42”h Curved Panel w/Door
2	42”h Curved Panel
3	42”h Curved Panel
4	42”h Curved Panel w/Velcro
5	38”h Counter Support Panel w/Buttons

Steps:

- 1) Assemble panels in numerical order.
- 2) Attach counter support panel #5 to panel #4 w/velcro.
- 3) Set front counter atop support #5 and thumbscrew sides into panels.
- 4) Set circular counter atop assembled pedestal as shown in illustration.

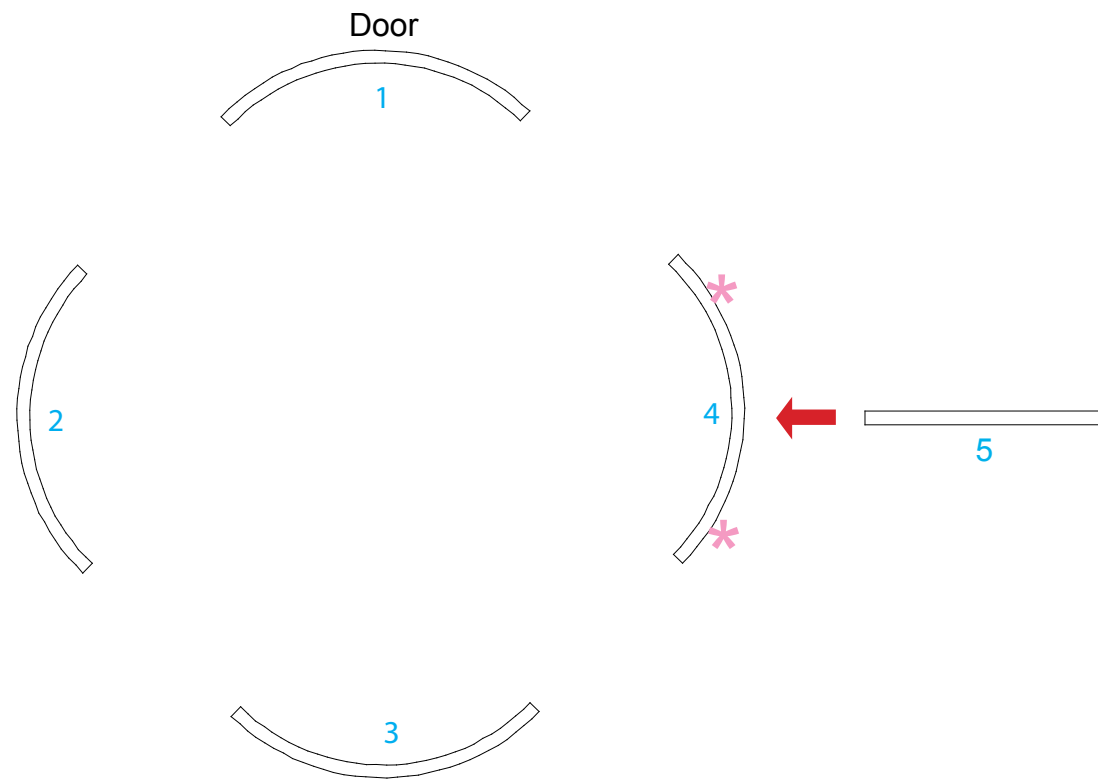

* = Thumbscrew Location

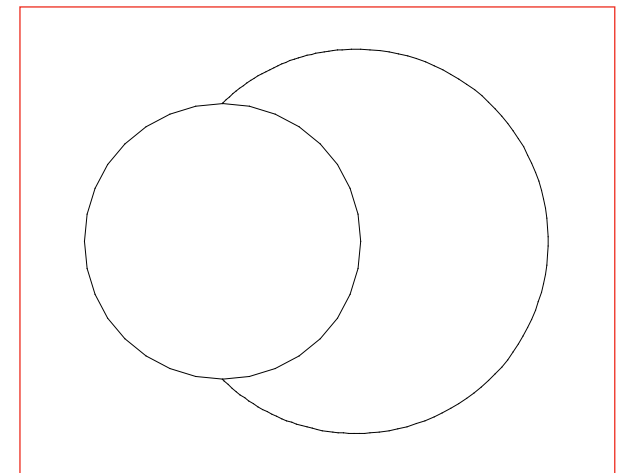
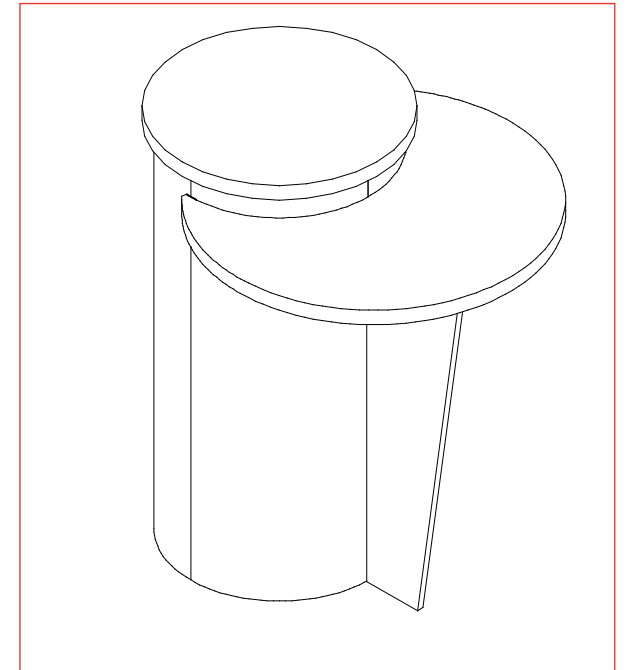
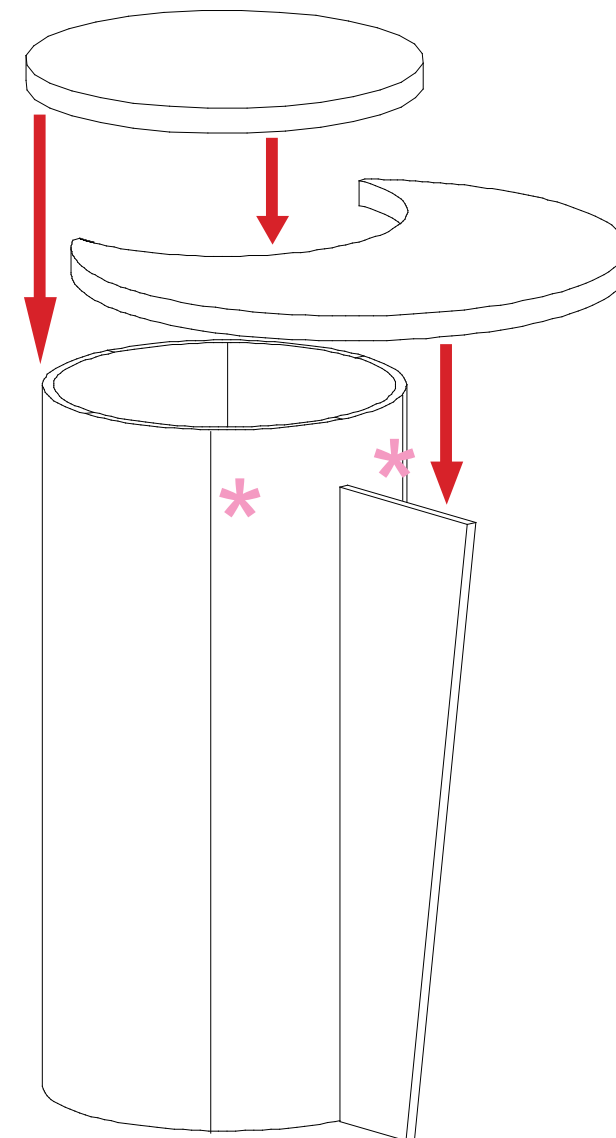

WHEN DISASSEMBLING ALUMINUM EXTRUSION, TIGHTEN ALL SETSCREWS AND LOCKS TO PREVENT LOSS DURING SHIPPING

View of Each Level

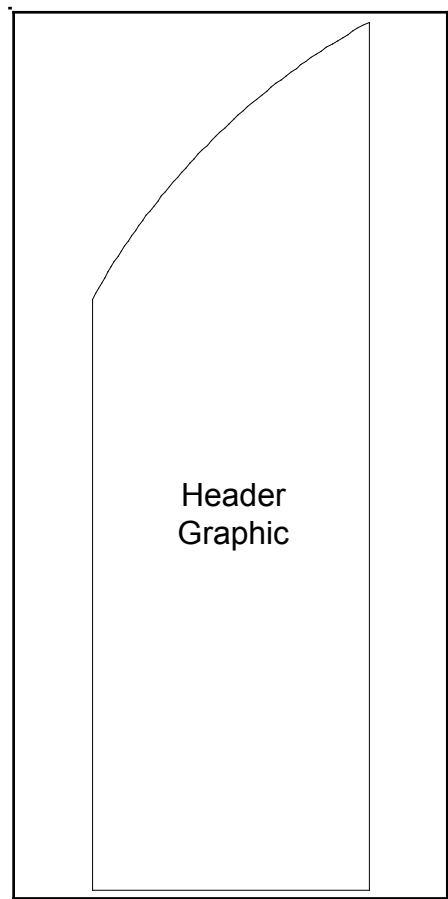

Level 1

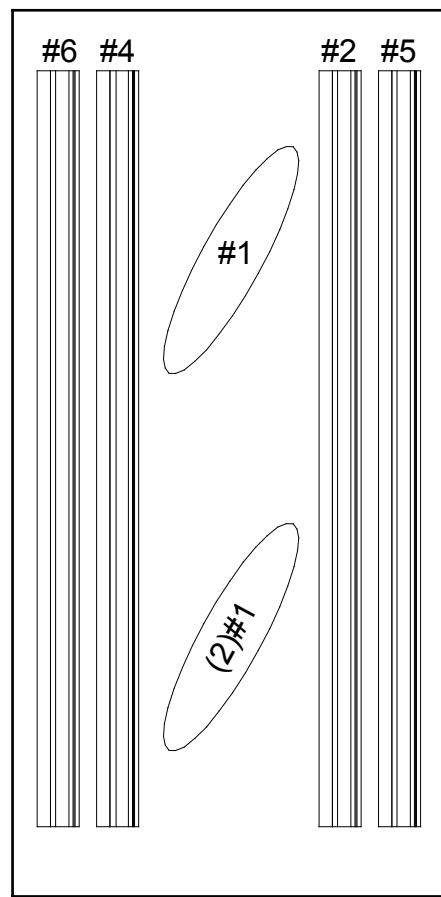

Level 2

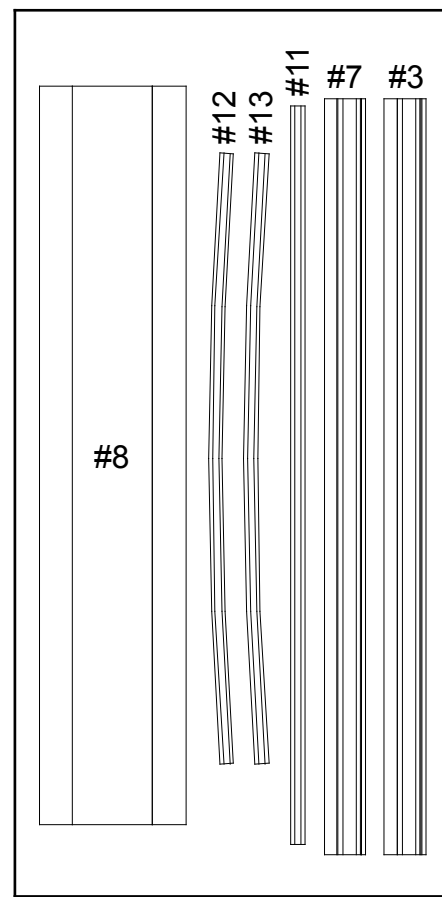

Level 3

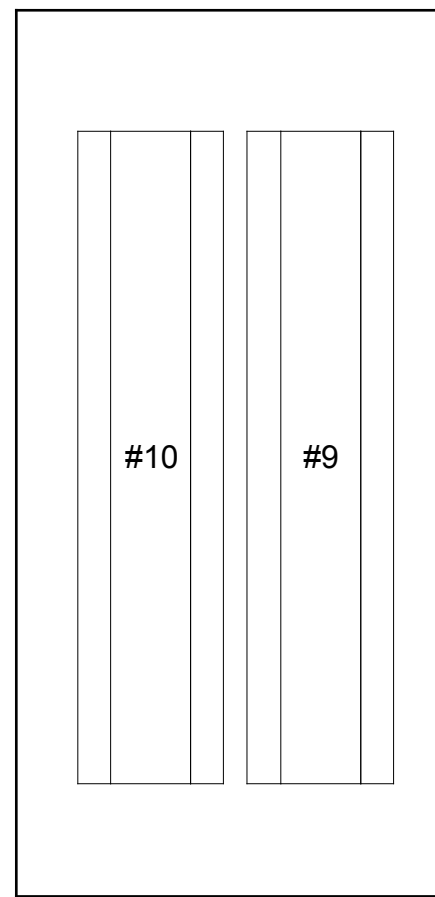

Level 4



WHEN DISASSEMBLING ALUMINUM EXTRUSION, TIGHTEN ALL SETSCREWS AND LOCKS TO PREVENT LOSS DURING SHIPPING

View of Each Level

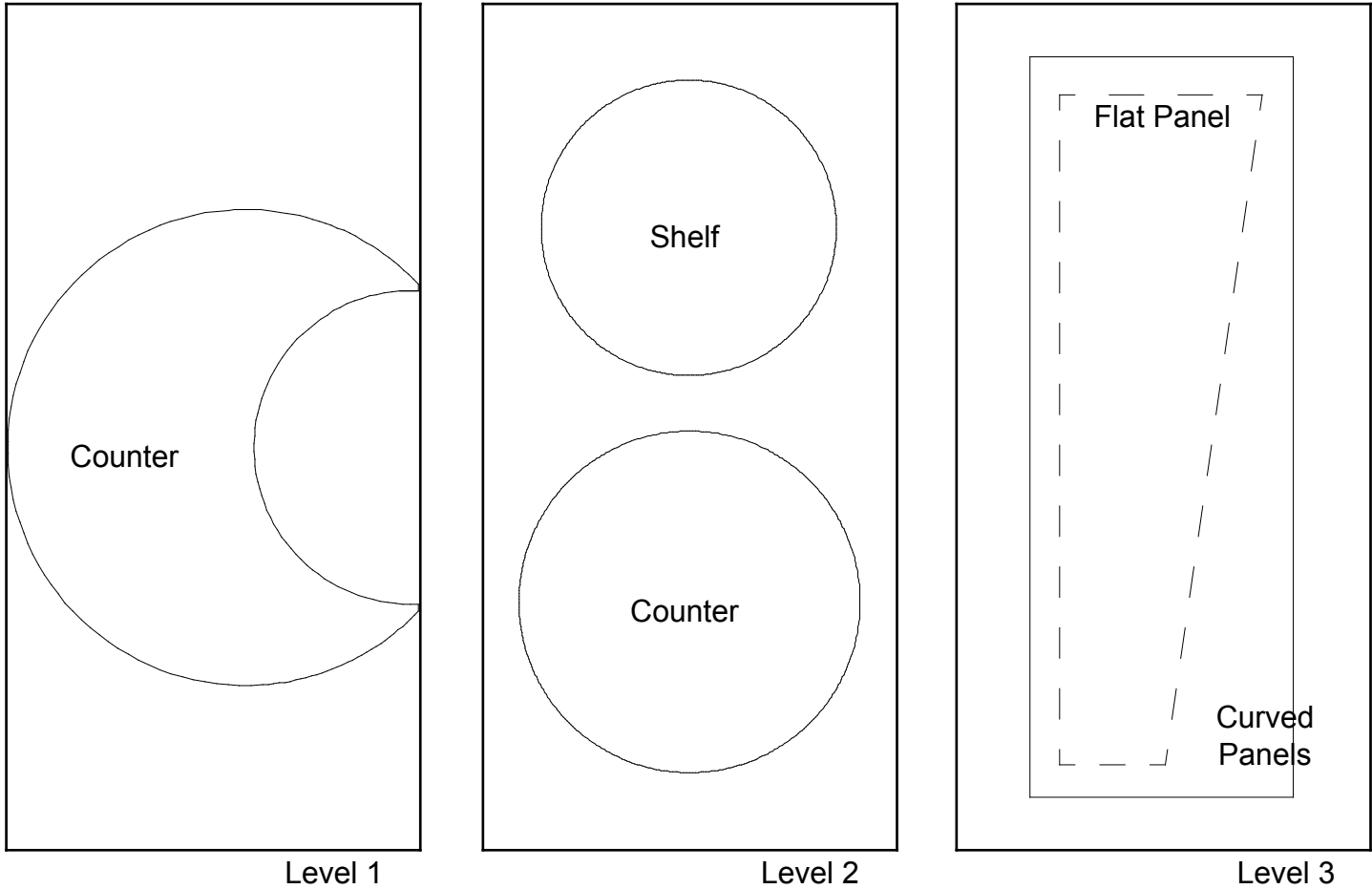

WHEN DISASSEMBLING ALUMINUM EXTRUSION, TIGHTEN ALL SETSCREWS AND LOCKS TO PREVENT LOSS DURING SHIPPING

View of Each Level

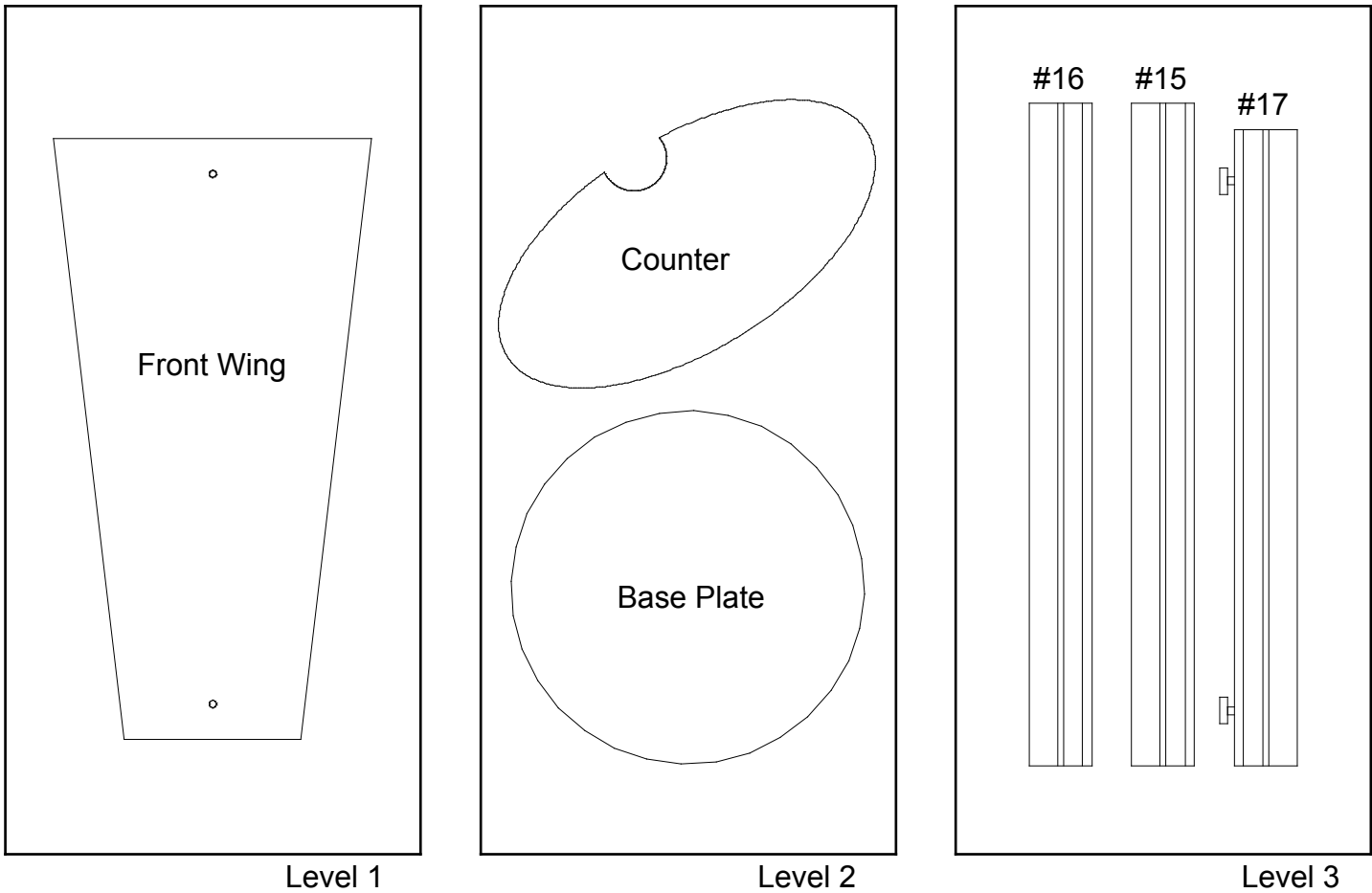

WHEN DISASSEMBLING ALUMINUM EXTRUSION, TIGHTEN ALL SETSCREWS AND LOCKS TO PREVENT LOSS DURING SHIPPING