

10'

10'

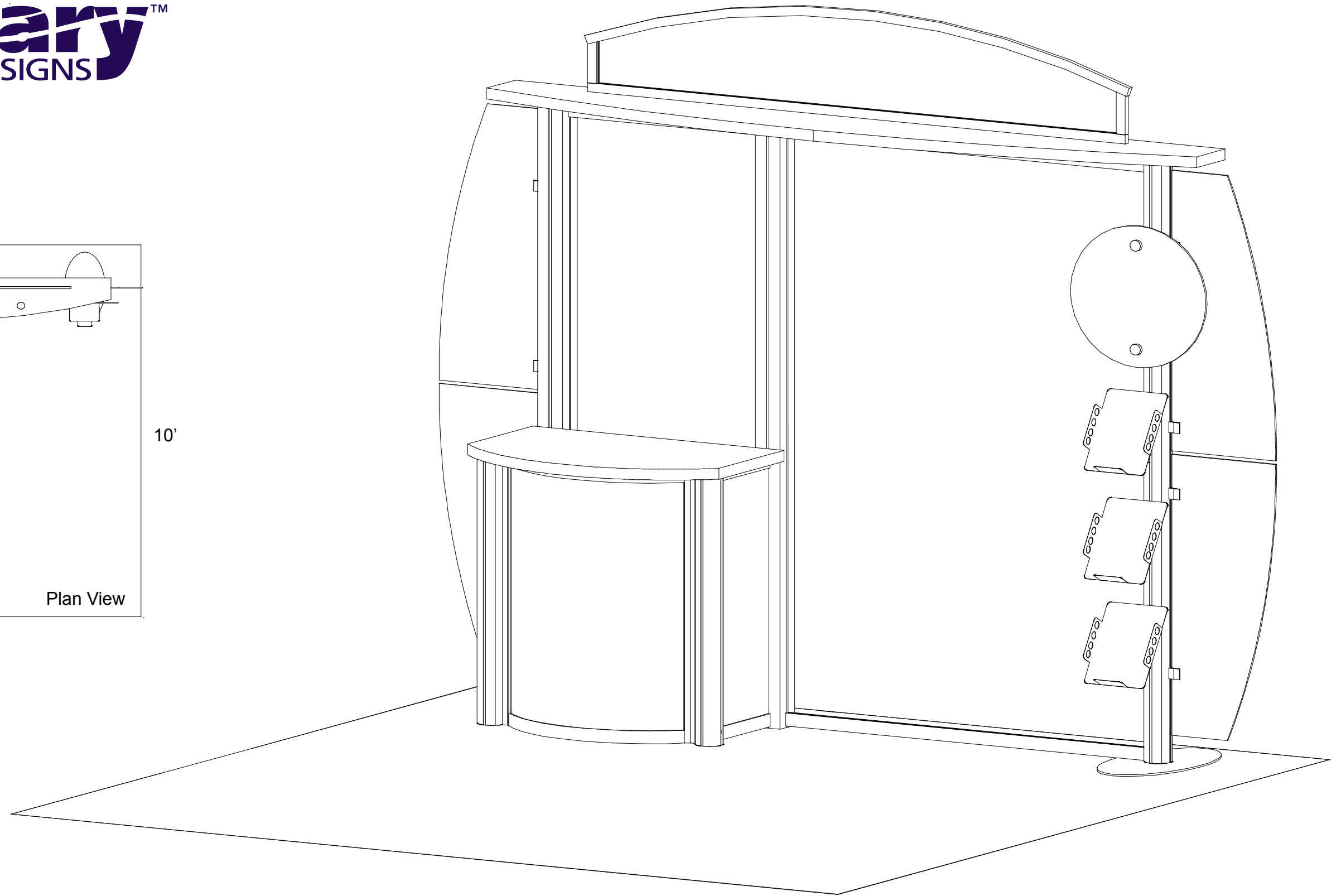

WHEN DISASSEMBLING ALUMINUM EXTRUSION, TIGHTEN ALL SETSCREWS AND LOCKS TO PREVENT LOSS DURING SHIPPING

# visionary™ IDESIGNS

## Using Your Setup Instructions

The Visionary Designs Setup Instructions are created specifically for your configuration. They are laid out sequentially, including an exploded view of the entire display, and then a logical series of detailed steps to assemble the main structure and components. We encourage you to study the instructions **before** attempting to assemble your exhibit.

Each page reminds you to tighten the setscrews after disassembling your exhibit to prevent loss of the locks and setscrews (see below in RED). This is **VERY IMPORTANT**.

## Cleaning and Packing Your Display

- 1) Use care when cleaning aluminum extrusion or acrylic inserts. Use only non-abrasive cleaners.
- 2) When cleaning laminate inserts or countertops, use mild cleansers and a soft material such as cotton.
- 3) Keep all display components away from extreme heat and long exposure to sunlight to avoid warping and fading.
- 4) Retain all packing material. It will make re-packing much easier and will reduce the likelihood of shipping damage.



**The Tool**

Most Visionary Designs exhibits can be assembled with the supplied Hex Key Tool. Occasionally, a flat head screwdriver may be required.



**Typical Connection**



**Typical Connection (cont'd)**

Most horizontal extrusion connections have a patented expandable lock. This lock inserts into the groove of an opposing extrusion. Tightening the lock with the Hex Key Tool expands the lock and creates a strong positive connection.

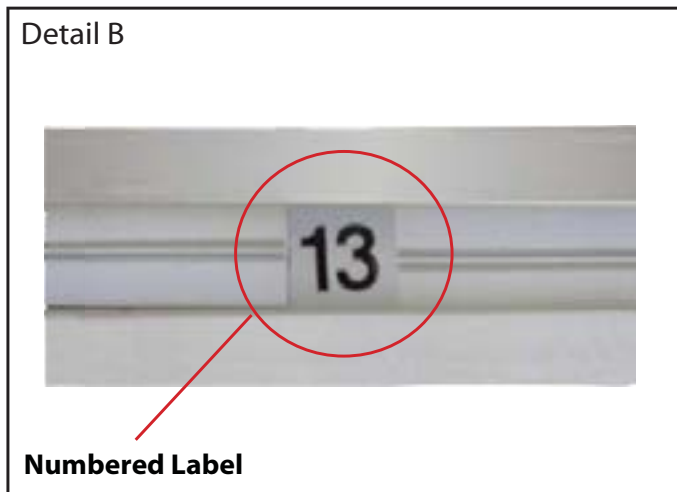

**Detail B**

**Numbered Label**

Each extrusion contains a numbered label which corresponds with setup instructions. The label is located within a groove of the extrusion (when possible). With Visionary Designs the labels contain Black numbers unless otherwise specified.



**Detail C**

**Horizontal Inline Connection** (remove only one setscrew)

Remove only (1) setscrew when disassembling. Replace setscrew in extrusion after assembling it. Before packing, replace setscrew in extrusion to avoid losing it.

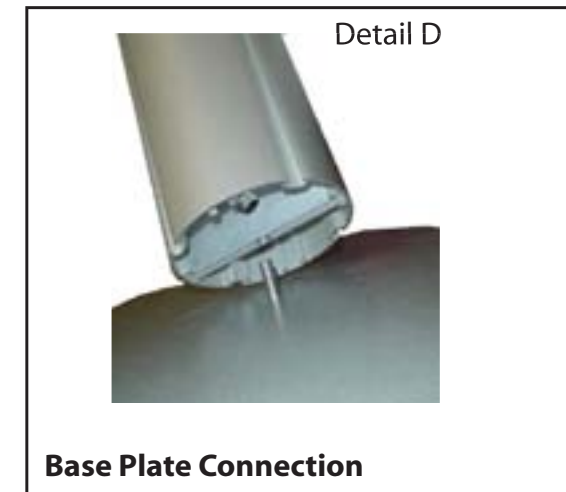

**Detail D**

**Base Plate Connection**

Attach base plate to round or square vertical extrusion using the bolt provided. Be careful not to strip the threads.

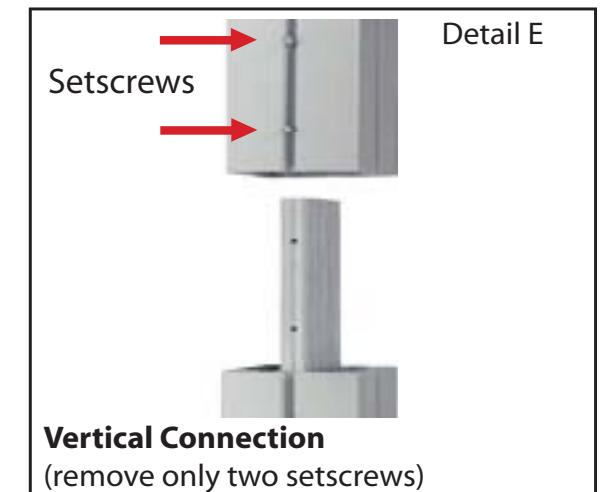

**Detail E**

**Vertical Connection**  
(remove only two setscrews)

When vertical extrusions are packed in portable cases rather than crates or tubs, they must be broken down into smaller sections which then require assembly.

Remove only (2) setscrews when disassembling. Replace setscrews in extrusion after assembling it. Before packing, replace setscrews in extrusion to avoid losing them.

**WHEN DISASSEMBLING ALUMINUM EXTRUSION, TIGHTEN ALL SETSCREWS AND LOCKS TO PREVENT LOSS DURING SHIPPING**

866.652.2100

Item	Qty.	Description
1	1	Oval Base Plates
2	1	84"h Vertical Extrusion w/ Canopy Attachment
3	1	84"h Vertical Extrusion
4	1	84"h Vertical Extrusion w/ Canopy Attachment
5A/5B	1/1	28" Horizontal Extrusion
6A/6B	1/1	52" Horizontal Extrusion

**Steps**

- 1) Attach vertical extrusion [4] to the oval base plate [1].
- 2) Attach horizontal extrusions [5A, 5B, 6A and 6B] between vertical extrusions [2, 3 and 4] as shown.
- 3) Apply graphics to assembled backwall.

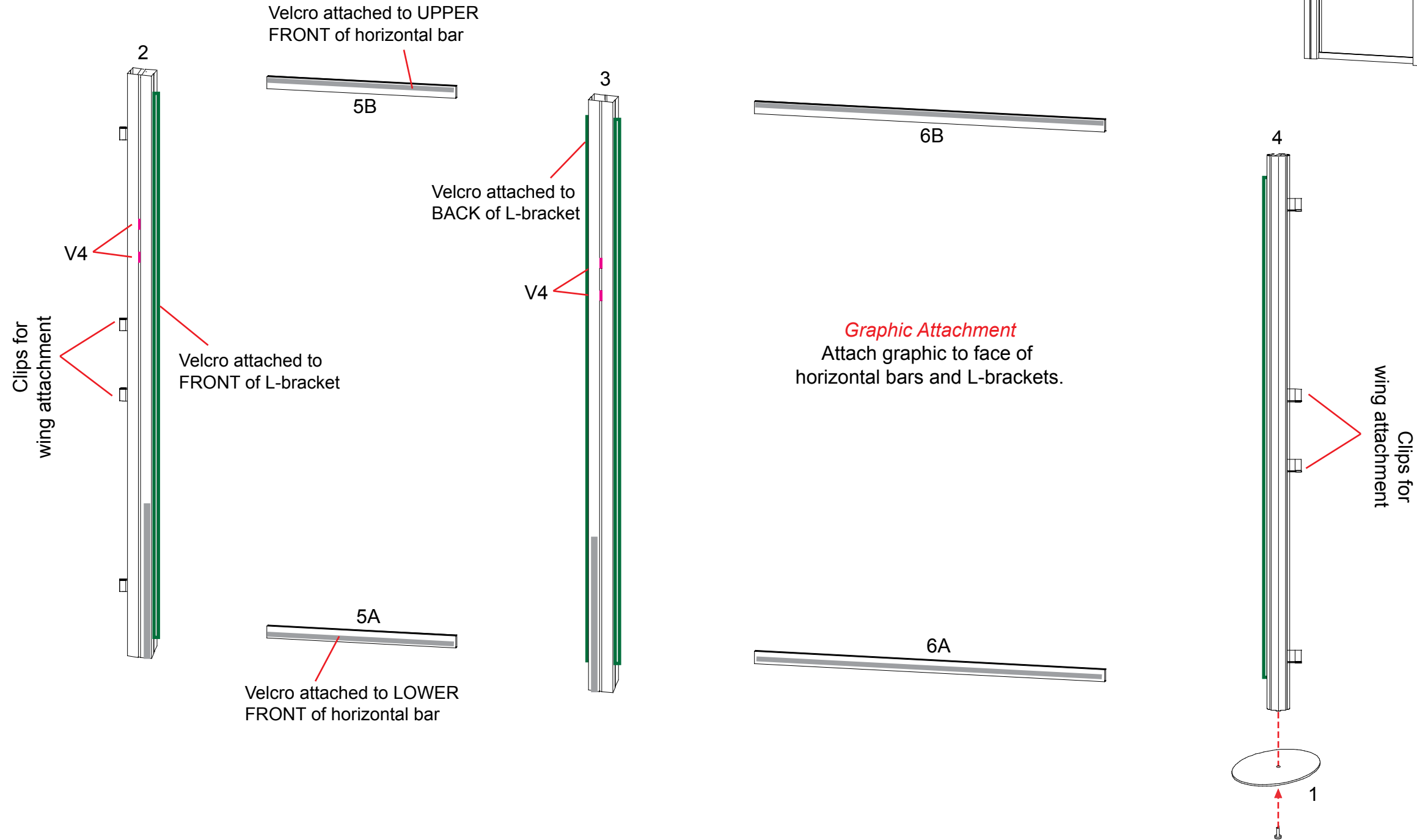
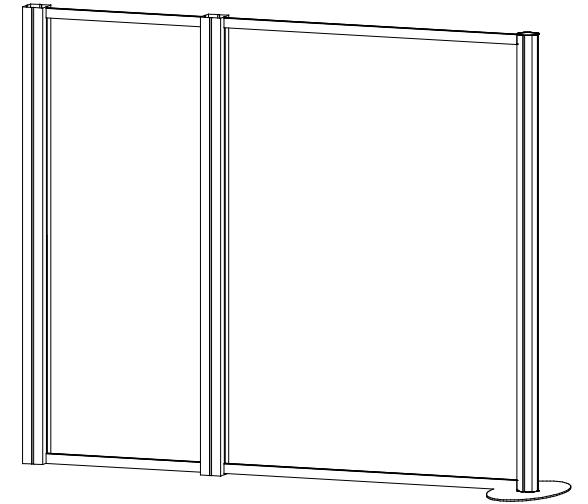

**WHEN DISASSEMBLING ALUMINUM EXTRUSION, TIGHTEN ALL SETSCREWS AND LOCKS TO PREVENT LOSS DURING SHIPPING**

866.652.2100

Item	Qty	Description
7	1	38" Vertical Extrusion w/ Door Stop
8	1	38" Vertical Extrusion w/ Door Hinge
9	4	12.5" Horizontal Extrusion
10	2	Curved Horizontal Extrusion
4		Internal Shelf Support

Steps

- 1) Attach lower horizontal extrusions [9,10] between vertical extrusions [2,3,7,8].
- 2) Insert infill panels and attach door.
- 3) Attach the upper horizontal extrusions [9,10] between verticals.
- 4) Velcro shelf supports to inside of assembled base.
- 5) Set internal shelf atop shelf supports.
- 6) Place counter top on assembled base.

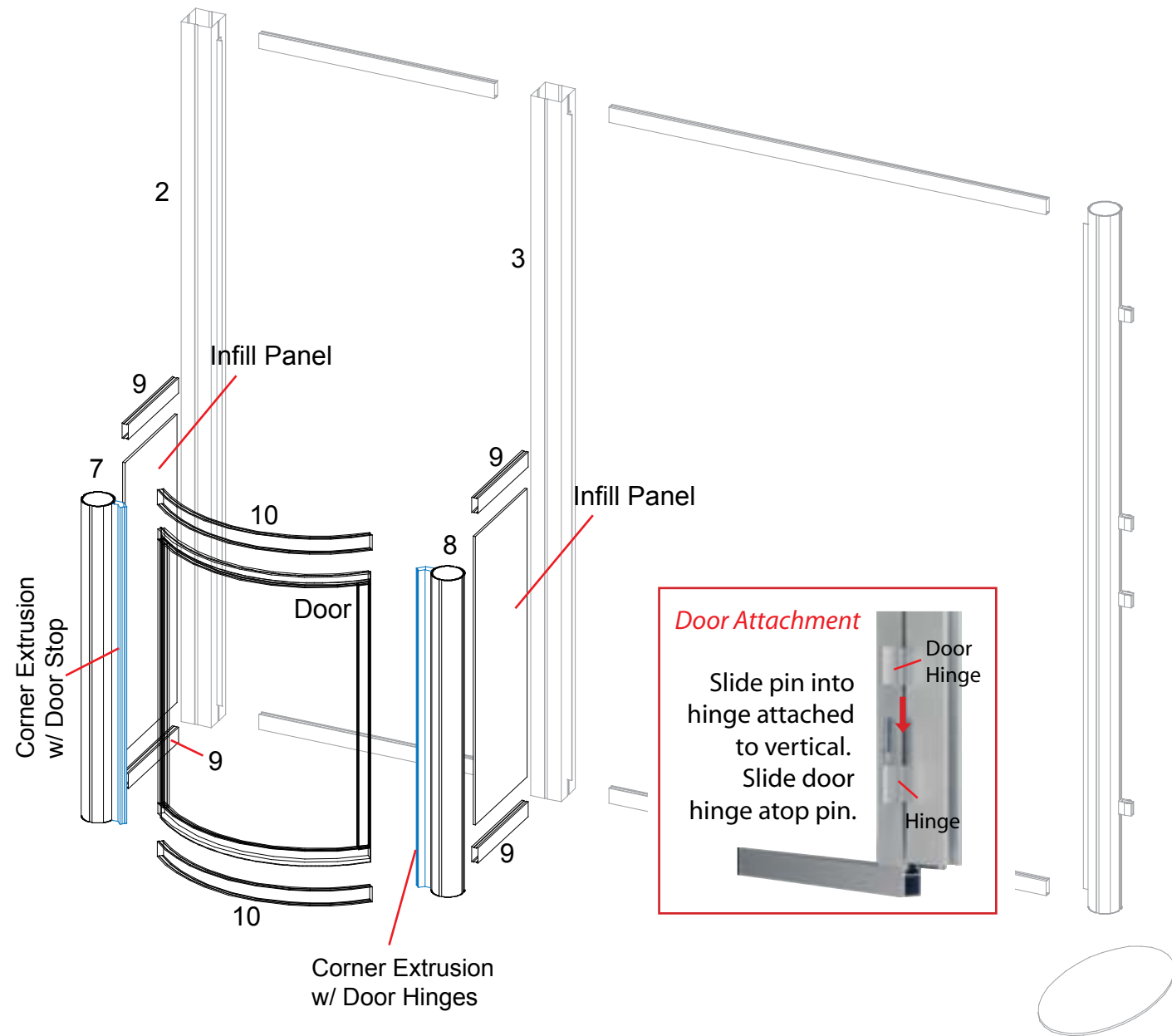

**Note:** Front section [7, 8, 10 and door] must stay assembled when shipping in crate.

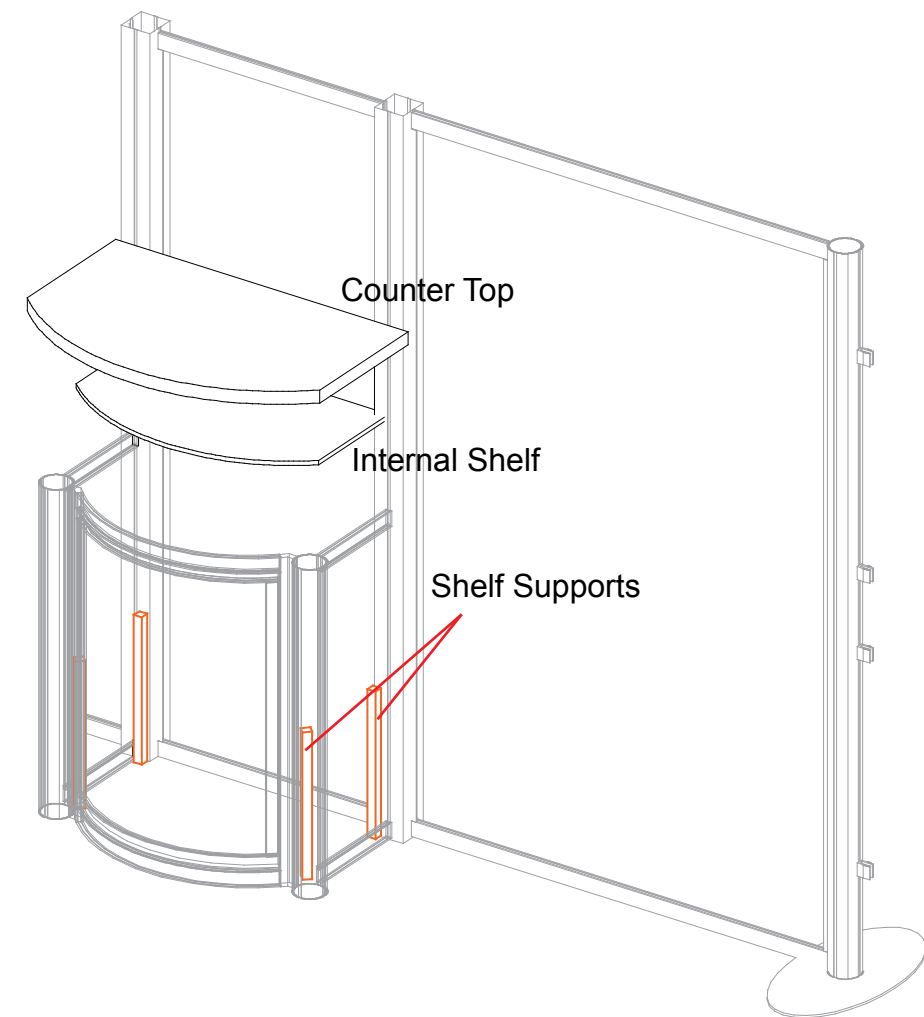
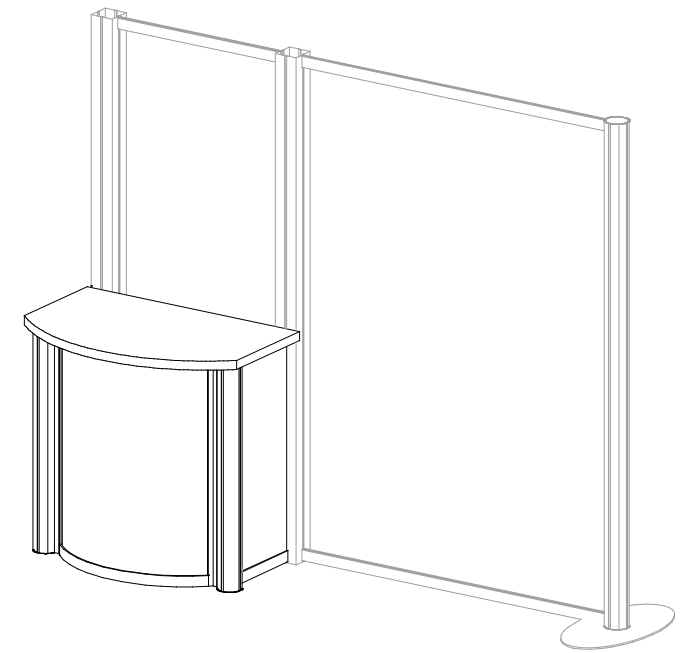

**WHEN DISASSEMBLING ALUMINUM EXTRUSION, TIGHTEN ALL SETSCREWS AND LOCKS TO PREVENT LOSS DURING SHIPPING**

866.652.2100

Item	Qty.	Description
11	1	5.862"w Vertical Extrusion
12	1	5.862"w Vertical Extrusion
13	1	80"w Horizontal Extrusion
14	1	80"w Curved Horizontal Extrusion

**Steps**

- 1) Connect vertical extrusions [11,12] to left and right side of horizontal extrusion [13].
- 2) Attach curved horizontal extrusion [14] to vertical extrusions [11,12].
- 3) Attach header to assembled backwall as shown.
- 4) Attach Sign using standoff barrels and caps.
- 5) Attach wings using A10 clamps as shown.
- 6) Attach literature racks and monitor mount as shown.

**Note:**  
 Attach header graphic to velcro at back of assembled header frame.  
 Header ships assembled. Do not take apart for packing.

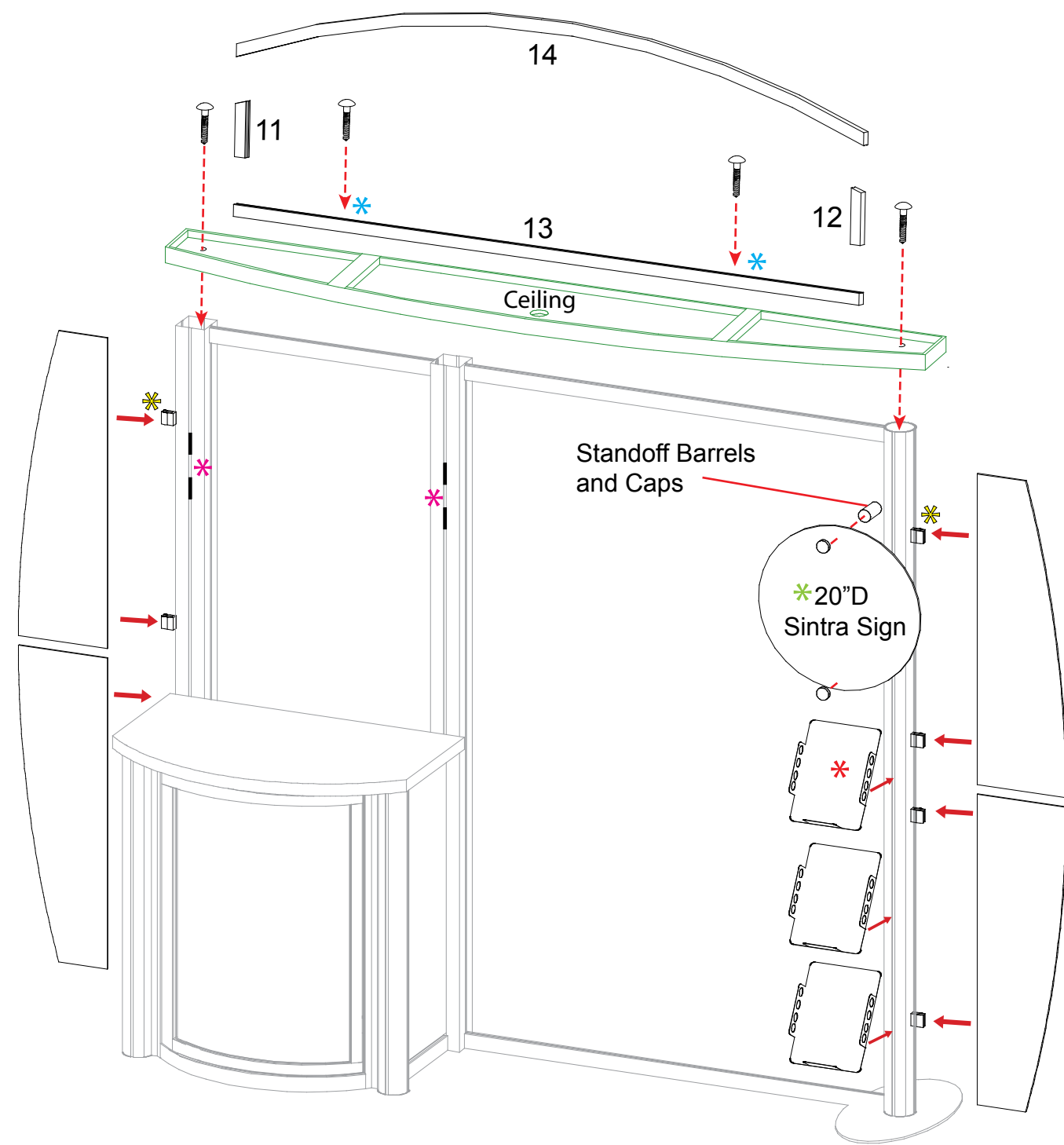
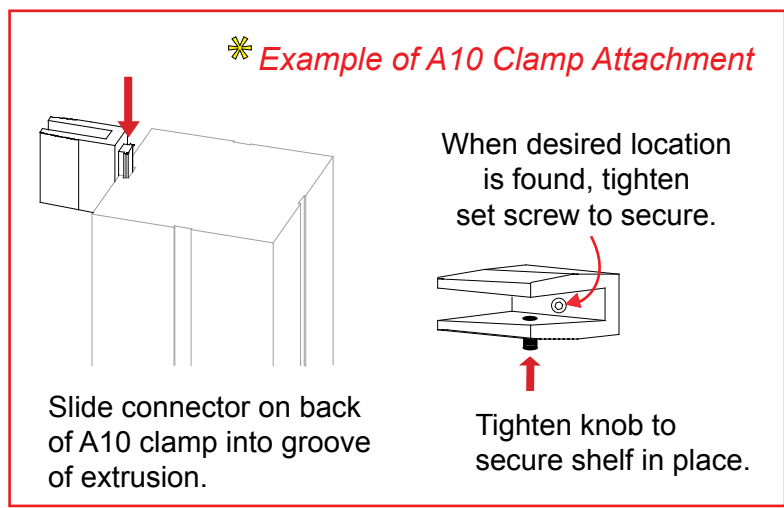
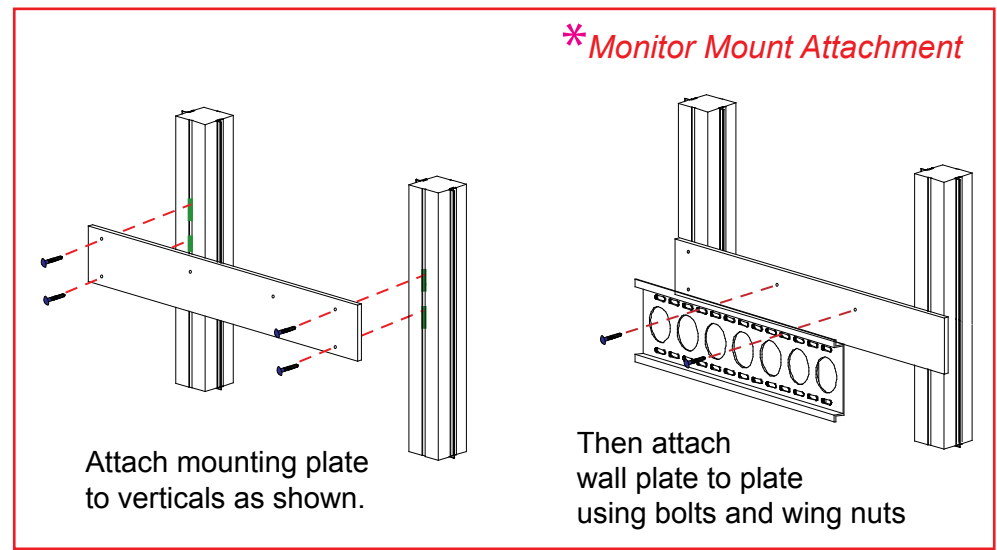
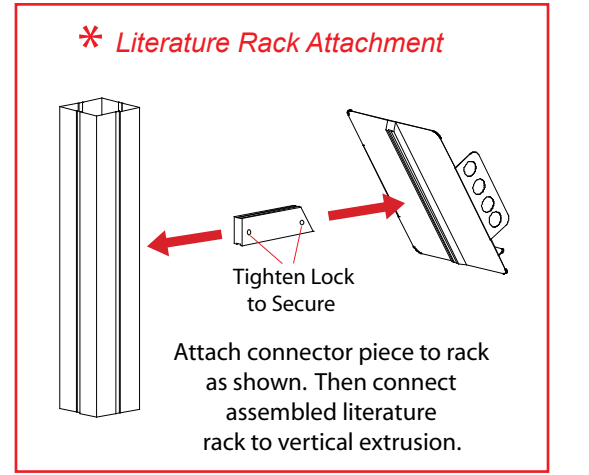
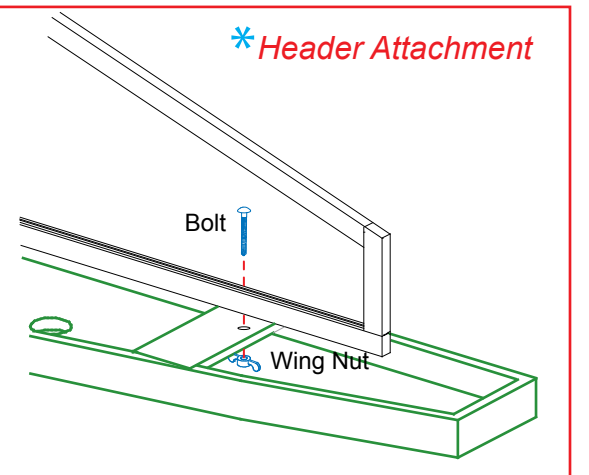
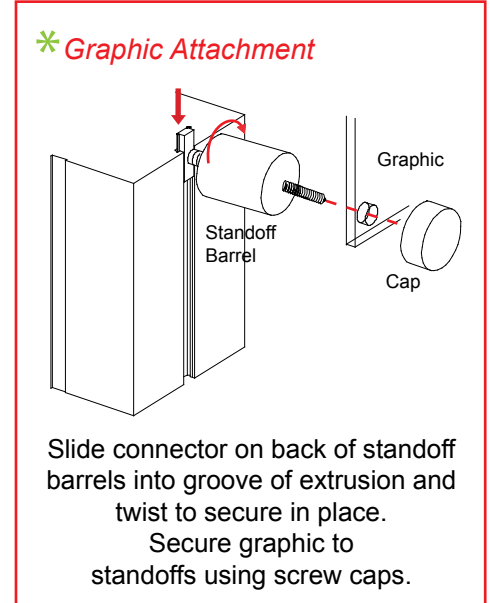

**WHEN DISASSEMBLING ALUMINUM EXTRUSION, TIGHTEN ALL SETSCREWS AND LOCKS TO PREVENT LOSS DURING SHIPPING**

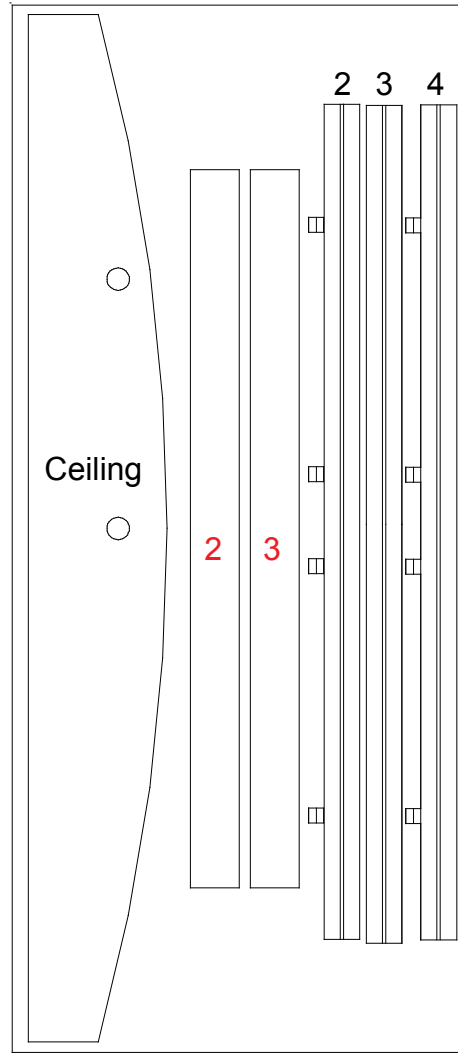

Level 1

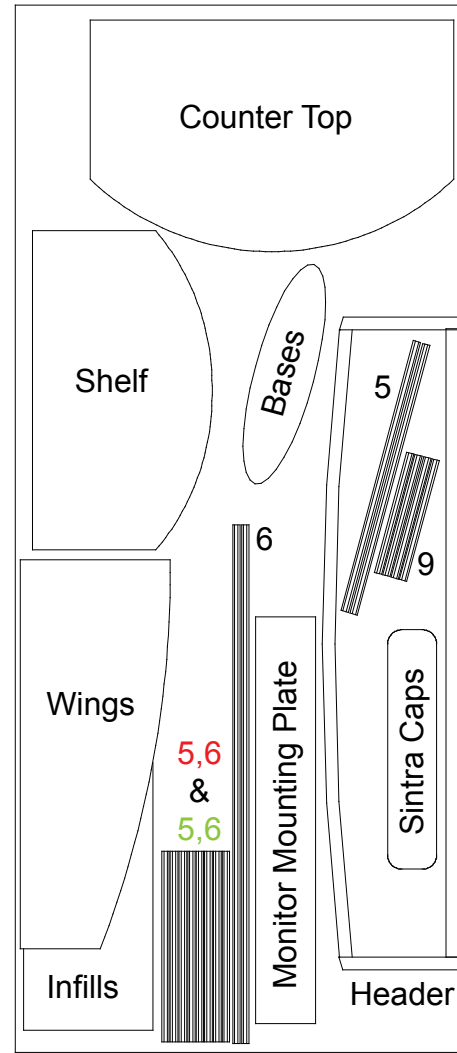

Level 2

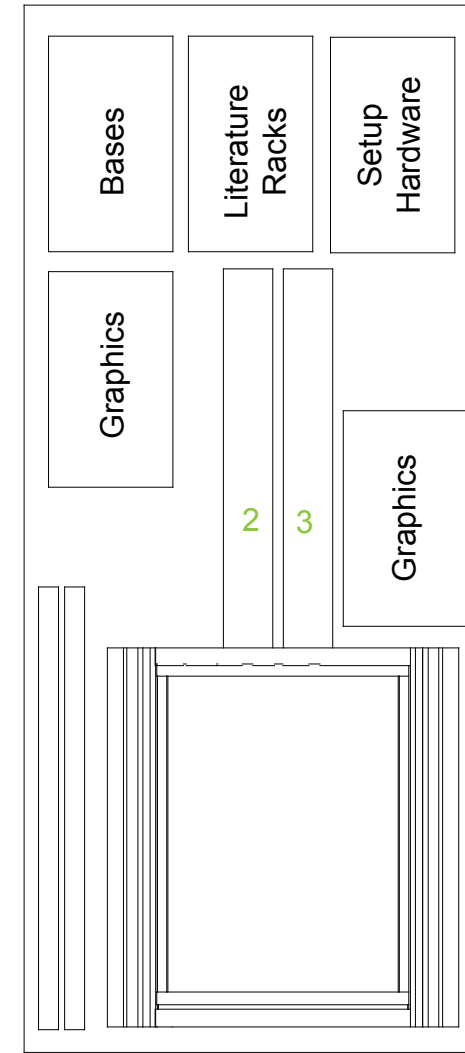

Level 3



WHEN DISASSEMBLING ALUMINUM EXTRUSION, TIGHTEN ALL SETSCREWS AND LOCKS TO PREVENT LOSS DURING SHIPPING