

WHEN DISASSEMBLING ALUMINUM EXTRUSION, TIGHTEN ALL SETSCREWS AND LOCKS TO PREVENT LOSS DURING SHIPPING

visionary™ IDESIGNS

Using Your Setup Instructions

The Visionary Designs Setup Instructions are created specifically for your configuration. They are laid out sequentially, including an exploded view of the entire display, and then a logical series of detailed steps to assemble the main structure and components. We encourage you to study the instructions **before** attempting to assemble your exhibit.

Each page reminds you to tighten the setscrews after disassembling your exhibit to prevent loss of the locks and setscrews (see below in RED). This is **VERY IMPORTANT**.

Cleaning and Packing Your Display

- 1) Use care when cleaning aluminum extrusion or acrylic inserts. Use only non-abrasive cleaners.
- 2) When cleaning laminate inserts or countertops, use mild cleansers and a soft material such as cotton.
- 3) Keep all display components away from extreme heat and long exposure to sunlight to avoid warping and fading.
- 4) Retain all packing material. It will make re-packing much easier and will reduce the likelihood of shipping damage.



The Tool

Most Visionary Designs exhibits can be assembled with the supplied Hex Key Tool. Occasionally, a flat head screwdriver may be required.



Detail A

Typical Connection



Typical Connection (cont'd)

Most horizontal extrusion connections have a patented expandable lock. This lock inserts into the groove of an opposing extrusion. Tightening the lock with the Hex Key Tool expands the lock and creates a strong positive connection.

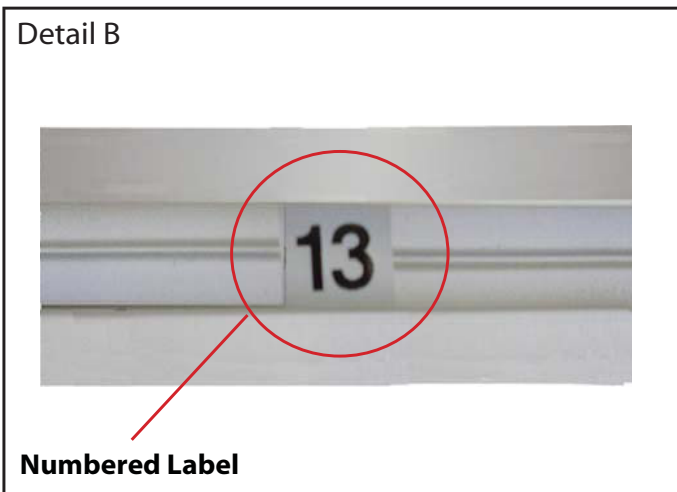

Detail B

Numbered Label

Each extrusion contains a numbered label which corresponds with setup instructions. The label is located within a groove of the extrusion (when possible). With Visionary Designs the labels contain Black numbers unless otherwise specified.



Detail C

Horizontal Inline Connection (remove only one setscrew)

Remove only (1) setscrew when disassembling. Replace setscrew in extrusion after assembling it. Before packing, replace setscrew in extrusion to avoid losing it.

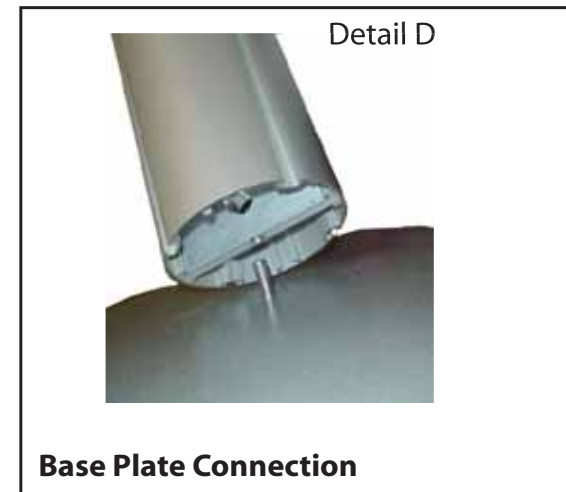

Detail D

Base Plate Connection

Attach base plate to round or square vertical extrusion using the bolt provided. Be careful not to strip the threads.

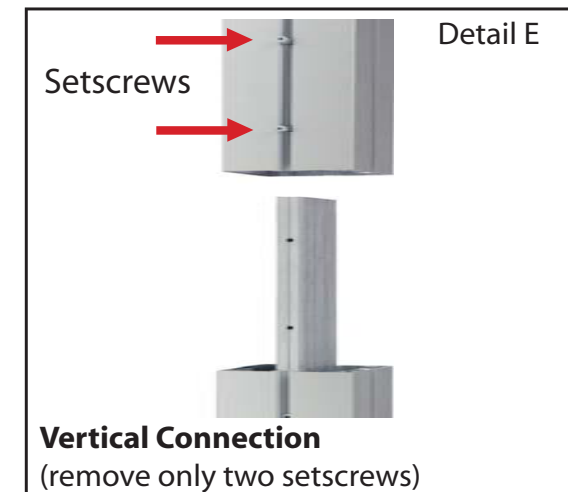

Detail E

Vertical Connection
(remove only two setscrews)

When vertical extrusions are packed in portable cases rather than crates or tubs, they must be broken down into smaller sections which then require assembly.

Remove only (2) setscrews when disassembling. Replace setscrews in extrusion after assembling it. Before packing, replace setscrews in extrusion to avoid losing them.



WHEN DISASSEMBLING ALUMINUM EXTRUSION, TIGHTEN ALL SETSCREWS AND LOCKS TO PREVENT LOSS DURING SHIPPING

Item	Qty.	Description
44a/44b	1/1	92" w Horizontal Extrusion
45	1	88.4180" h Vertical Extrusion
46	1	92" h Vertical Extrusion w/ Door Hinges
47	1	92" h Vertical Extrusion w/ Door Stopper
48	1	7.74" w Horizontal Extrusion
49	1	30" w Door Threshold
50	1	7.74" w Horizontal Extrusion
51	1	7.74" w Horizontal Extrusion
52	1	30" w Horizontal Extrusion
53	1	7.74" w Horizontal Extrusion
54	1	89.21" h Vertical Extrusion w/ Door Hinges
55	1	89.21" h Vertical Extrusion w/ Door Lock
56	1	25.52" w Horizontal Extrusion
57	1	25.52" w Horizontal Extrusion

Item	Qty.	Description
5	1	46" h Square Vertical Extrusion
6	1	46" h Square Vertical Extrusion
7	1	46" h Square Vertical Extrusion
8	1	46" h Square Vertical Extrusion
9	1	46" h Square Vertical Extrusion
10	1	46" h Square Vertical Extrusion
11	1	46" h Square Vertical Extrusion
12	1	46" h Square Vertical Extrusion
17	1	46" w Lower Horizontal Extrusion
18	1	46" w Lower Horizontal Extrusion

- Steps:
- 1) Attach upper square verticals [6, 8, 10, & 12] atop lower square verticals [5, 7, 9, & 11] as shown.
 - 2) Assemble door wall by attaching horizontals between verticals as shown. Note: Install door threshold first. Refer to detail.
 - 3) Attach door to vertical [46].
 - 4) Attach horizontal extrusions [17 & 18] together.
 - 5) Attach horizontal assembly and extrusions between vertical assemblies as shown.
 - 6) Attach monitor mount to vertical [45]. Refer to detail.

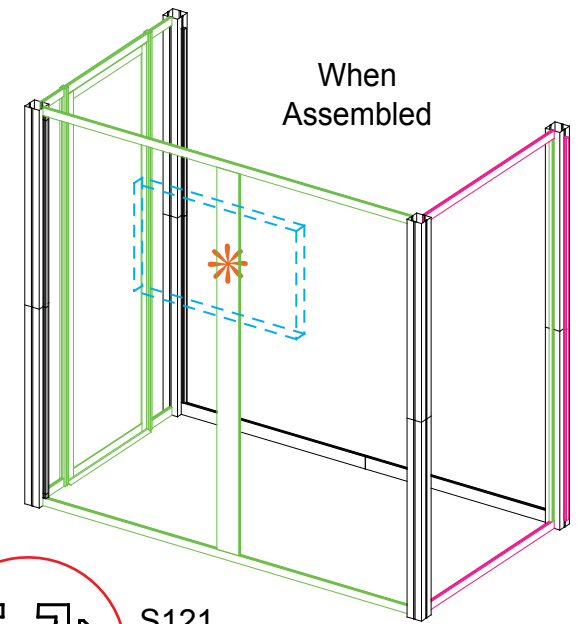

* Remove V4 connectors for monitor mount attachment before installing S121

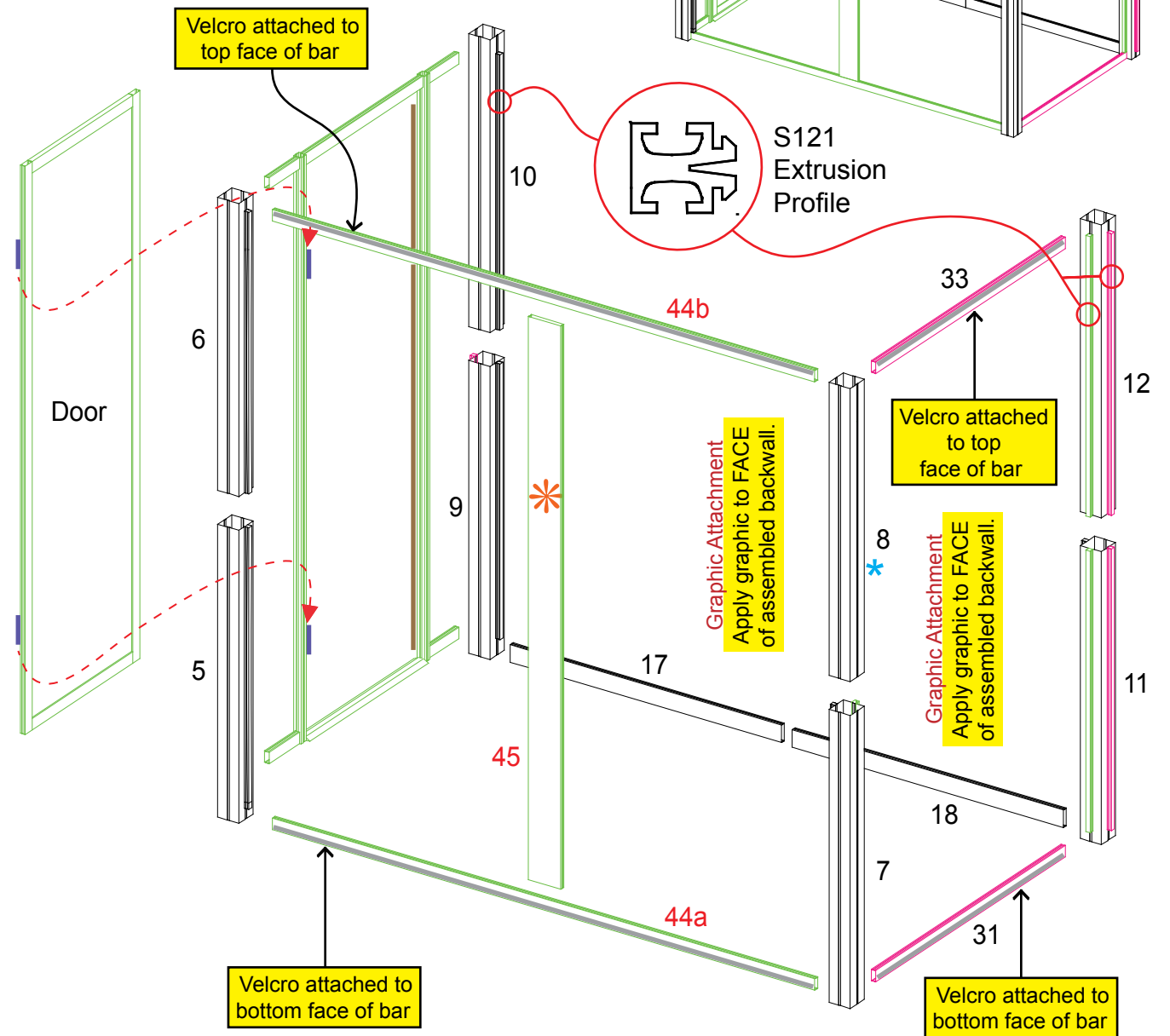
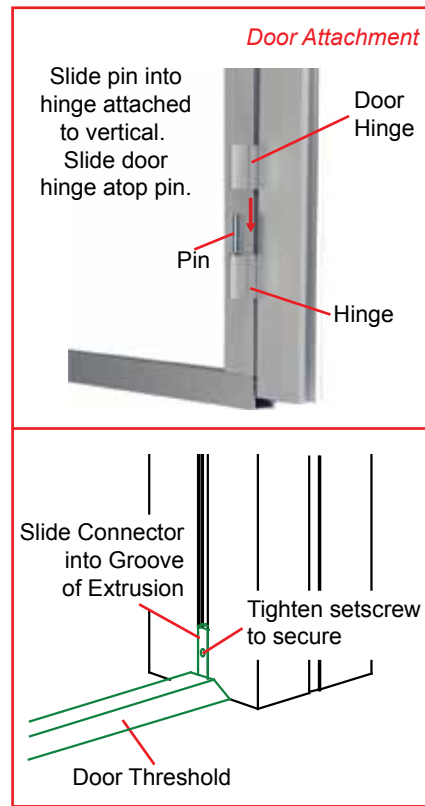
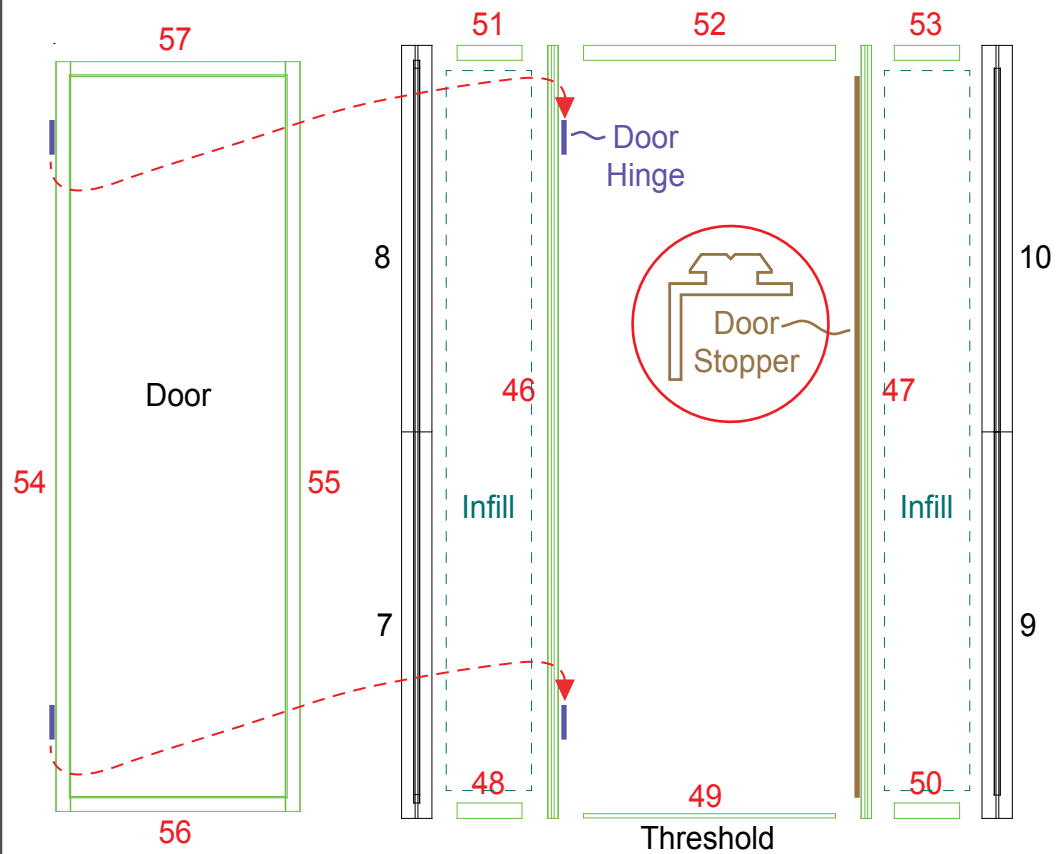

Pieces in BLACK are from 10x10
 Pieces in PINK are new pieces from 10x20
 Pieces in GREEN are new pieces for 20x20



WHEN DISASSEMBLING ALUMINUM EXTRUSION, TIGHTEN ALL SETSCREWS AND LOCKS TO PREVENT LOSS DURING SHIPPING

Item	Qty.	Description
39	1	Lighted Base
40	1	Lighted Base
43	1	Lighted Base
60	1	48" w Horizontal Extrusion
69	1	92" h Square Vertical Extrusion

Item	Qty.	Description
26	1	46" h Square Vertical Extrusion
27	1	46" h Square Vertical Extrusion
28	1	46" h Square Vertical Extrusion
29	1	46" h Square Vertical Extrusion
30	1	48" w Lower Horizontal Extrusion
32	1	48" w Lower Horizontal Extrusion

Steps:

- 1) Attach upper vertical extrusions [27 & 29] to lower vertical extrusions [26 & 28]. Refer to Extrusion Profile detail for correct positioning.
- 2) Attach horizontal extrusions [30 & 32] between vertical assemblies as shown.
- 3) Attach horizontal extrusion [60] between vertical assembly and vertical extrusion as shown.
- 4) Rest lighted bases against lower horizontal extrusions as shown.

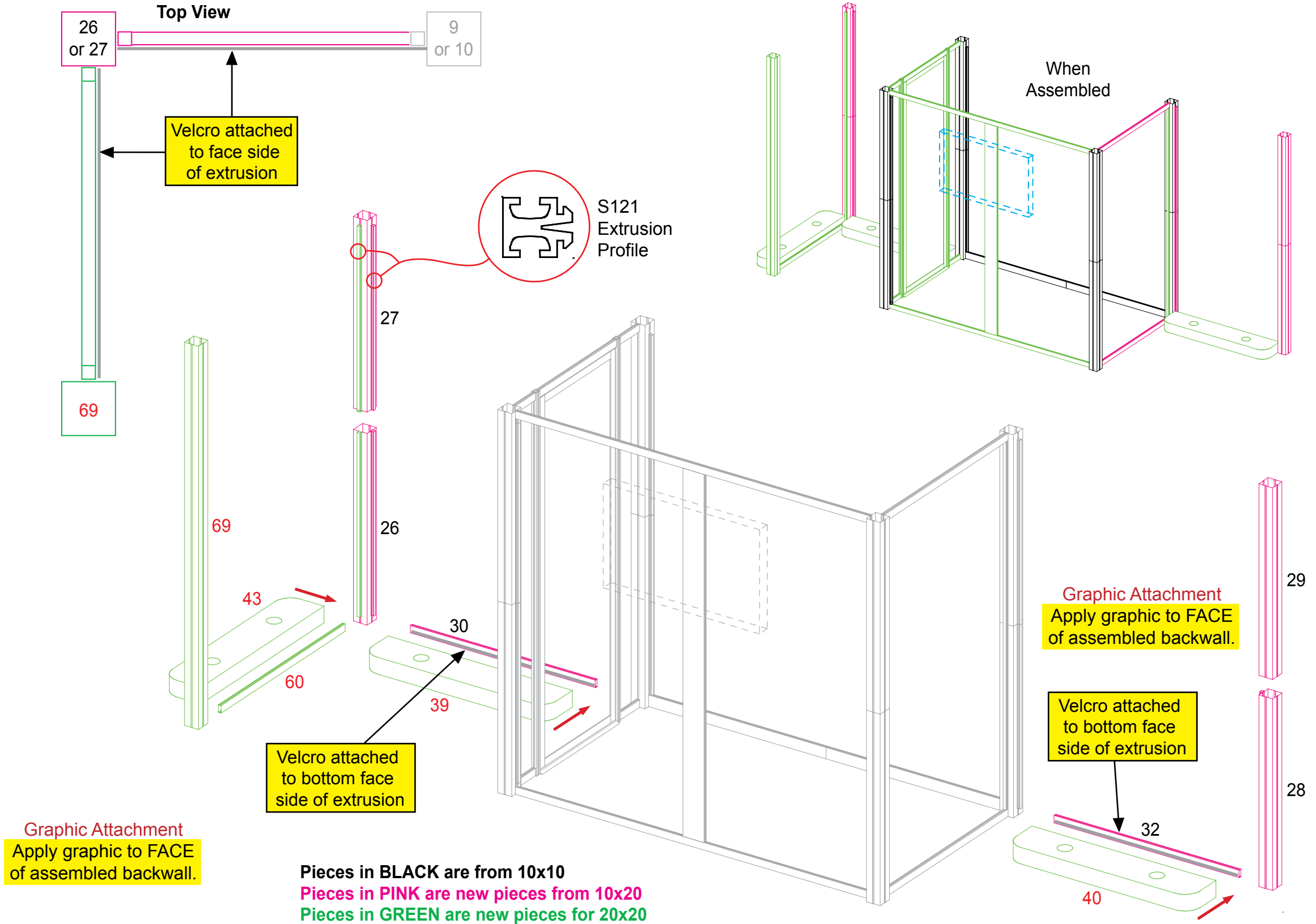

WHEN DISASSEMBLING ALUMINUM EXTRUSION, TIGHTEN ALL SETSCREWS AND LOCKS TO PREVENT LOSS DURING SHIPPING

Item	Qty.	Description
42	1	Lighted Base
59	1	48" w Horizontal Extrusion
65	1	92" h Square Vertical Extrusion
67	1	92" h Square Vertical Extrusion

Steps:

- 1) Attach horizontal extrusion [59] between vertical extrusions [67 & 65].
- 2) Attach lighted base [42] to vertical extrusions [67 & 65] using bolts as shown.
- 3) Attach literature pamphlet trays to vertical. Refer to *Adjustable Pamphlet Tray Attachment* detail.

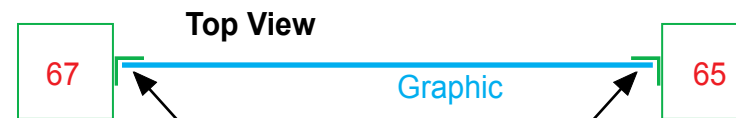

Graphic Attachment
Apply graphic to FACE of assembled sheer wall

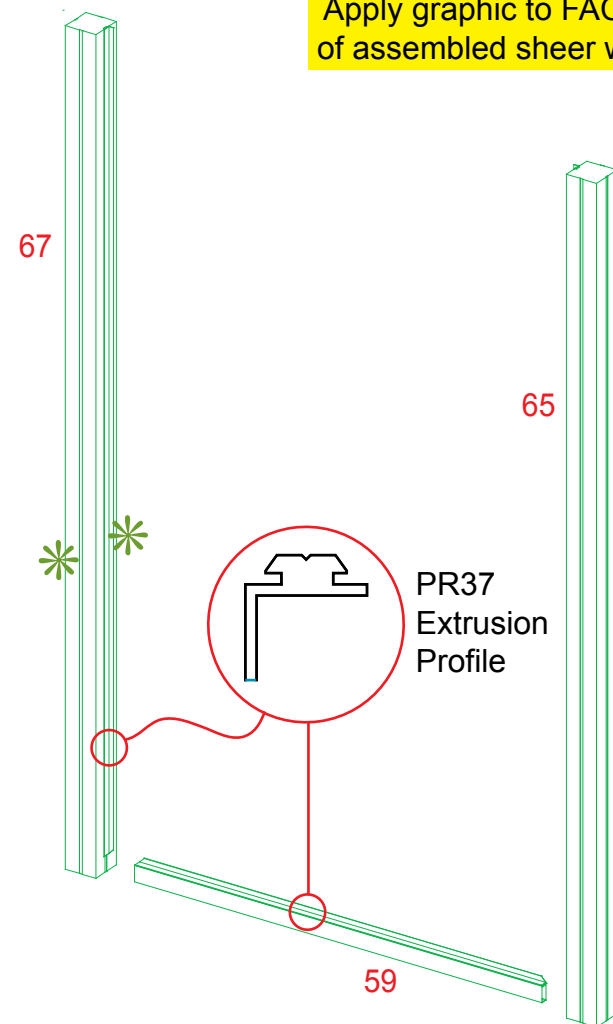
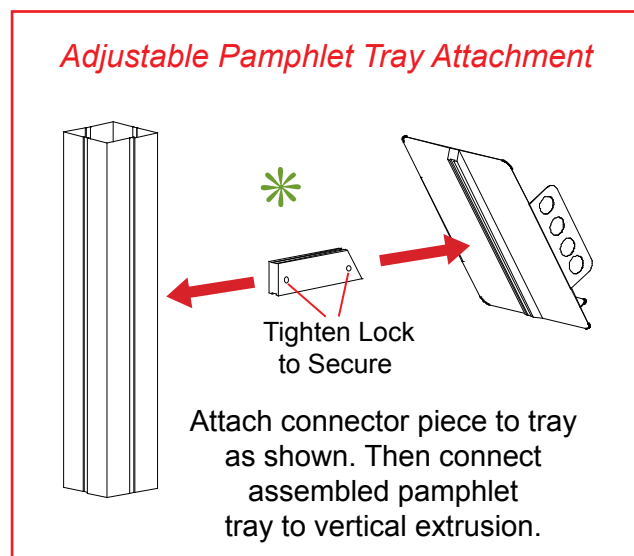
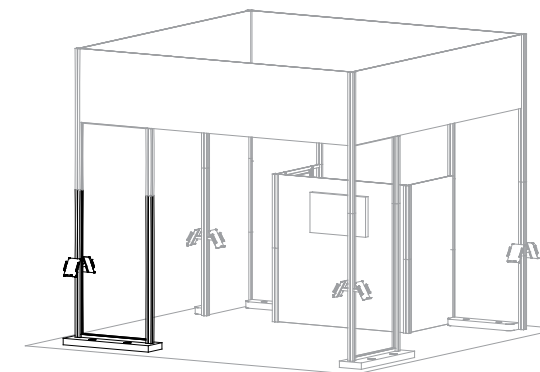

Pieces in GREEN are new pieces for 20x20

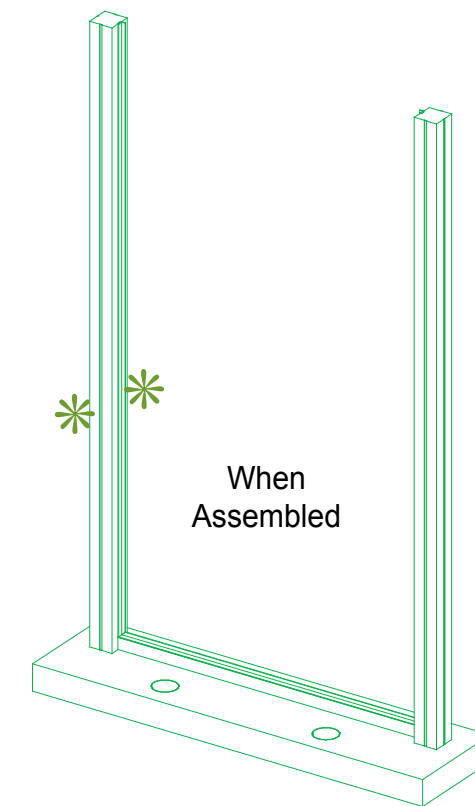
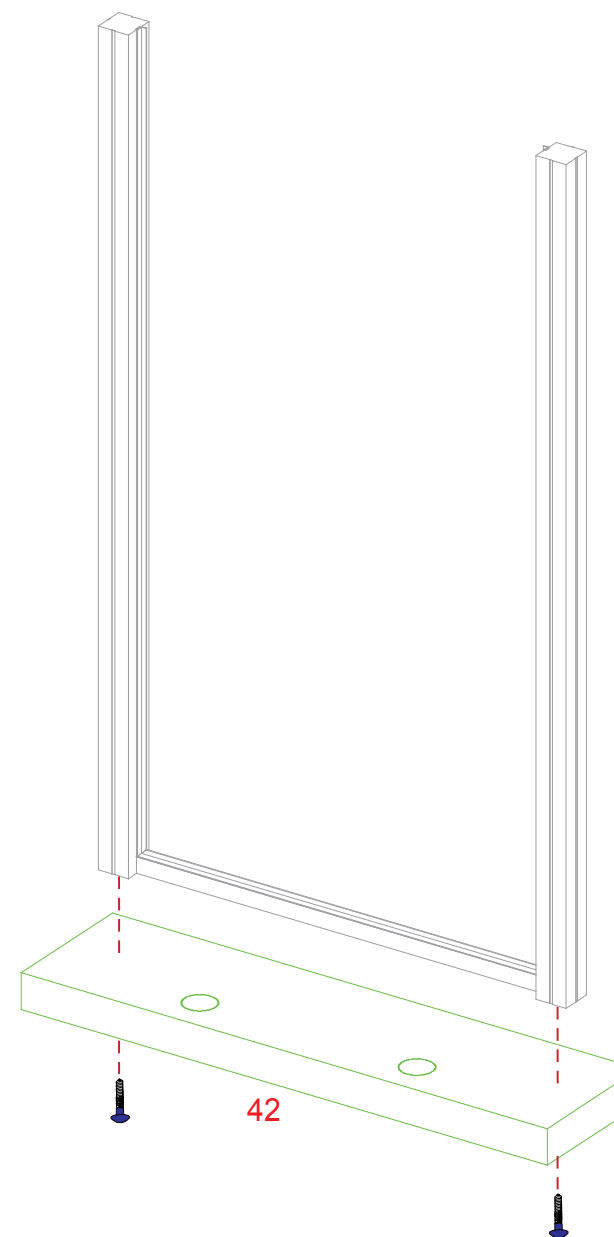

WHEN DISASSEMBLING ALUMINUM EXTRUSION, TIGHTEN ALL SETSCREWS AND LOCKS TO PREVENT LOSS DURING SHIPPING

Item	Qty.	Description
41	1	Lighted Base
58	1	48" w Horizontal Extrusion
61	1	92" h Square Vertical Extrusion
63	1	92" h Square Vertical Extrusion

- Steps:
- 1) Attach horizontal extrusion [58] between vertical extrusions [61 & 63].
 - 2) Attach lighted base [41] to vertical extrusions [61 & 63] using bolts as shown.
 - 3) Attach literature pamphlet trays to vertical. Refer to *Adjustable Pamphlet Tray Attachment* detail.

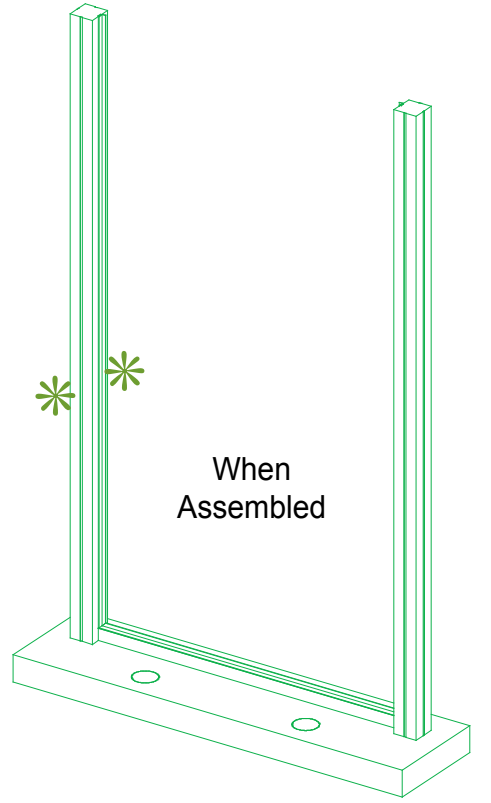
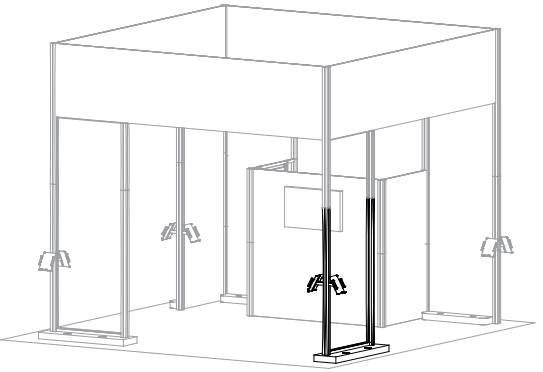
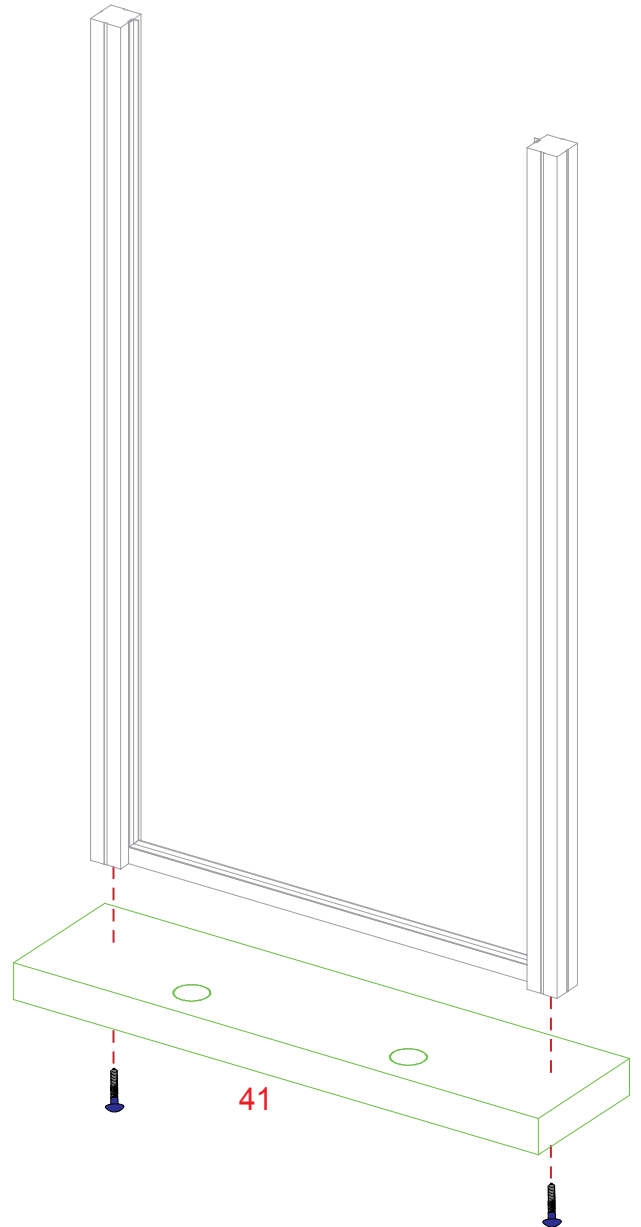
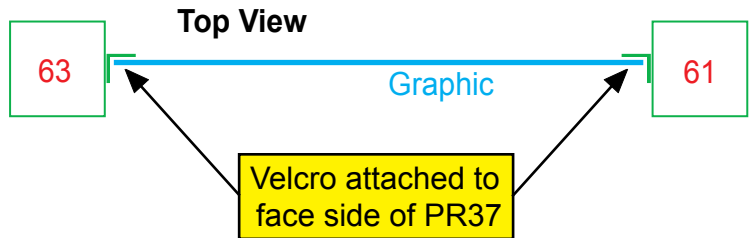
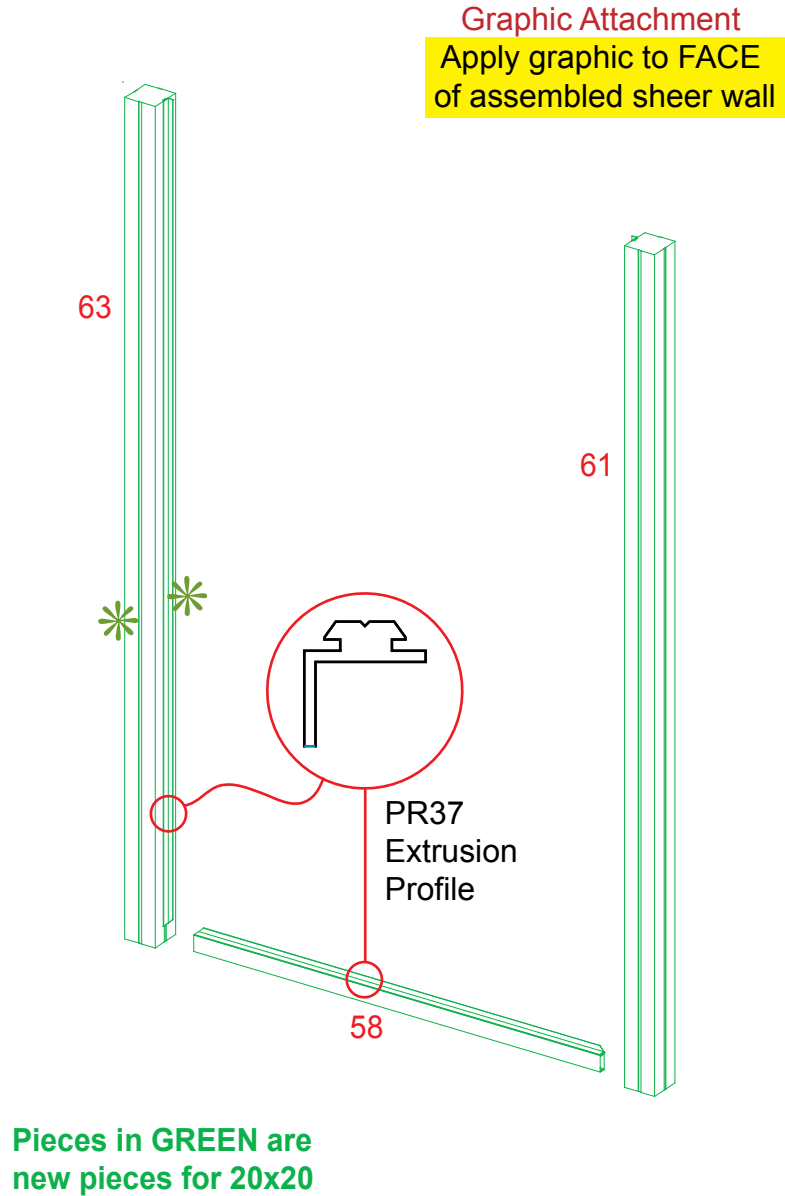
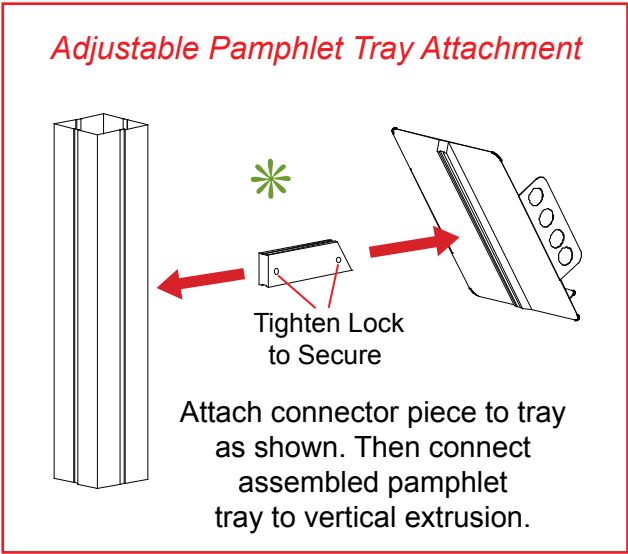

WHEN DISASSEMBLING ALUMINUM EXTRUSION, TIGHTEN ALL SETSCREWS AND LOCKS TO PREVENT LOSS DURING SHIPPING

Item	Qty.	Description
61	1	92"h Square Vertical Extrusion
62	1	42"h Square Vertical Extrusion
63	1	92"h Square Vertical Extrusion
64	1	88"h Square Vertical Extrusion
65	1	92"h Square Vertical Extrusion
66	1	42"h Square Vertical Extrusion
67	1	92"h Square Vertical Extrusion
68	1	88"h Square Vertical Extrusion
69	1	92"h Square Vertical Extrusion
70	1	46"h Square Vertical Extrusion
71	1	92"h Square Vertical Extrusion
72	1	46"h Square Vertical Extrusion
73	1	46"h Square Vertical Extrusion
74	1	92"h Square Vertical Extrusion
75-98	1 ea.	65.0550"w Horizontal Extrusion
99	8	42.4180"h Vertical Extrusion

Item	Qty.	Description
10	1	46"h Square Vertical Extrusion
12	1	46"h Square Vertical Extrusion
27	1	46"h Square Vertical Extrusion
29	1	46"h Square Vertical Extrusion

- Steps:
- 1) Attach upper square vertical extrusions atop lower square vertical extrusions as shown.
 - 2) Attach verticals and horizontals together as shown.
- Note: Attach vertical extrusions [99] between horizontal assemblies [75 thru 98]. Refer to Extrusion Profile details.

Blue measurements (48") indicate lengths of S121 extrusions to attach.
S121 extrusions must remain attached to main extrusions

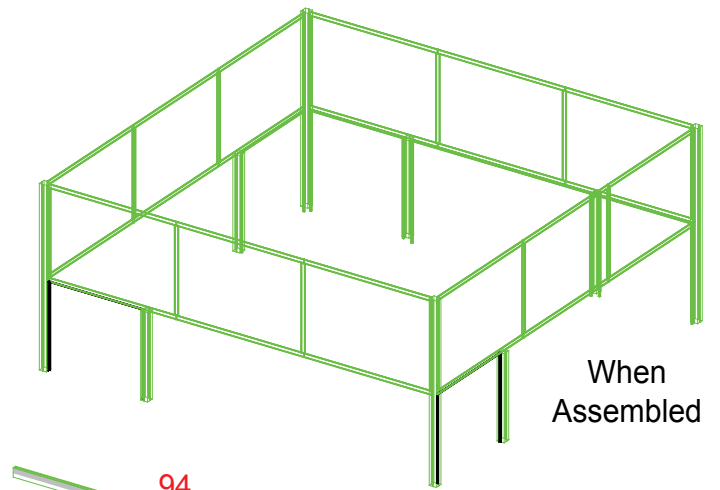

When Assembled

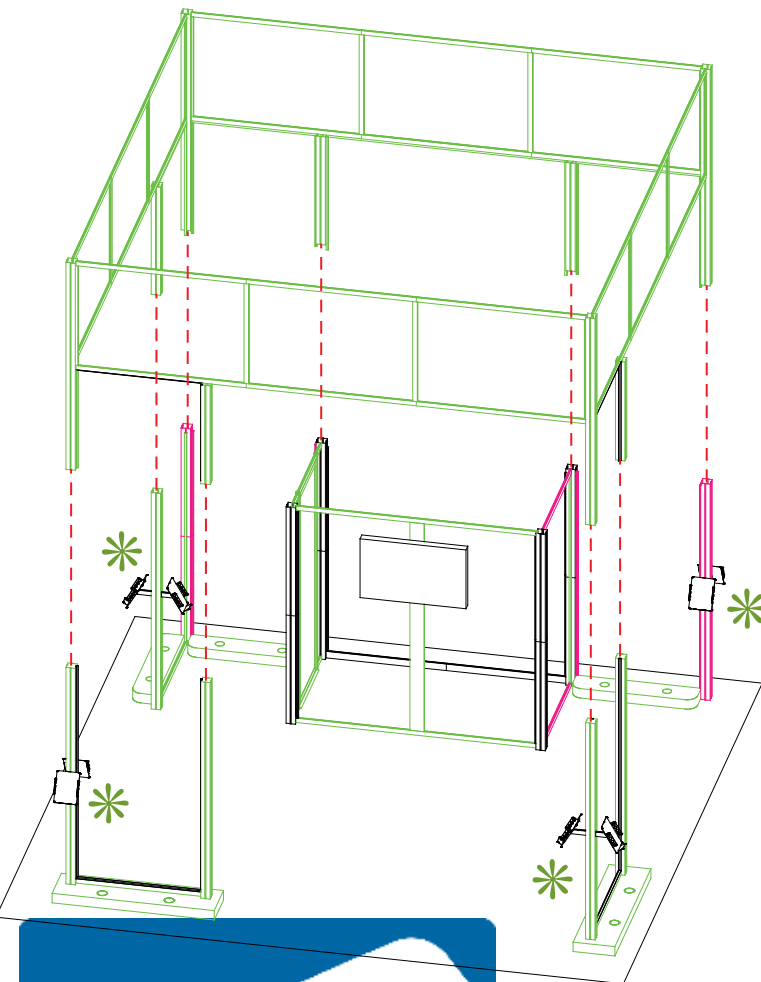

Graphic Attachment
 Apply graphic to **FACE** and **BACK** side of assembled structure

* literature pamphlet tray location

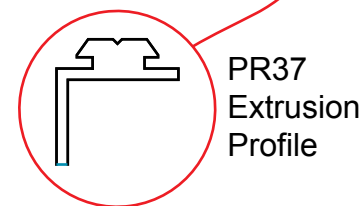

PR37 Extrusion Profile

Velcro attached around perimeter

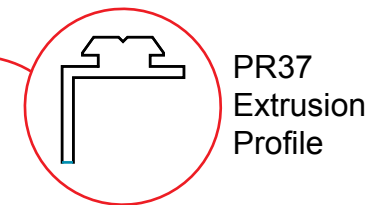

PR37 Extrusion Profile

Pieces in GREEN are new pieces for 20x20

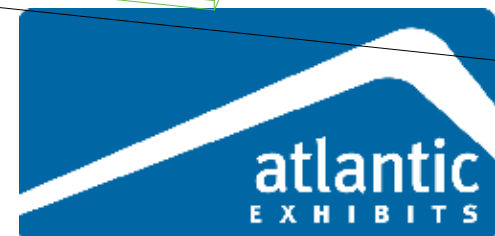

WHEN DISASSEMBLING ALUMINUM EXTRUSION, TIGHTEN ALL SETSCREWS AND LOCKS TO PREVENT LOSS DURING SHIPPING

Item	Qty.	Description
23	4	42”h Vertical Extrusion
24	2	25”w Horizontal Extrusion
25	2	17”w Horizontal Extrusion

- Steps:
- 1) Attach horizontal extrusions [24 & 25] between vertical extrusions [23].
 - 2) Place counter top on assembled pedestal and secure in place.

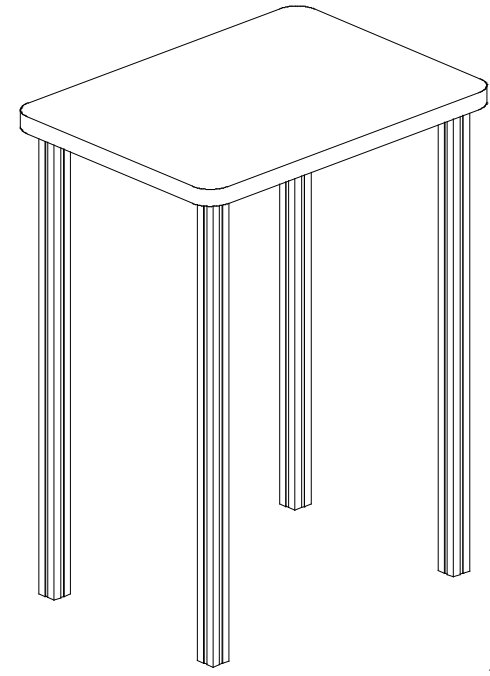
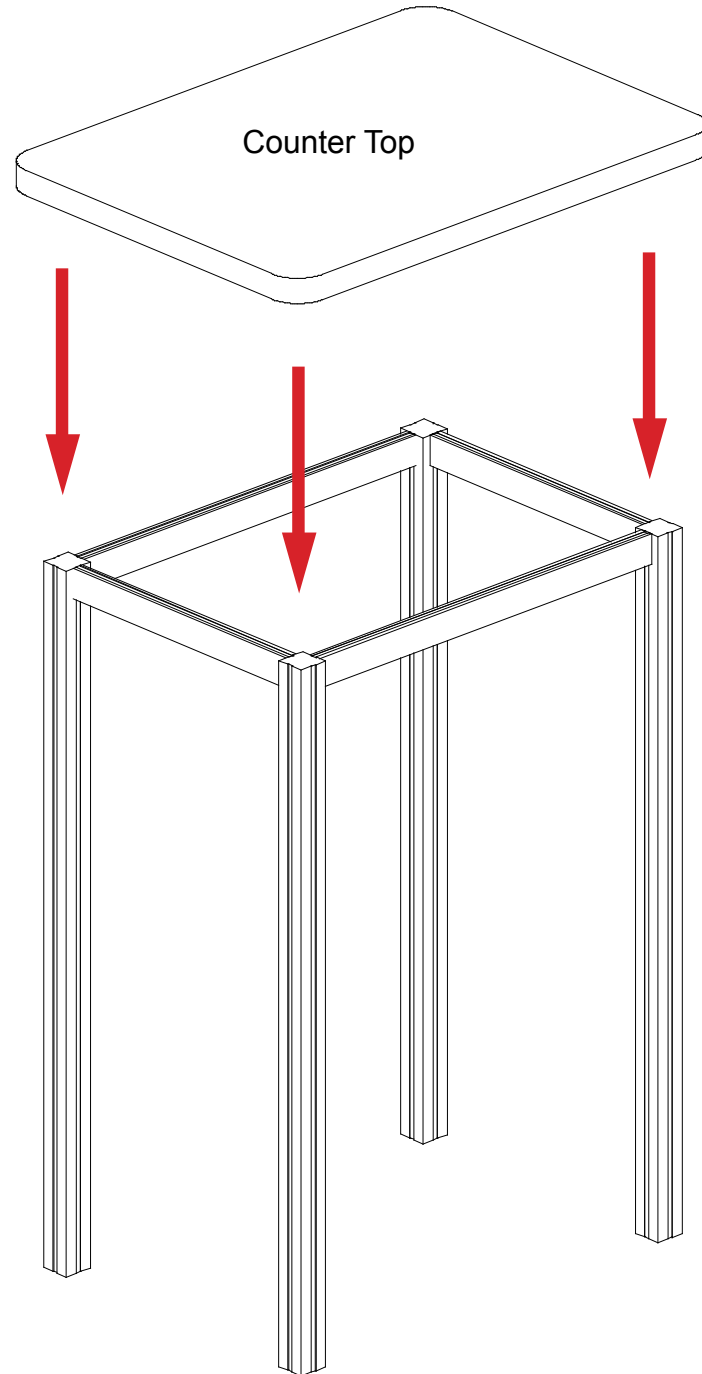
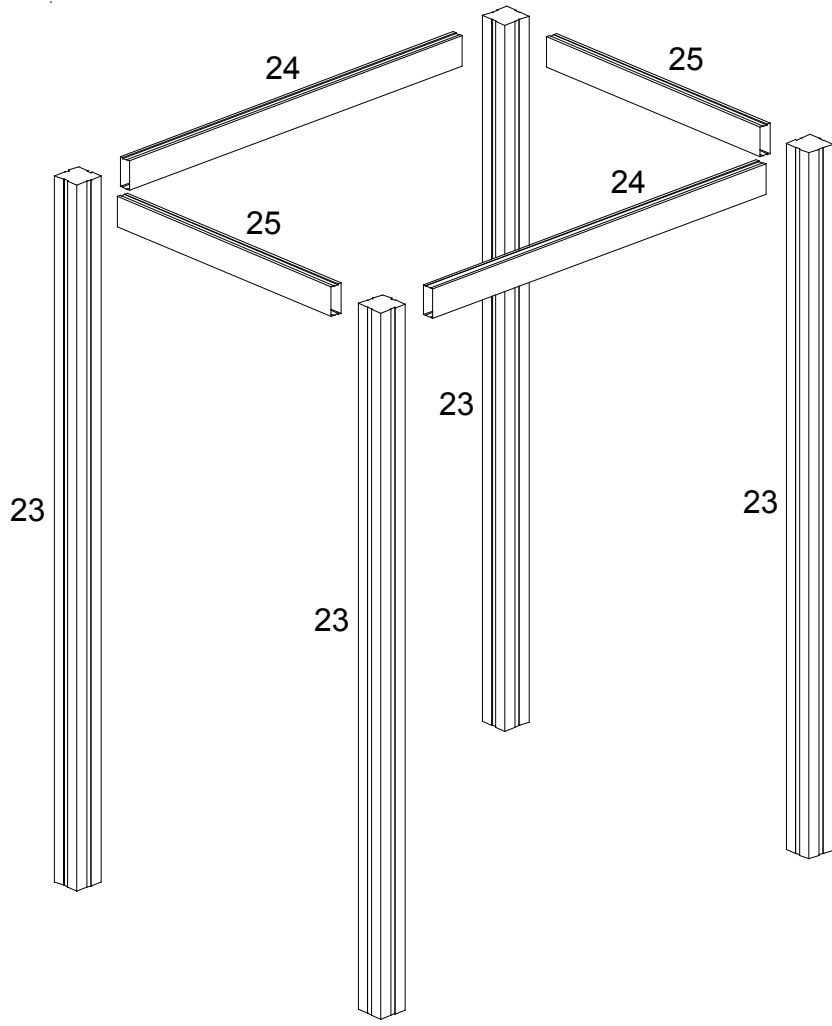

WHEN DISASSEMBLING ALUMINUM EXTRUSION, TIGHTEN ALL SETSCREWS AND LOCKS TO PREVENT LOSS DURING SHIPPING

Item	Qty.	Description
22	2	9"w Shelf Support
34	2	40"h Square Vertical Extrusion
35	2	9"w Horizontal Extrusion
100	1	1.791"h Corner Piece
101	1	1.791"h Corner Piece

- Steps:
- 1) Attach corner pieces [100 and 101] to horizontals [35] as shown.
 - 2) Attach horizontal assemblies [100/35] and [35/101] between [45 and 34] as shown.
 - 3) Attach shelf supports [22] to verticals [34].
 - 4) Velcro laptop shelf atop horizontal supports [22].

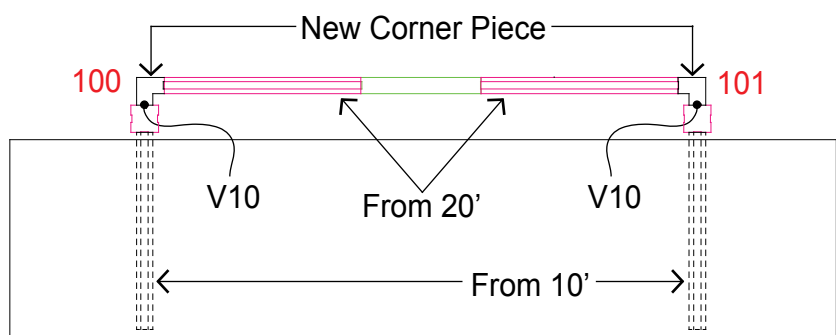

Plan View

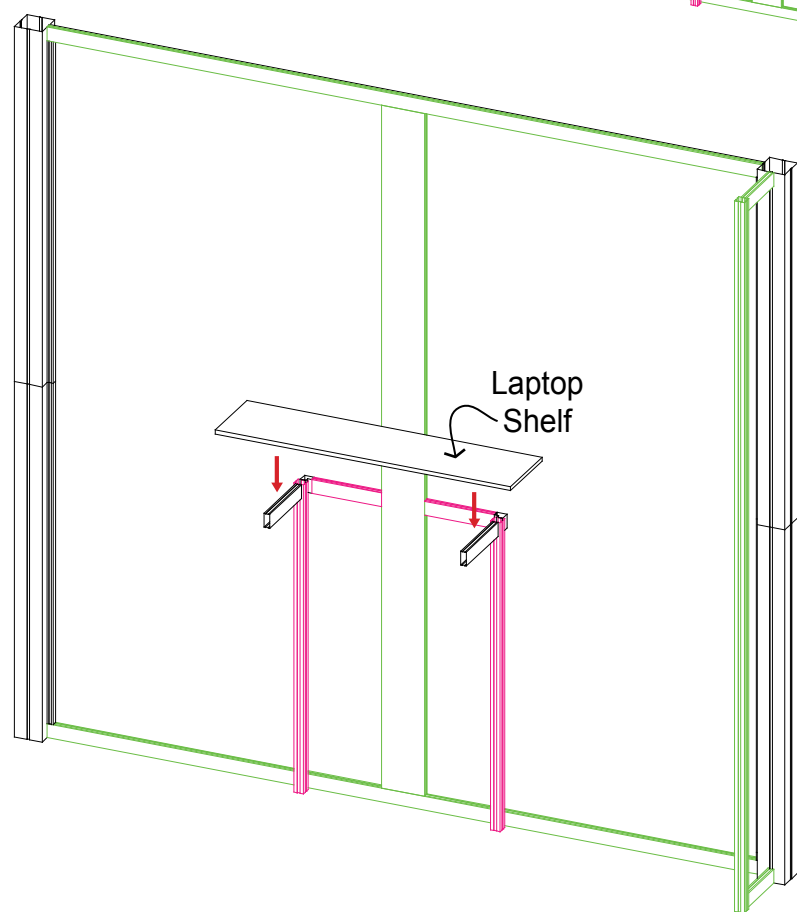
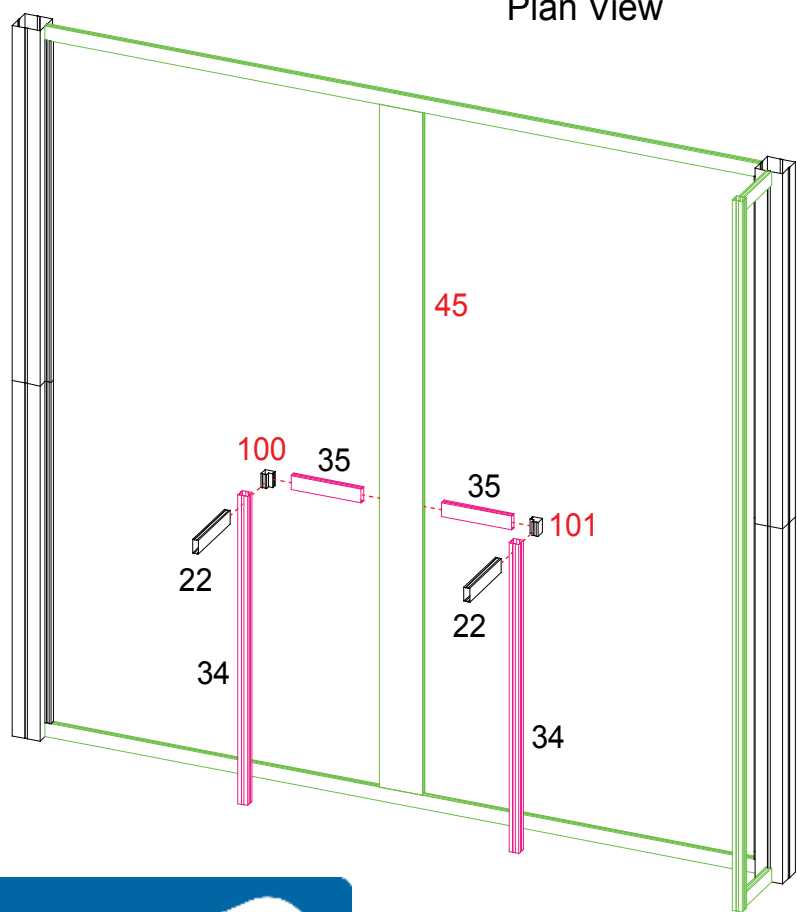
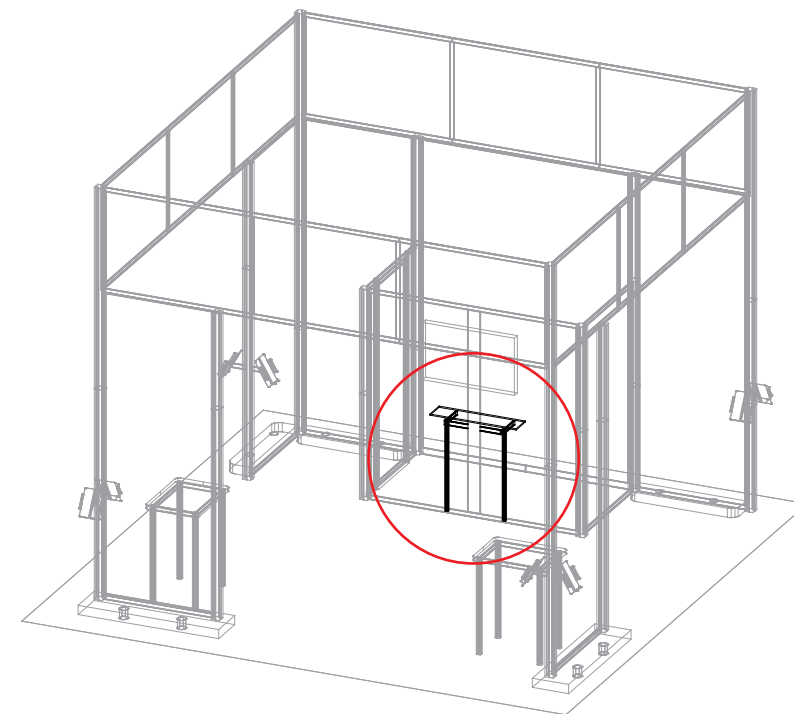
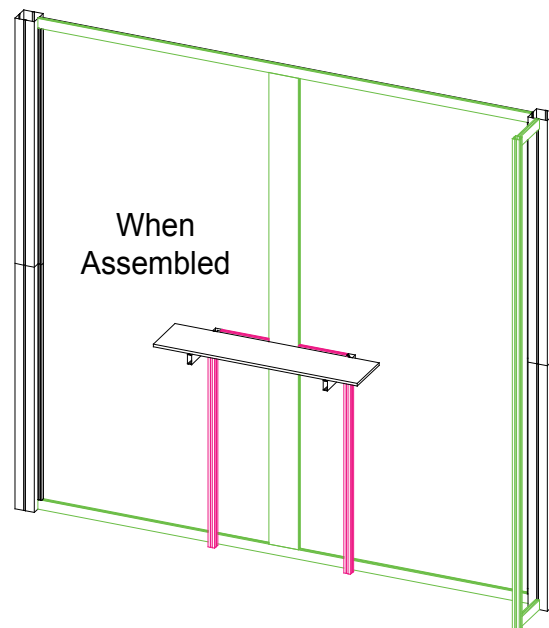

V10 Pressure Screw Attachment

Slide V10 pressure screw between grooves of extrusions. Tighten setscrew to secure pressure in place.



WHEN DISASSEMBLING ALUMINUM EXTRUSION, TIGHTEN ALL SETSCREWS AND LOCKS TO PREVENT LOSS DURING SHIPPING



Level 1

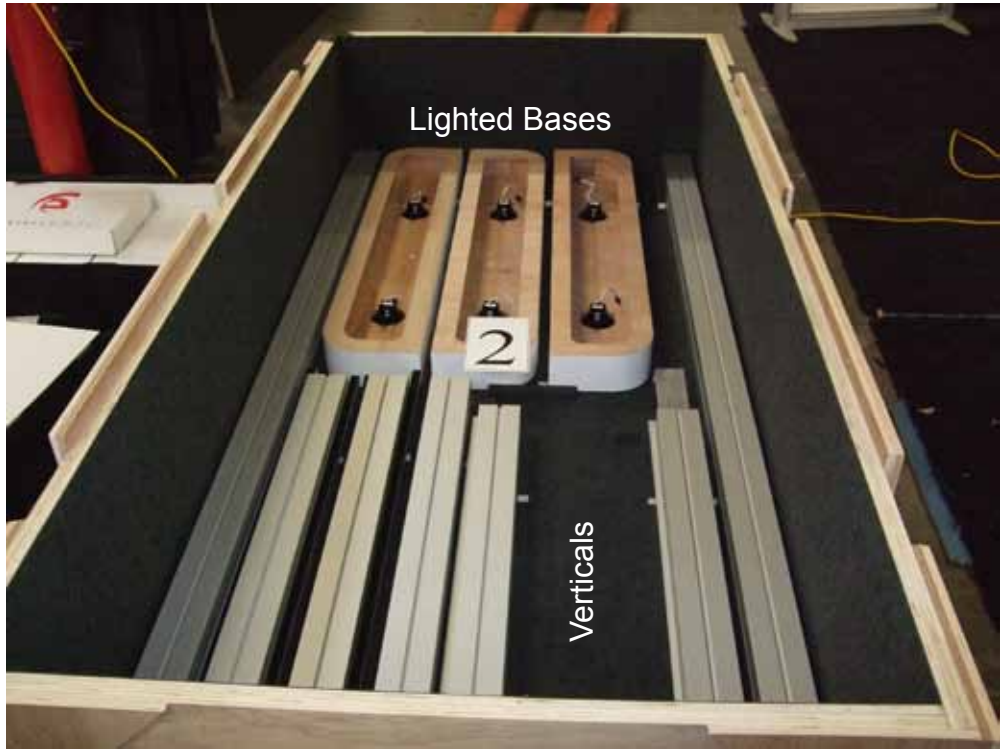

Level 2

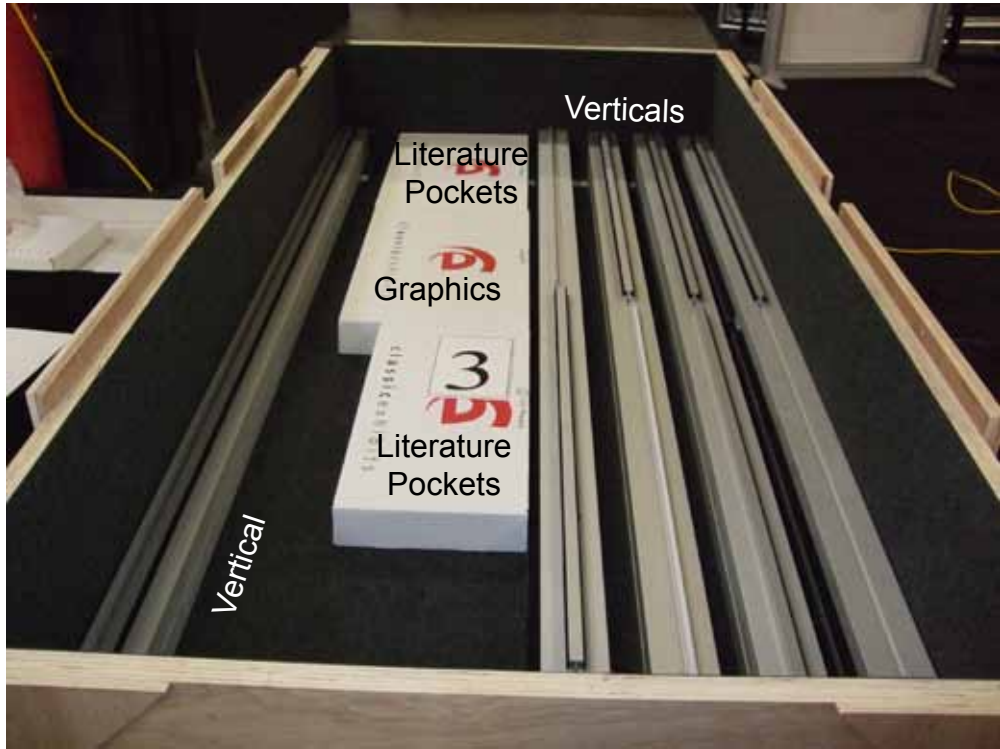

Level 3



Level 4



Level 5



Level 6



WHEN DISASSEMBLING ALUMINUM EXTRUSION, TIGHTEN ALL SETSCREWS AND LOCKS TO PREVENT LOSS DURING SHIPPING