

WHEN DISASSEMBLING ALUMINUM EXTRUSION, TIGHTEN ALL SETSCREWS AND LOCKS TO PREVENT LOSS DURING SHIPPING

visionary™ IDESIGNS

Using Your Setup Instructions

The Visionary Designs Setup Instructions are created specifically for your configuration. They are laid out sequentially, including an exploded view of the entire display, and then a logical series of detailed steps to assemble the main structure and components. We encourage you to study the instructions **before** attempting to assemble your exhibit.

Each page reminds you to tighten the setscrews after disassembling your exhibit to prevent loss of the locks and setscrews (see below in RED). This is **VERY IMPORTANT**.

Cleaning and Packing Your Display

- 1) Use care when cleaning aluminum extrusion or acrylic inserts. Use only non-abrasive cleaners.
- 2) When cleaning laminate inserts or countertops, use mild cleansers and a soft material such as cotton.
- 3) Keep all display components away from extreme heat and long exposure to sunlight to avoid warping and fading.
- 4) Retain all packing material. It will make re-packing much easier and will reduce the likelihood of shipping damage.



The Tool

Most Visionary Designs exhibits can be assembled with the supplied Hex Key Tool. Occasionally, a flat head screwdriver may be required.



Typical Connection

Most horizontal extrusion connections have a patented expandable lock. This lock inserts into the groove of an opposing extrusion. Tightening the lock with the Hex Key Tool expands the lock and creates a strong positive connection.



Typical Connection (cont'd)

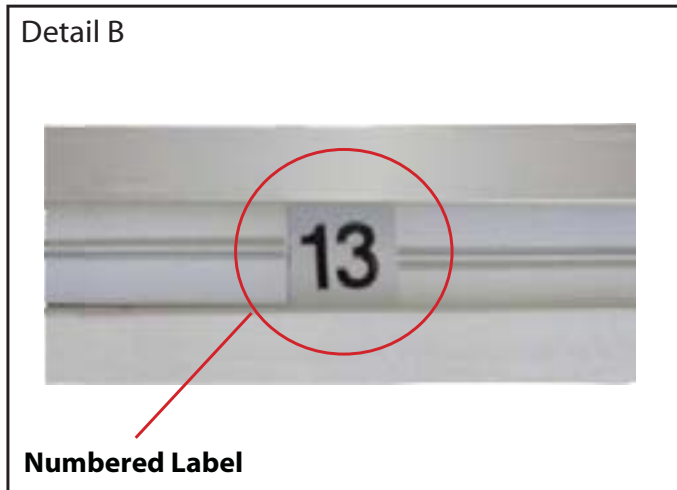

Detail B

Numbered Label

Each extrusion contains a numbered label which corresponds with setup instructions. The label is located within a groove of the extrusion (when possible). With Visionary Designs the labels contain Black numbers unless otherwise specified.



Detail C

Horizontal Inline Connection (remove only one setscrew)

Remove only (1) setscrew when disassembling. Replace setscrew in extrusion after assembling it. Before packing, replace setscrew in extrusion to avoid losing it.

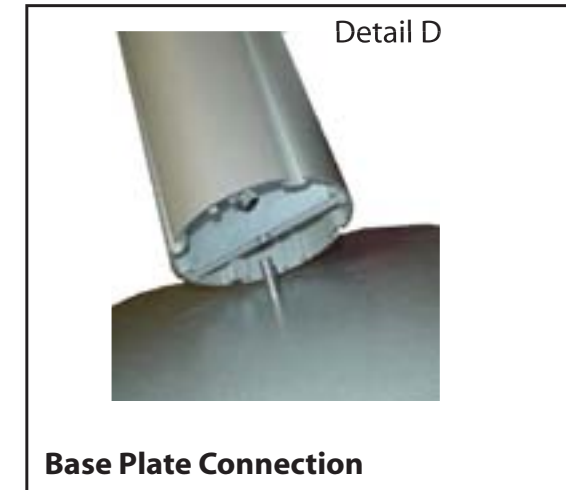

Detail D

Base Plate Connection

Attach base plate to round or square vertical extrusion using the bolt provided. Be careful not to strip the threads.

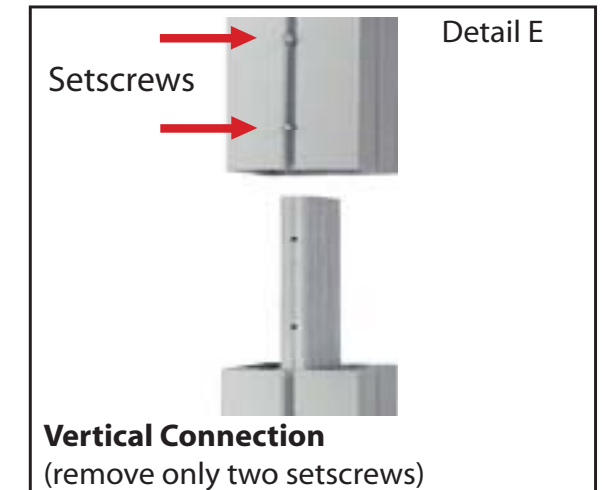

Detail E

Vertical Connection
(remove only two setscrews)

When vertical extrusions are packed in portable cases rather than crates or tubs, they must be broken down into smaller sections which then require assembly.

Remove only (2) setscrews when disassembling. Replace setscrews in extrusion after assembling it. Before packing, replace setscrews in extrusion to avoid losing them.

WHEN DISASSEMBLING ALUMINUM EXTRUSION, TIGHTEN ALL SETSCREWS AND LOCKS TO PREVENT LOSS DURING SHIPPING

866.652.2100

Item #	Qty.	Description
1	2	Base Plate
2/3	1/1	42" h S40 Vertical Extrusion w/ A10 Clamps
4/5	4/4	42.125" h S40 Vertical Extrusion
6/7	1/1	42" h S40 Vertical Extrusion w/ A10 Clamps
8	2	24" w Z45 Horizontal Extrusion
9	4	16" w Z45 Horizontal Extrusion
10	2	10" w Z45 Horizontal Extrusion
11	2	22" w Z45 Horizontal Extrusion
12	1	27" w Z45 Horizontal Extrusion
13a/13b	2/2	34.89" w Z45 Horizontal Extrusion
14	2	22" w Z45 Horizontal Extrusion
15	1	27" w Z45 Horizontal Extrusion
16	6	20.29" h S40 Vertical Extrusion

- Steps:
- 1) Attach vertical extrusions [2,6] to base plates [1] with cam locks.
 - 2) Connect lower horizontal extrusions [8-12] between verticals [2,4,6] as shown.
 - 3) Connect vertical extrusions [3,5,7] to verticals [2,4,6] as shown.
 - 4) Connect horizontal extrusions [13a,13b].
 - 5) Connect upper verticals with horizontals [13a/13b,14,15] as shown.
 - 6) Attach graphics to velcro at the back of the assembled backwall.

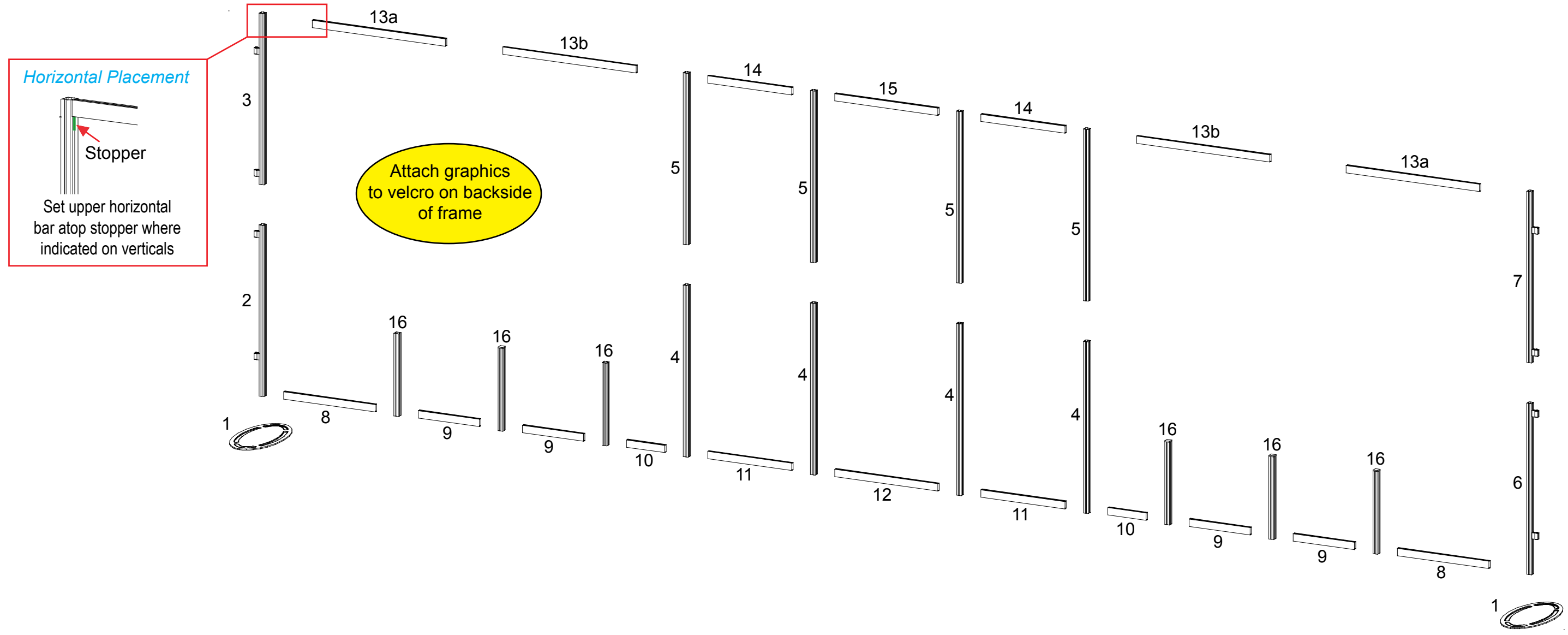
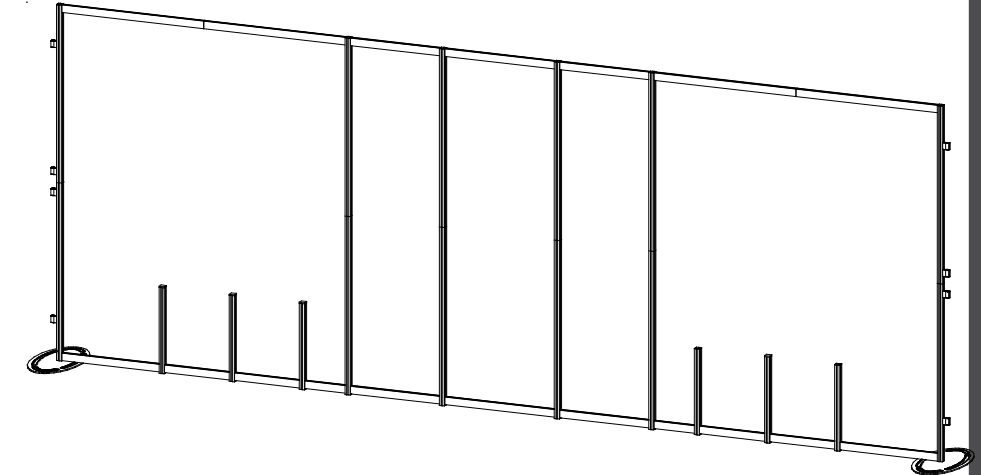

WHEN DISASSEMBLING ALUMINUM EXTRUSION, TIGHTEN ALL SETSCREWS AND LOCKS TO PREVENT LOSS DURING SHIPPING

866.652.2100

Item #	Qty.	Description
17	6	20.29" h S40 Vertical Extrusion
18	2	42.125" h S40 Vertical Extrusion
19	2	39" h S40 Vertical Extrusion
20	22	18" w Shelf Support
20a	4	18" w Ceiling Support
20b	10	18" w Horizontal Extrusions

- Steps:
- 1) Connect shelf supports [20,20a,20b] to backwall as shown for both left and right sides. (Stoppers indicate where to position shelf supports)
 - 2) Connect vertical extrusions [18,19].
 - 3) Connect vertical extrusions [17,18/19] to shelf supports [20,20a,20b].
 - 4) Secure plex shelves to supports using screw caps.

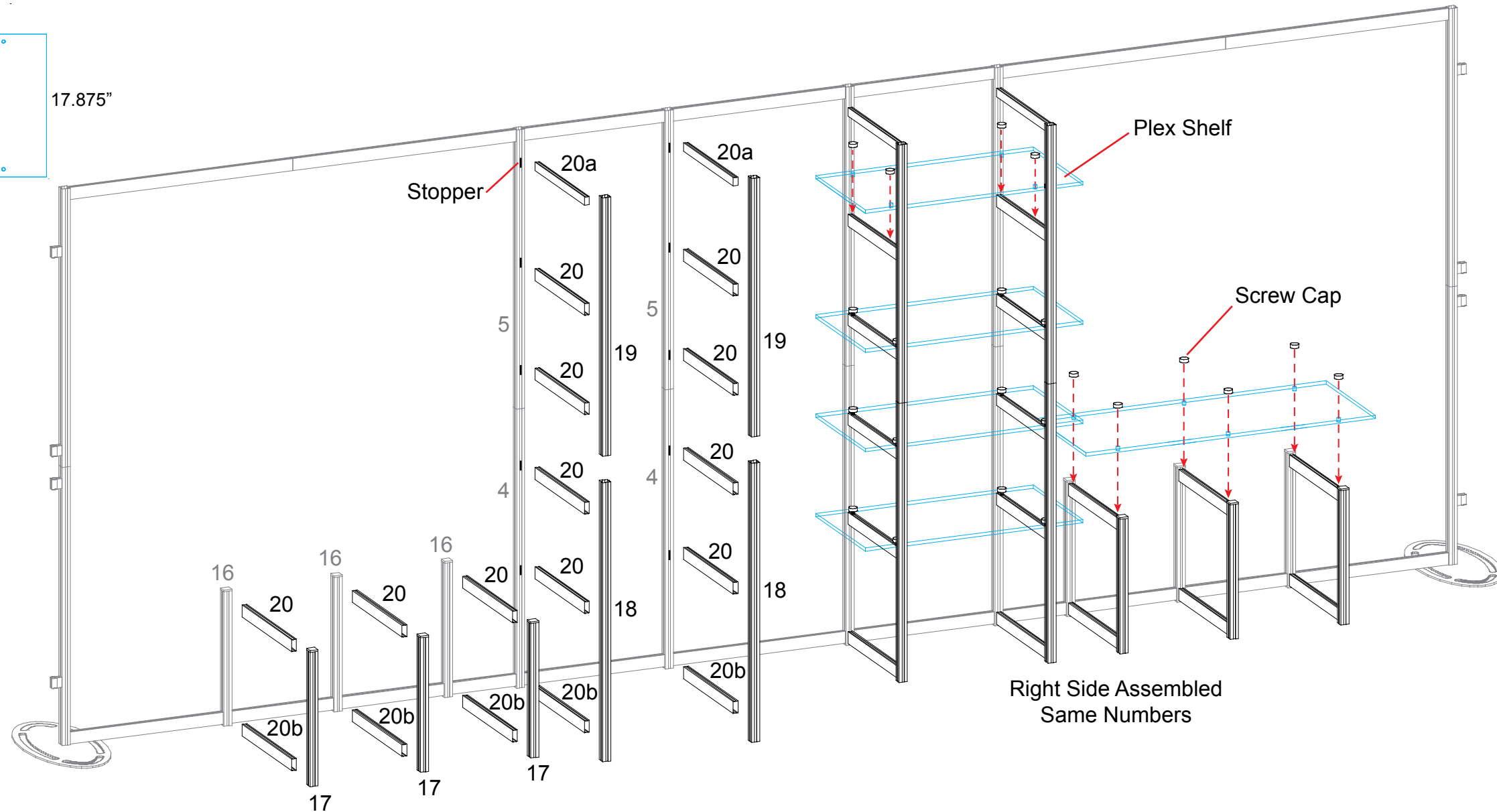
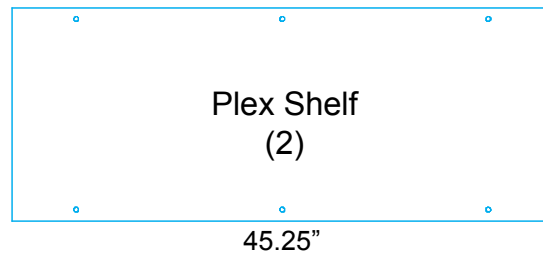
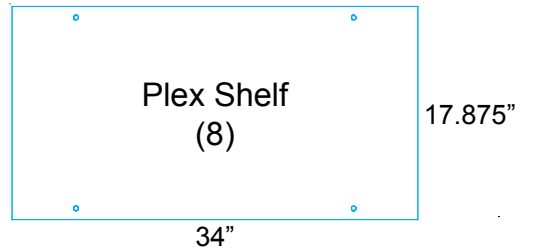
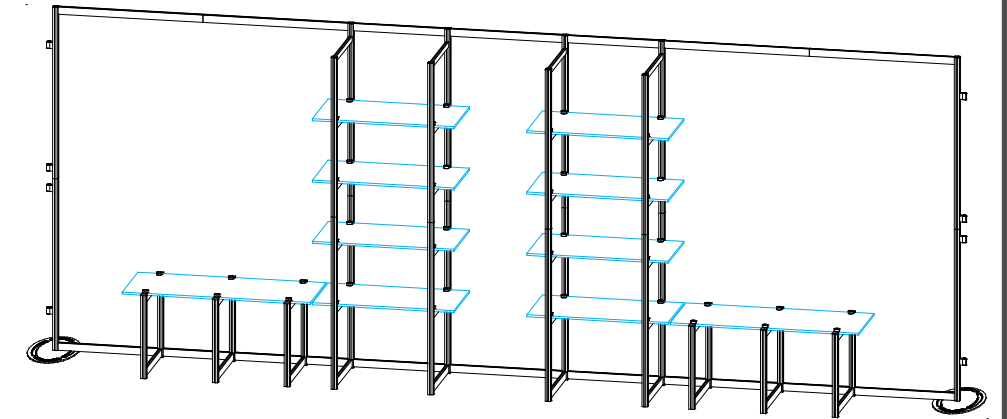

WHEN DISASSEMBLING ALUMINUM EXTRUSION, TIGHTEN ALL SETSCREWS AND LOCKS TO PREVENT LOSS DURING SHIPPING

866.652.2100

Steps:

- 1) Assembled middle section of ceiling according to detail provided.
- 2) Attach end sections of ceiling to middle section with screws.
- 3) Attach assembled ceiling to top of shelves with screws.
- 4) Attach lights to assembled backwall.
- 5) Attach wings to A10 clamps.
- 6) Attach monitor mounts to connectors in backwall with screws.

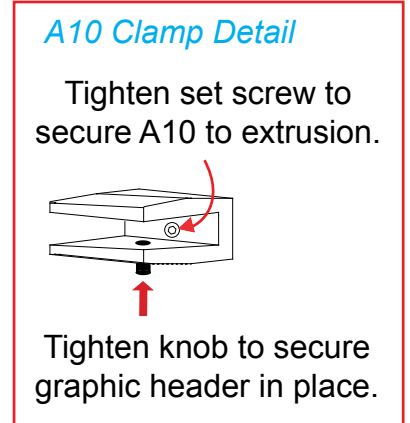
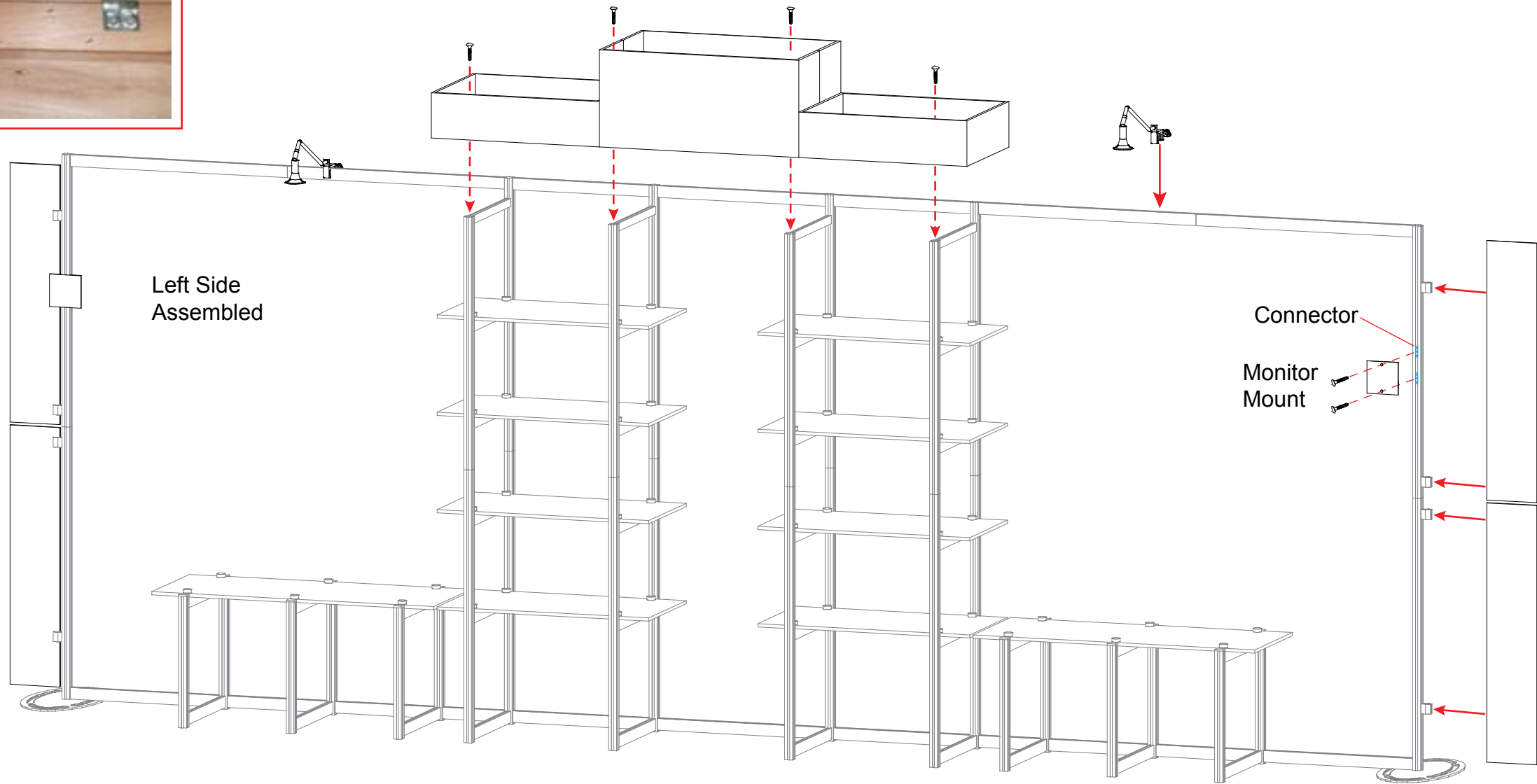
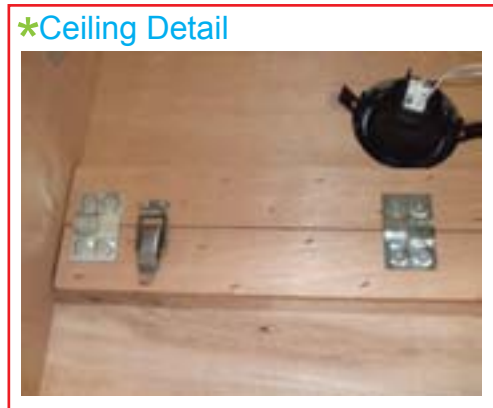
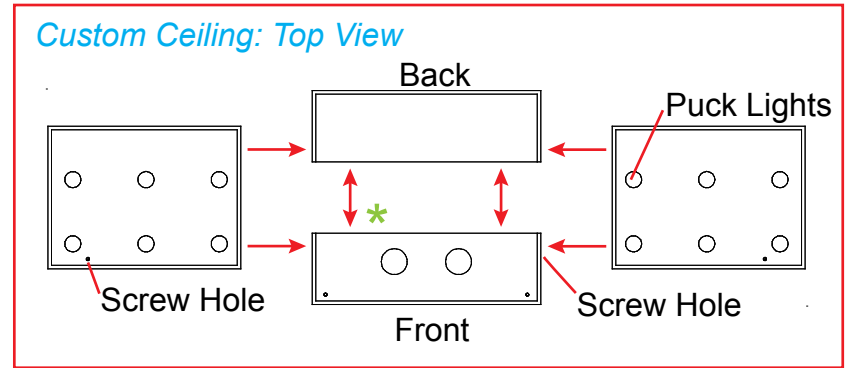
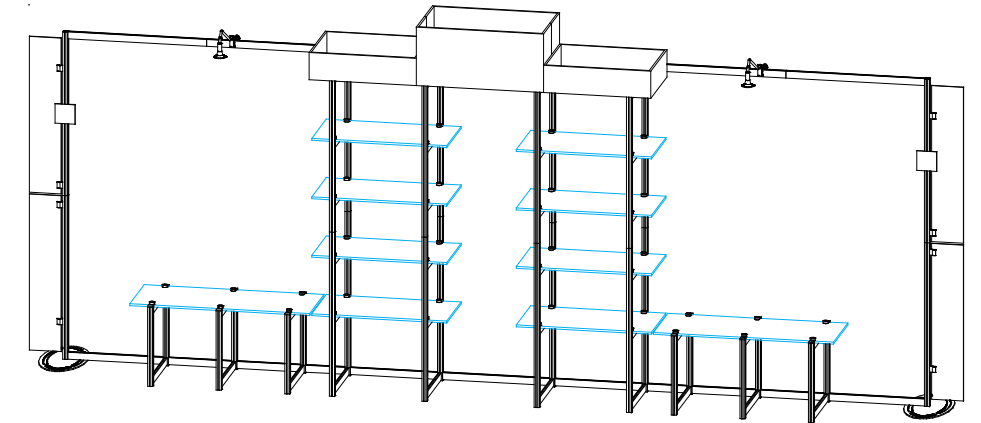

WHEN DISASSEMBLING ALUMINUM EXTRUSION, TIGHTEN ALL SETSCREWS AND LOCKS TO PREVENT LOSS DURING SHIPPING

866.652.2100

Item #	Qty.	Description
21	1	42" h Vertical Extrusion
22	1	42" h Vertical Extrusion
23	1	42" h Vertical Extrusion
24	1	42" h Vertical Extrusion
25	4	30" w Horizontal Extrusion
26	4	10" w Horizontal Extrusion

- Steps:
- 1) Connect vertical extrusions [21-24] with horizontal extrusions [25,26] as shown.
 - 2) Starting with the lowest shelf, set shelves on pins located in vertical extrusions.
 - 3) Place counter top on assembled shelves.

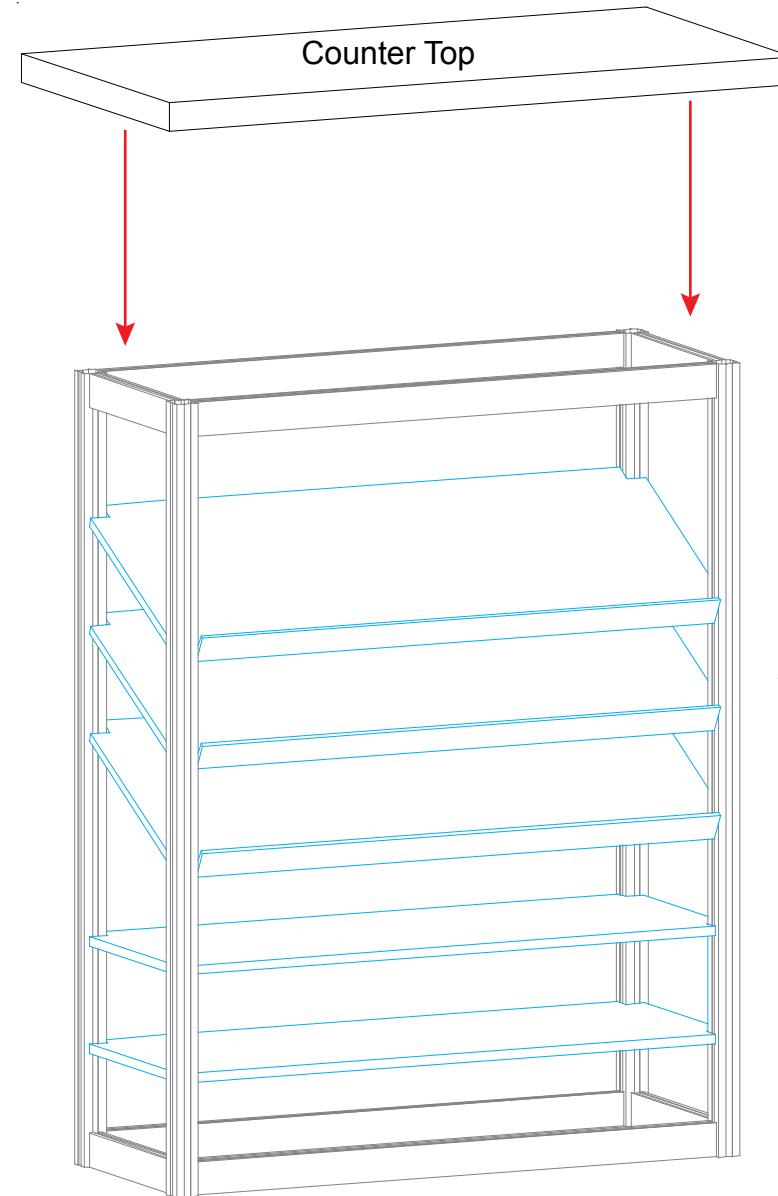
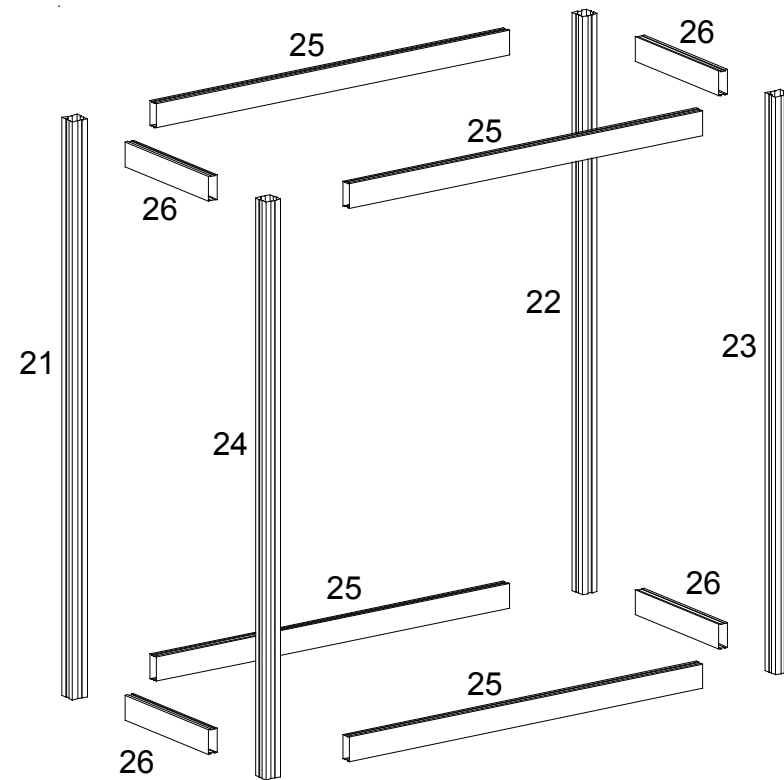
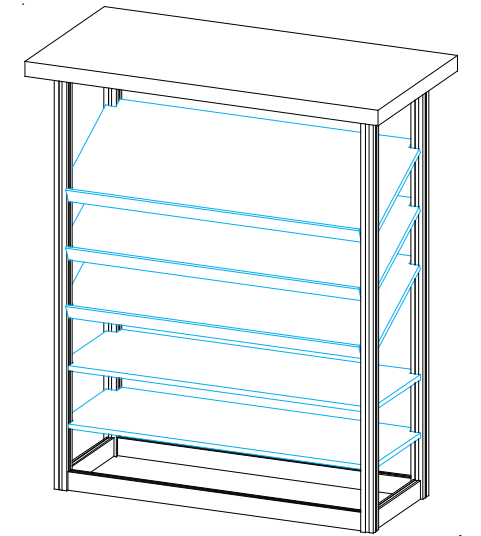

Angled Shelves

Horizontal Shelves

WHEN DISASSEMBLING ALUMINUM EXTRUSION, TIGHTEN ALL SETSCREWS AND LOCKS TO PREVENT LOSS DURING SHIPPING

866.652.2100



Using Your Setup Instructions

The Aero Overhead Sign Setup Instructions are created specifically for your configuration. They include an exploded view of the frame which is sequentially numbered. We encourage you to study the instructions before attempting to assemble your exhibit.

Connections are kept very simple: no tools. Everything assembles with push-button connectors and pre-connected horizontal sections.

Cleaning and Packing Your Display

- 1) Use care when cleaning aluminum extrusion or acrylic inserts. Use only non-abrasive cleaners.
- 2) Retain all packing material. It will make re-packing much easier and will reduce the likelihood of shipping damage.

Steps:

- 1) Connect pieces together in numerical order as shown.
- 2) Attach base plates with screws.
- 3) Apply graphics to assembled stand.
- 4) Attach shelves to A10 clamps.

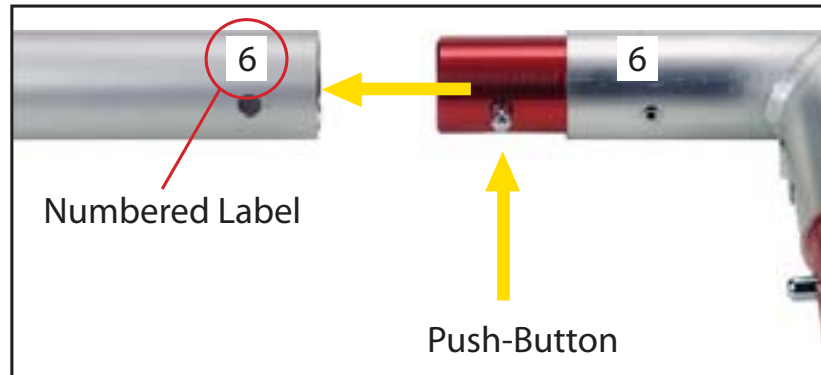
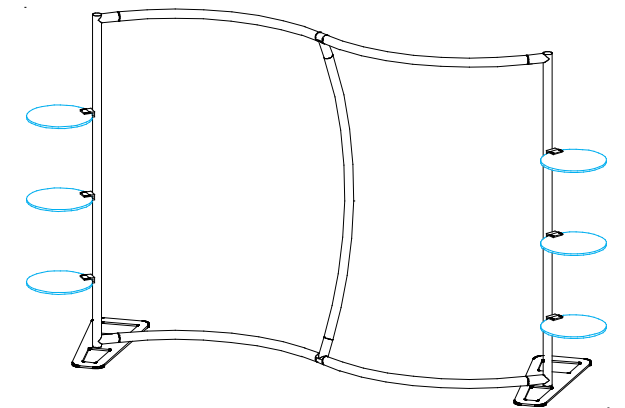

Connections are made by holding the button down and sliding the red tube into opposing tube until the connection is made. To disassemble push button and pull or twist extrusions apart.

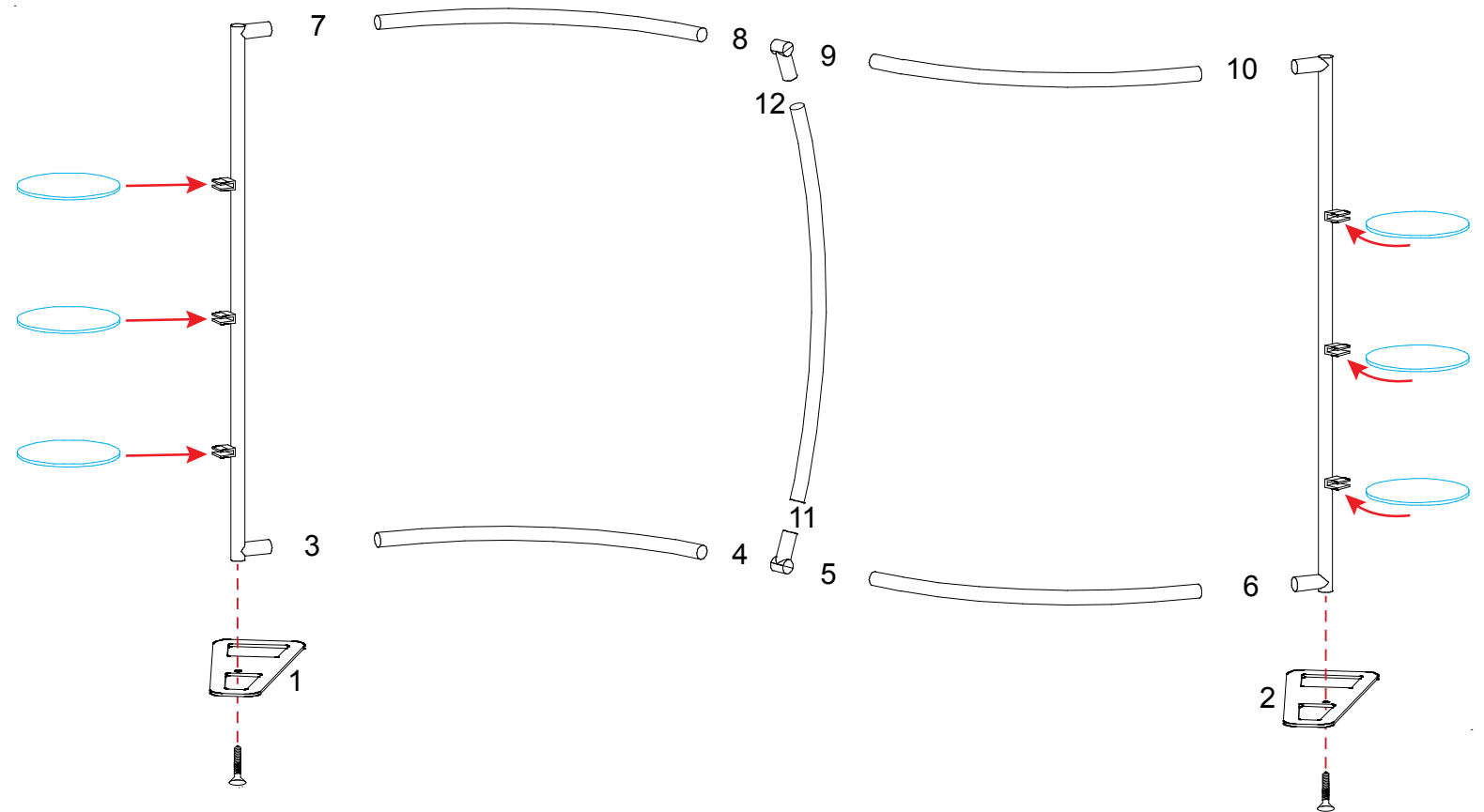
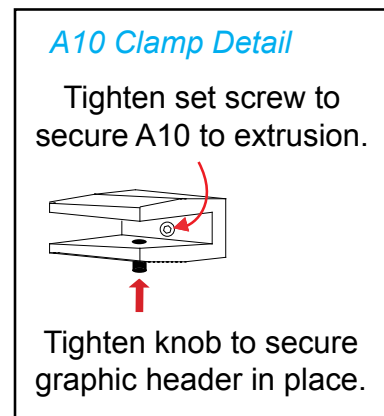
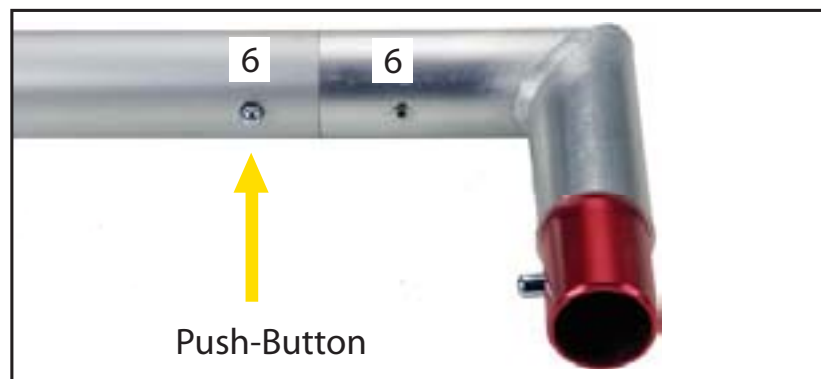

WHEN DISASSEMBLING ALUMINUM EXTRUSION, TIGHTEN ALL SETSCREWS AND LOCKS TO PREVENT LOSS DURING SHIPPING

Top View

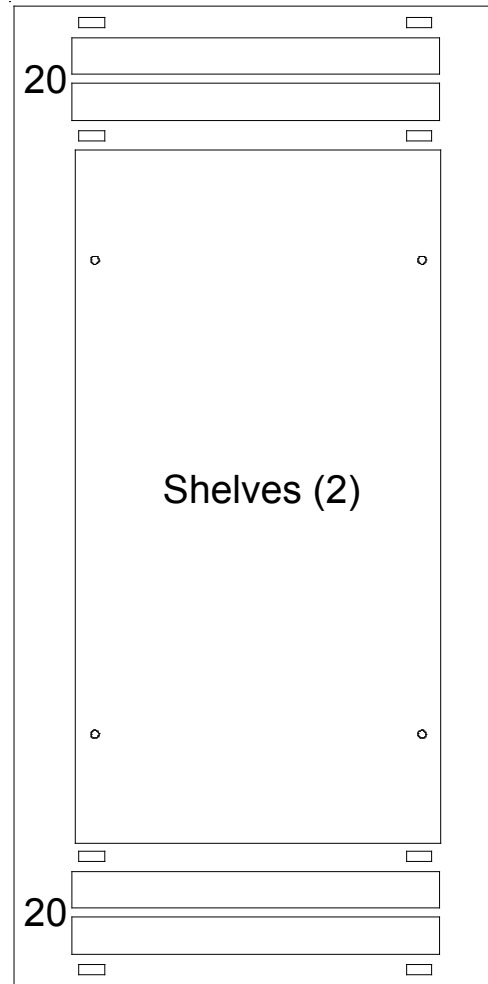

Level 1

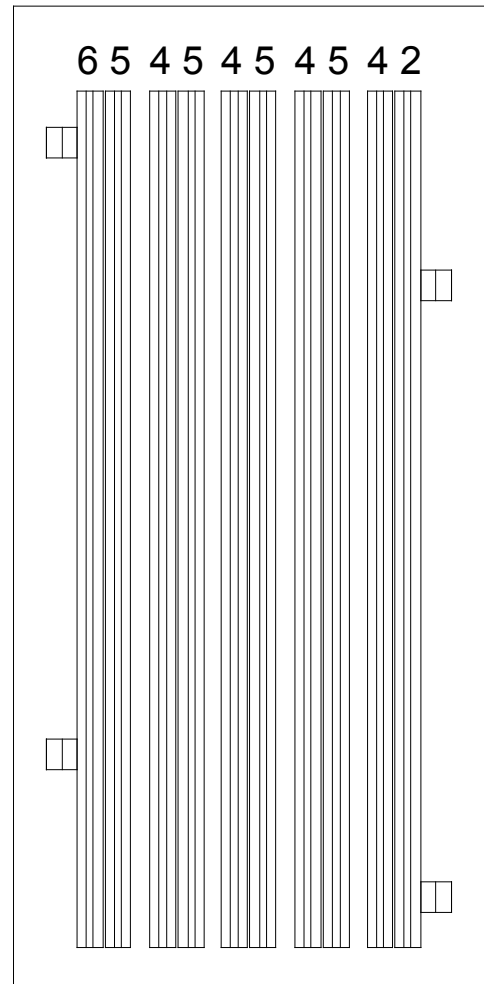

Level 2

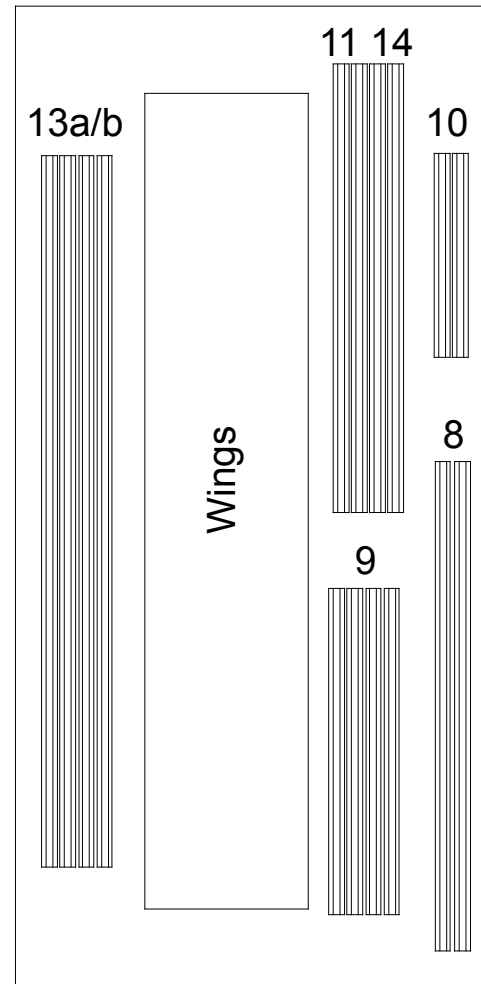

Level 3

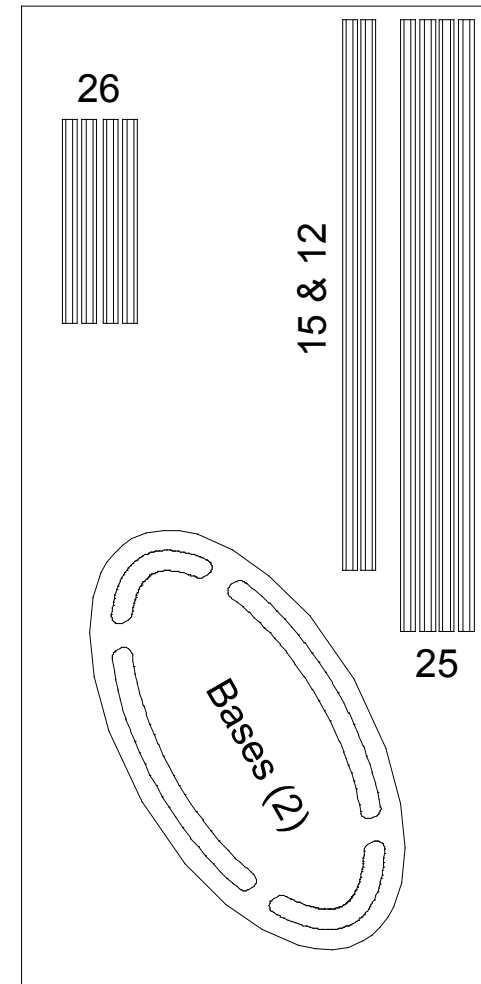

Level 4

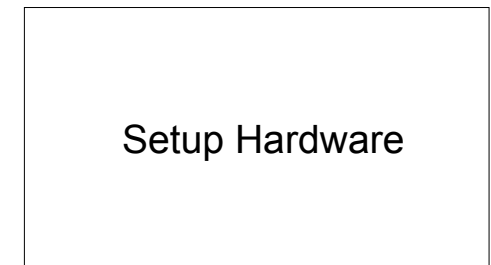

WHEN DISASSEMBLING ALUMINUM EXTRUSION, TIGHTEN ALL SETSCREWS AND LOCKS TO PREVENT LOSS DURING SHIPPING

Top View

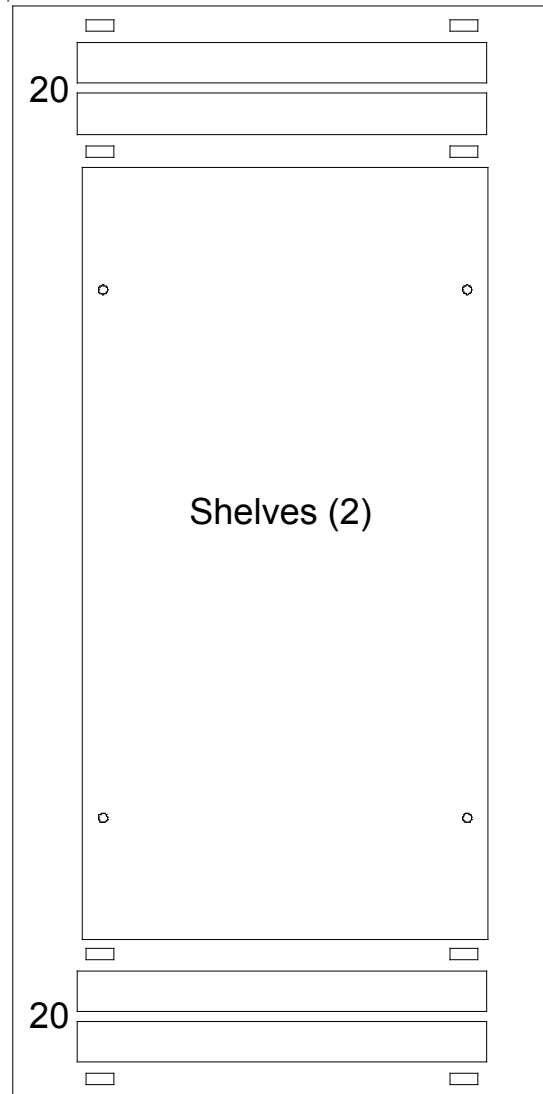

Level 1

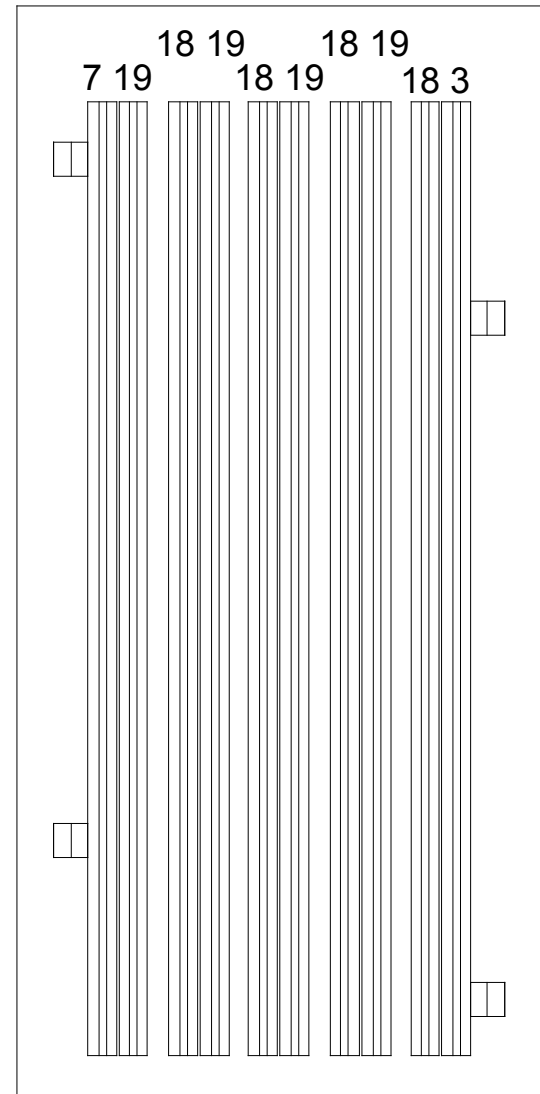

Level 2

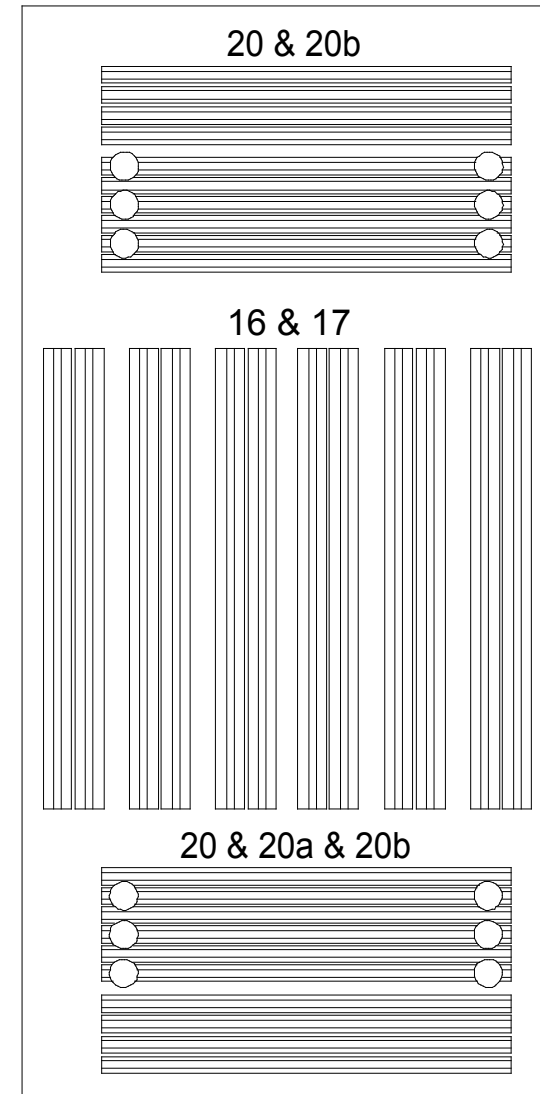

Level 3

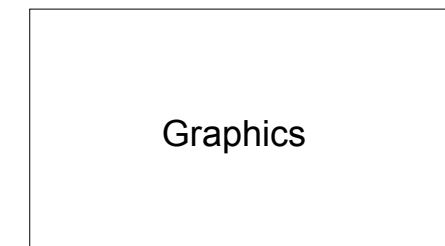
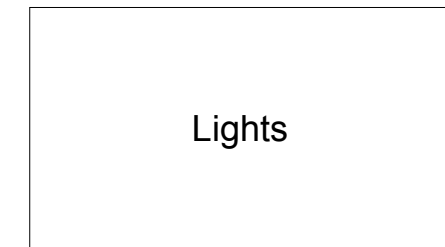

WHEN DISASSEMBLING ALUMINUM EXTRUSION, TIGHTEN ALL SETSCREWS AND LOCKS TO PREVENT LOSS DURING SHIPPING

Top View

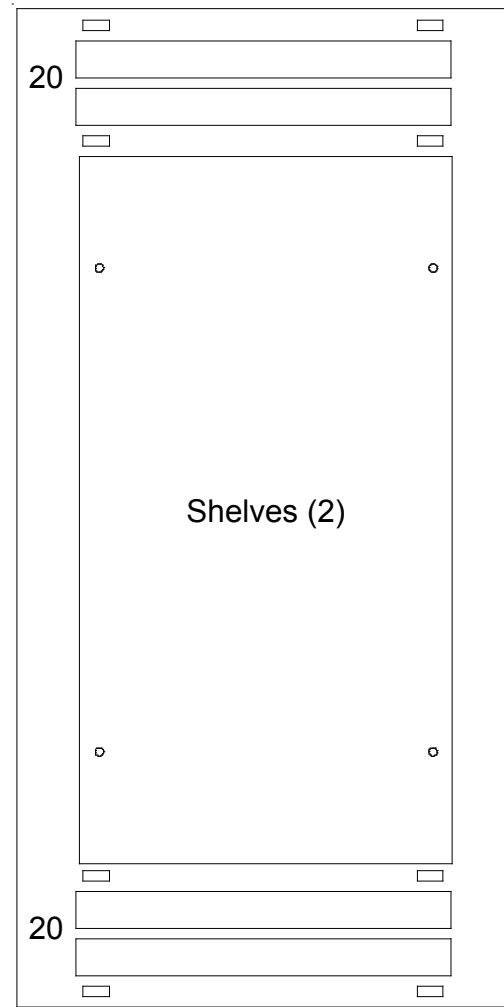

Level 1

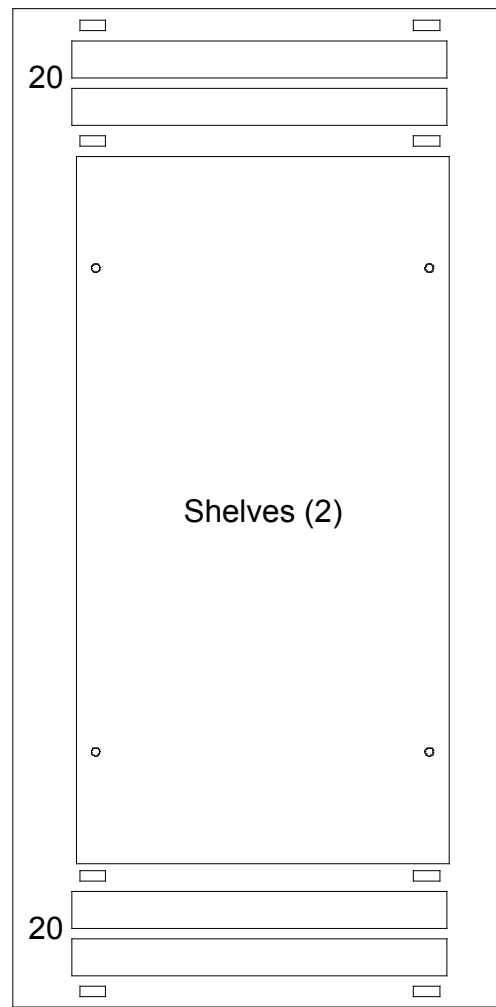

Level 2

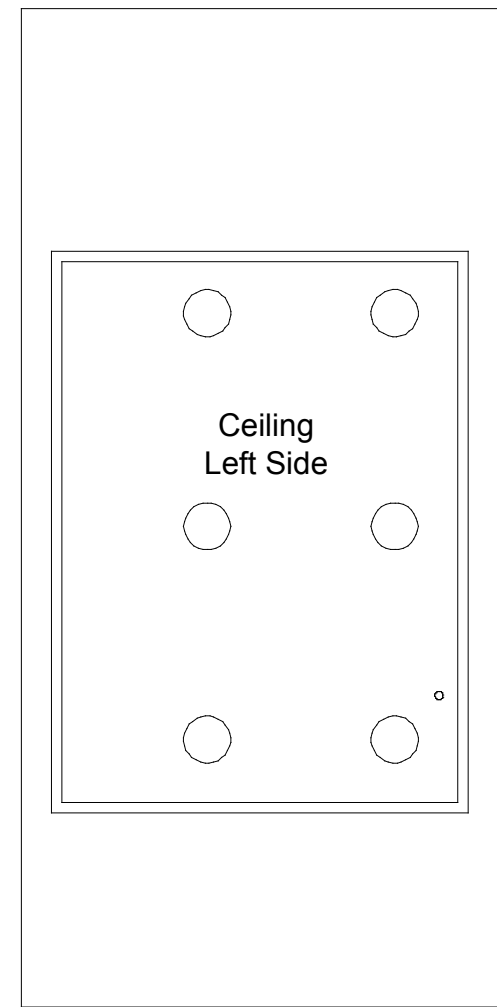

Level 3

WHEN DISASSEMBLING ALUMINUM EXTRUSION, TIGHTEN ALL SETSCREWS AND LOCKS TO PREVENT LOSS DURING SHIPPING

Top View

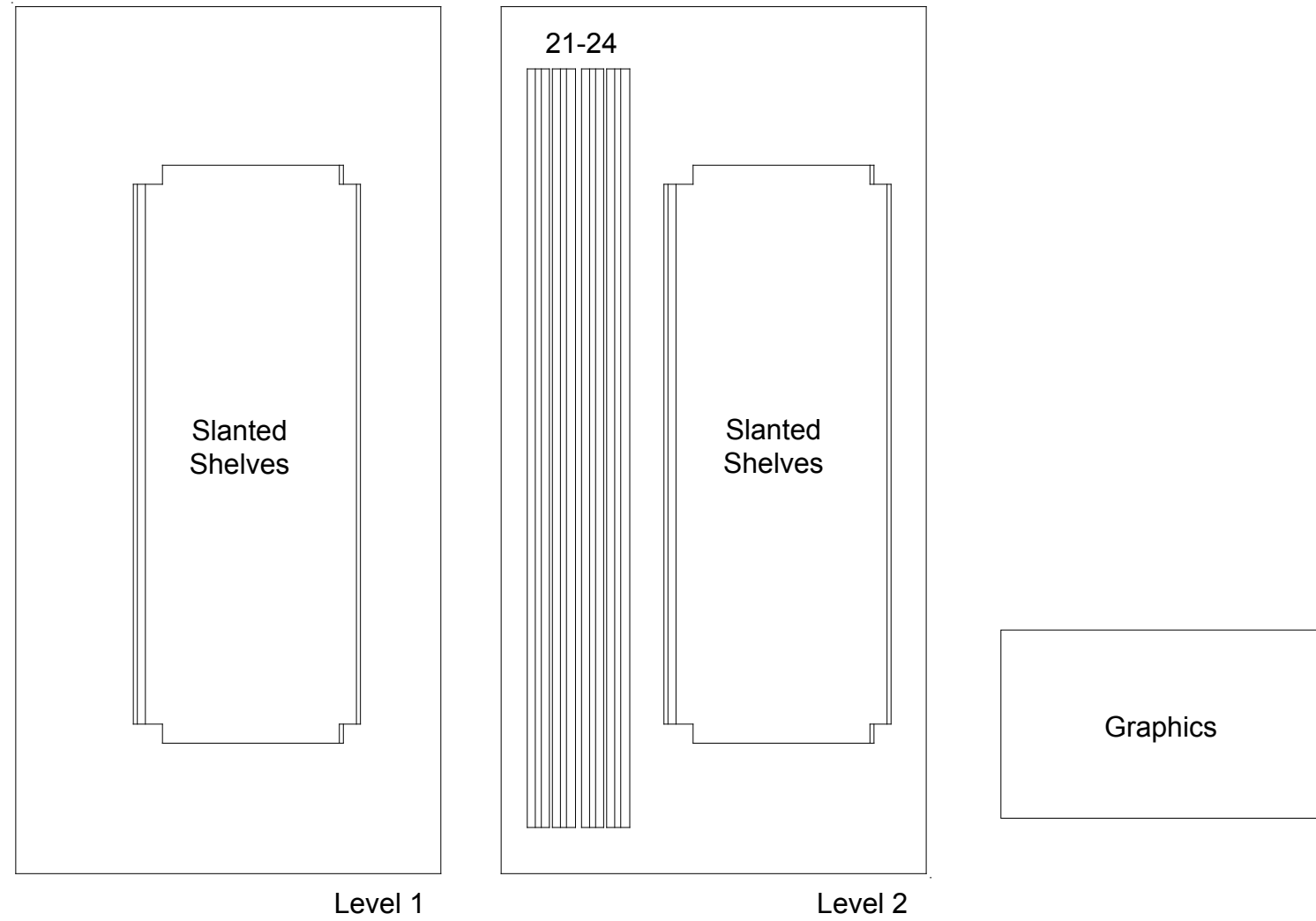

WHEN DISASSEMBLING ALUMINUM EXTRUSION, TIGHTEN ALL SETSCREWS AND LOCKS TO PREVENT LOSS DURING SHIPPING

Top View

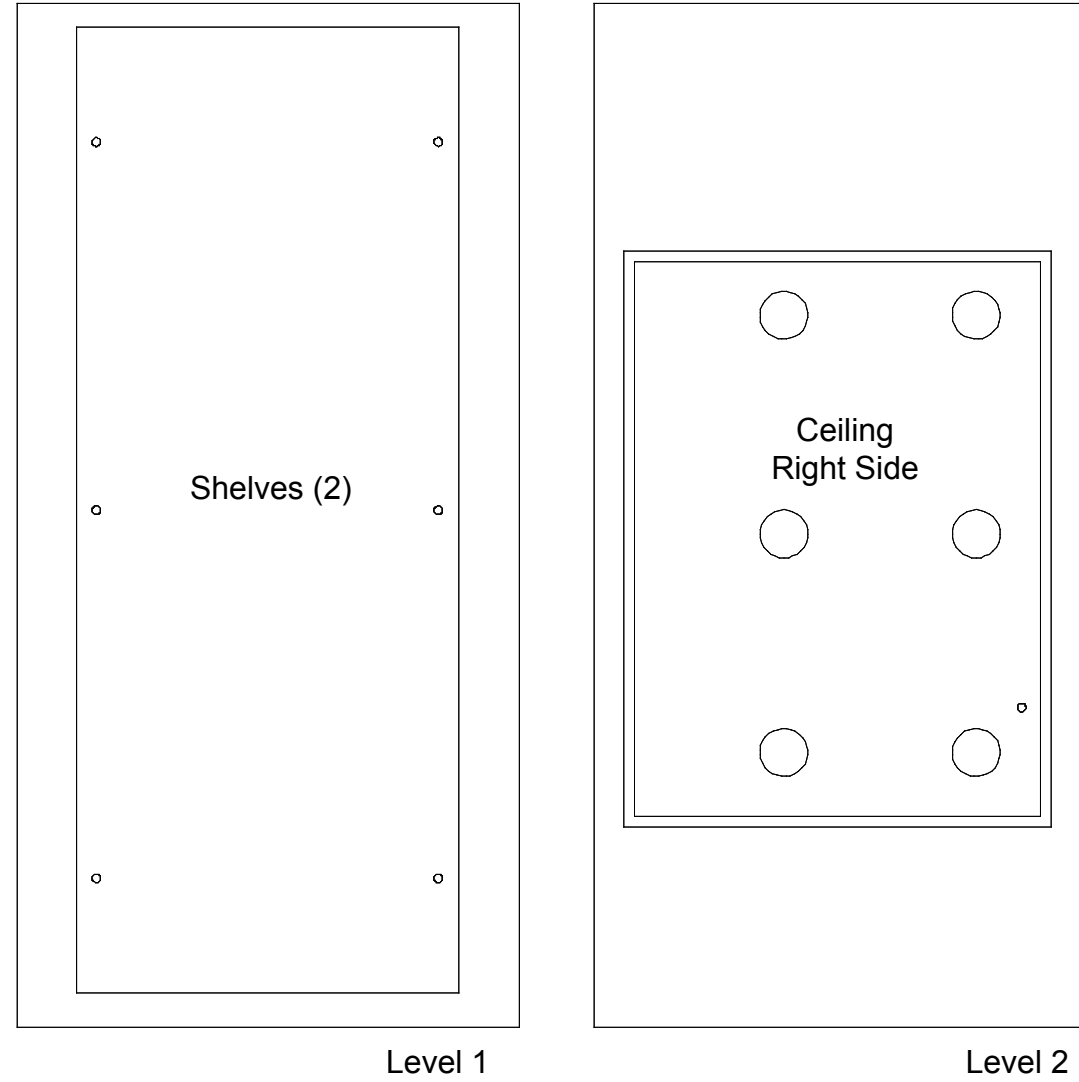

WHEN DISASSEMBLING ALUMINUM EXTRUSION, TIGHTEN ALL SETSCREWS AND LOCKS TO PREVENT LOSS DURING SHIPPING

Top View

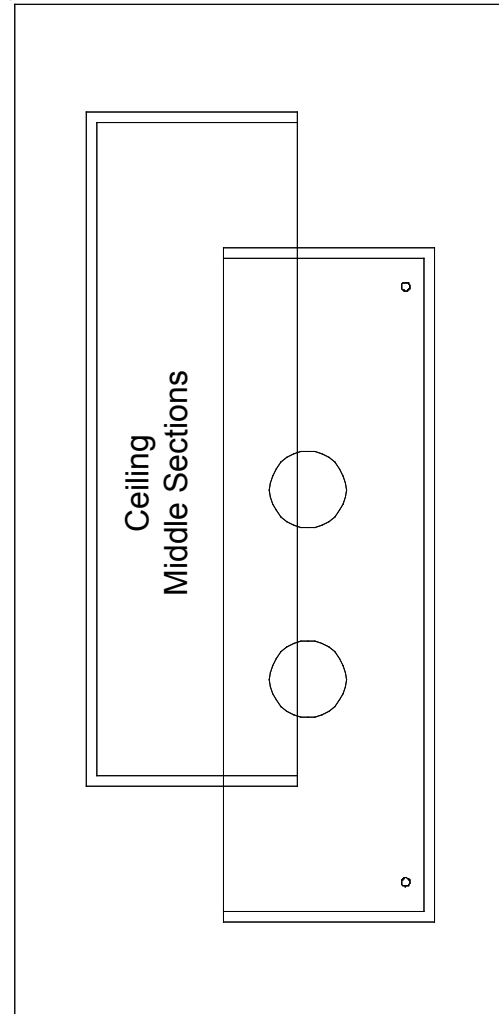

Level 1

WHEN DISASSEMBLING ALUMINUM EXTRUSION, TIGHTEN ALL SETSCREWS AND LOCKS TO PREVENT LOSS DURING SHIPPING