

# visionary™ DESIGNS

## Using Your Setup Instructions

The Visionary Designs Setup Instructions are created specifically for your configuration. They are laid out sequentially, including an exploded view of the entire display, and then a logical series of detailed steps to assemble the main structure and components. We encourage you to study the instructions **before** attempting to assemble your exhibit.

Each page reminds you to tighten the setscrews after disassembling your exhibit to prevent loss of the locks and setscrews (see below in RED). This is **VERY IMPORTANT**.

## Cleaning and Packing Your Display

- 1) Use care when cleaning aluminum extrusion or acrylic inserts. Use only non-abrasive cleaners.
- 2) When cleaning laminate inserts or countertops, use mild cleansers and a soft material such as cotton.
- 3) Keep all display components away from extreme heat and long exposure to sunlight to avoid warping and fading.
- 4) Retain all packing material. It will make re-packing much easier and will reduce the likelihood of shipping damage.



**The Tool**

Most Visionary Designs exhibits can be assembled with the supplied Hex Key Tool. Occasionally, a flat head screwdriver may be required.



Detail A

**Typical Connection**



**Typical Connection (cont'd)**

Most horizontal extrusion connections have a patented expandable lock. This lock inserts into the groove of an opposing extrusion. Tightening the lock with the Hex Key Tool expands the lock and creates a strong positive connection.

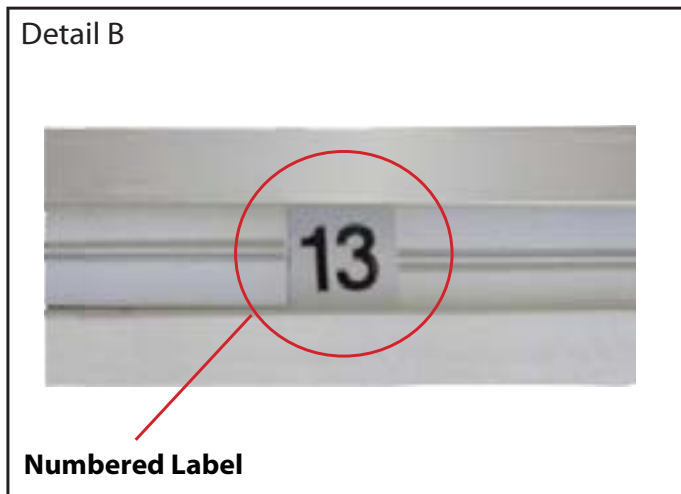

Detail B

**Numbered Label**

Each extrusion contains a numbered label which corresponds with setup instructions. The label is located within a groove of the extrusion (when possible). With Visionary Designs the labels contain Black numbers unless otherwise specified.



Detail C

**Horizontal Inline Connection** (remove only one setscrew)

Remove only (1) setscrew when disassembling. Replace setscrew in extrusion after assembling it. Before packing, replace setscrew in extrusion to avoid losing it.

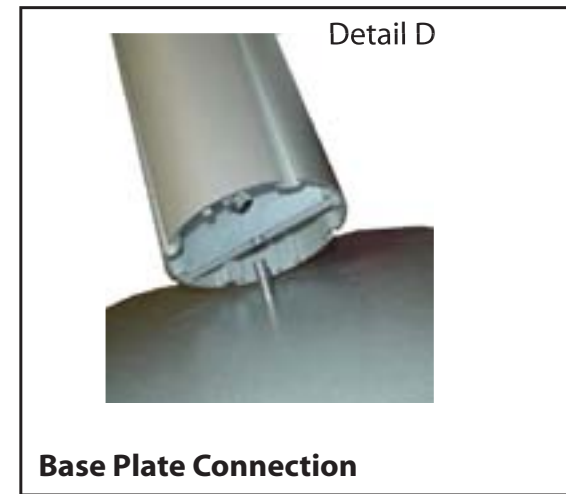

Detail D

**Base Plate Connection**

Attach base plate to round or square vertical extrusion using the bolt provided. Be careful not to strip the threads.

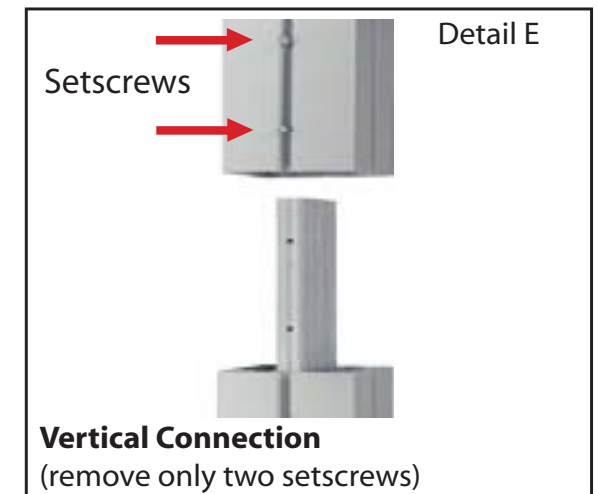

Detail E

**Vertical Connection**  
(remove only two setscrews)

When vertical extrusions are packed in portable cases rather than crates or tubs, they must be broken down into smaller sections which then require assembly.

Remove only (2) setscrews when disassembling. Replace setscrews in extrusion after assembling it. Before packing, replace setscrews in extrusion to avoid losing them.

**WHEN DISASSEMBLING ALUMINUM EXTRUSION, TIGHTEN ALL SETSCREWS AND LOCKS TO PREVENT LOSS DURING SHIPPING**

## Graphic: To Ensure Proper Fit

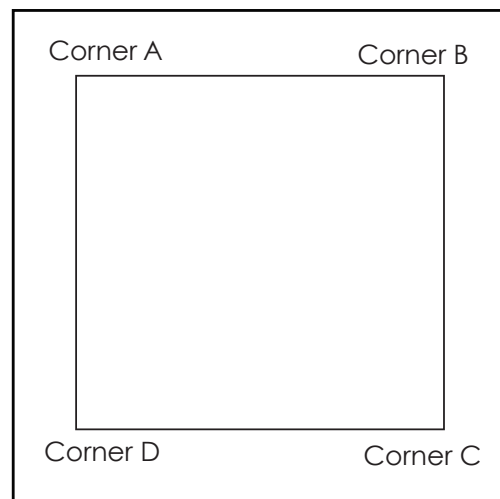

It is important to first insert graphic into each alternater corner then to the sides of the frame.  
If this is not done, graphic will not fit into the frame correctly.



**Step 1**  
Insert corner A.  
Turn edge of graphic so silicon welt is perpendicular to face of graphic.  
Insert narrow side of welt with fabric to outside into the channel.  
Repeat for other side of this corner.



**Step 2**  
Repeat Step 1 for opposite corner C, then insert corner B, followed by corner corner D, to complete the installation of the corners.



**Step 3**  
Once all corners are inserted, press one silicon edge into channel from corners and work toward the center.  
Make sure welt is fully inserted into channel. Continue until all sides are done. Smooth out edges of graphic.

## Graphic Removal



To remove the graphic from the frame, locate the fabric pull tab.  
Gently pull up on the tab to remove the fabric.

WHEN DISASSEMBLING ALUMINUM EXTRUSION, TIGHTEN ALL SETSCREWS AND LOCKS TO PREVENT LOSS DURING SHIPPING

866.652.2100

Item	Qty.	Description	Item	Qty.	Description
1/1a	2/2	Base Plate	10	1	47.875" S44 Vertical Extrusion
2	1	47.875" TSP46 Vertical Extrusion	11	1	47.875" S44 Vertical Extrusion
3	1	47.875" TSP46 Vertical Extrusion	12	1	47.875" TSP46 Vertical Extrusion
4	1	47.875" TSP46/S44 Vertical Extrusion	13	1	47.875" TSP46 Vertical Extrusion
5	1	47.875" TSP46/S44 Vertical Extrusion	14a/14b	1/1	48" TSP46 Horizontal Extrusion
6	1	47.875" S44 Vertical Extrusion	15a/15b	1/1	48" TSP46 Horizontal Extrusion
7	1	47.875" S44 Vertical Extrusion	16a/16b	1/1	48" TSP46 Horizontal Extrusion
8	1	47.875" TSP46/S44 Vertical Extrusion	17a/17b	1/1	48" TSP46 Horizontal Extrusion
9	1	47.875" TSP46/S44 Vertical Extrusion	18	2	31.48" Z45 Horizontal Extrusion
			19	4	6" Z45 Horizontal Extrusion

Steps:

- 1) Attach vertical extrusions [2,4,6,8,10,12] to base plates [1,1a] with screws.
- 2) Connect upper verticals [3,5,7,9,11,13] to lower verticals [2,4,6,8,10,12] as shown.
- 3) Connect horizontal verticals [14a,14b], [15a,15b], [16a,16b], [17a,17b] as shown.
- 4) Connect vertical assemblies with horizontal as shown.
- 5) Attach SEG graphics to assembled backwall.

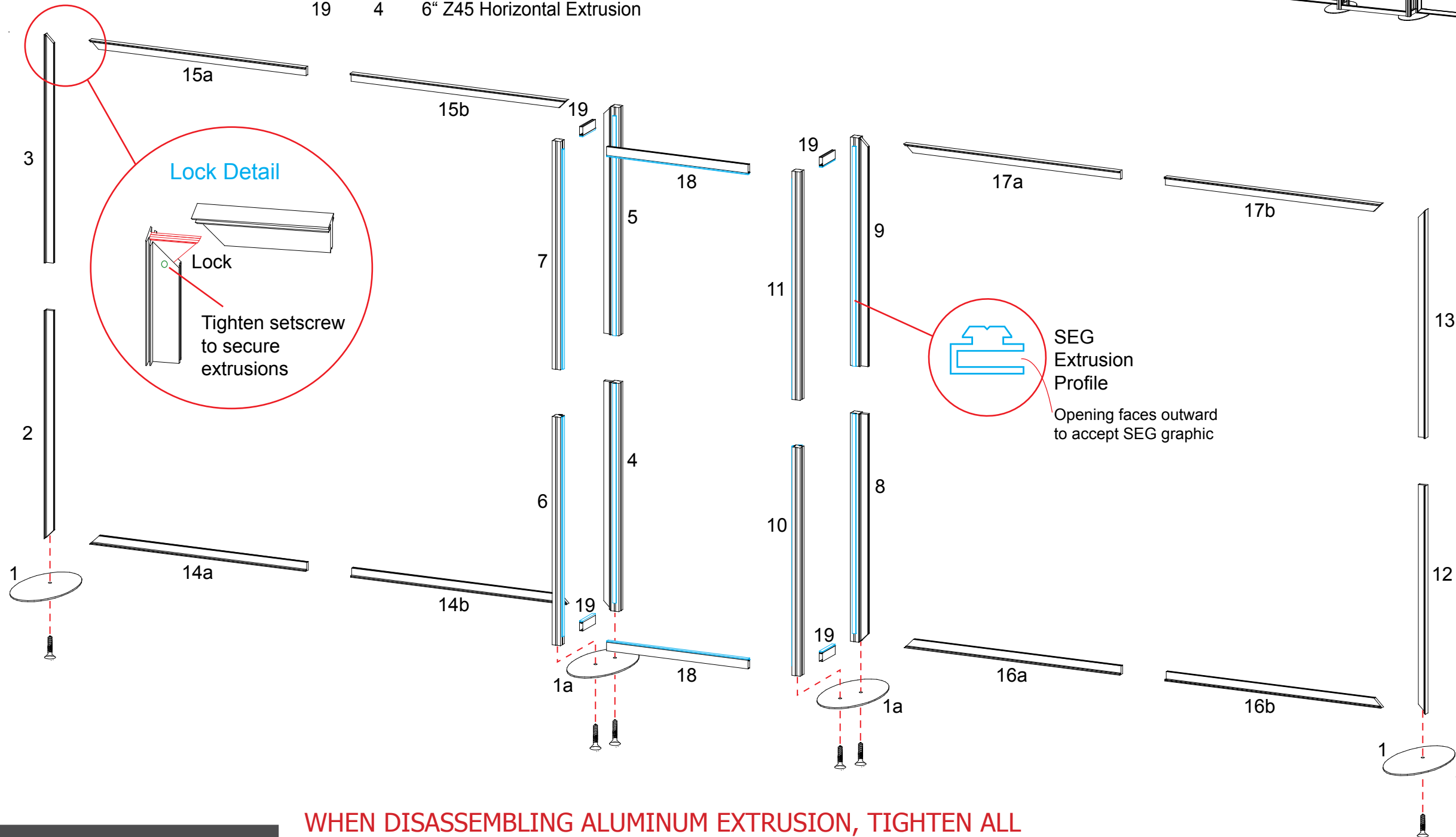
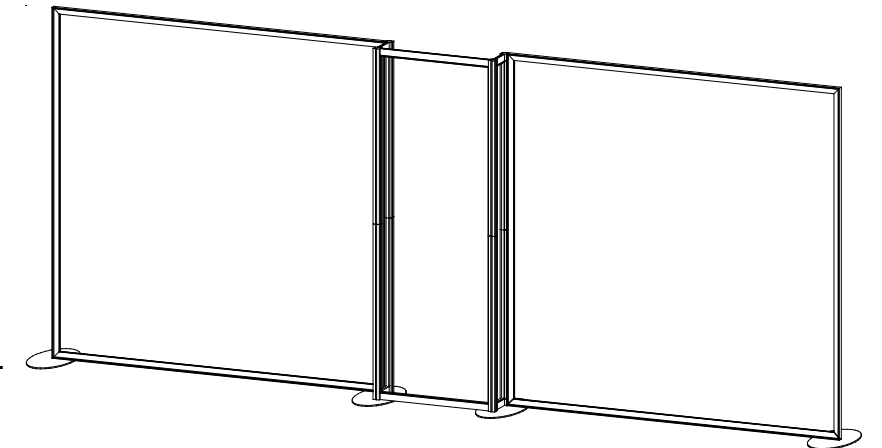

**WHEN DISASSEMBLING ALUMINUM EXTRUSION, TIGHTEN ALL SETSCREWS AND LOCKS TO PREVENT LOSS DURING SHIPPING**

866.652.2100

Item	Description
20	7.5" Horizontal Extrusion w/ Hook
21	12" 90° Vertical Extrusion
22	36" Horizontal Extrusion w/ Hook
23	12" 90° Vertical Extrusion
24	7.5" Horizontal Extrusion w/ Hook
25	7.5" Horizontal Extrusion
26	36" Horizontal Extrusion
27	7.5" Horizontal Extrusion
28	8.4" Vertical Extrusion
29	8.4" Vertical Extrusion

- Steps:
- 1) Connect parts together as shown.
  - 2) Apply pillowcase graphic.
  - 3) Hang assembled header from assembled backwall as shown.

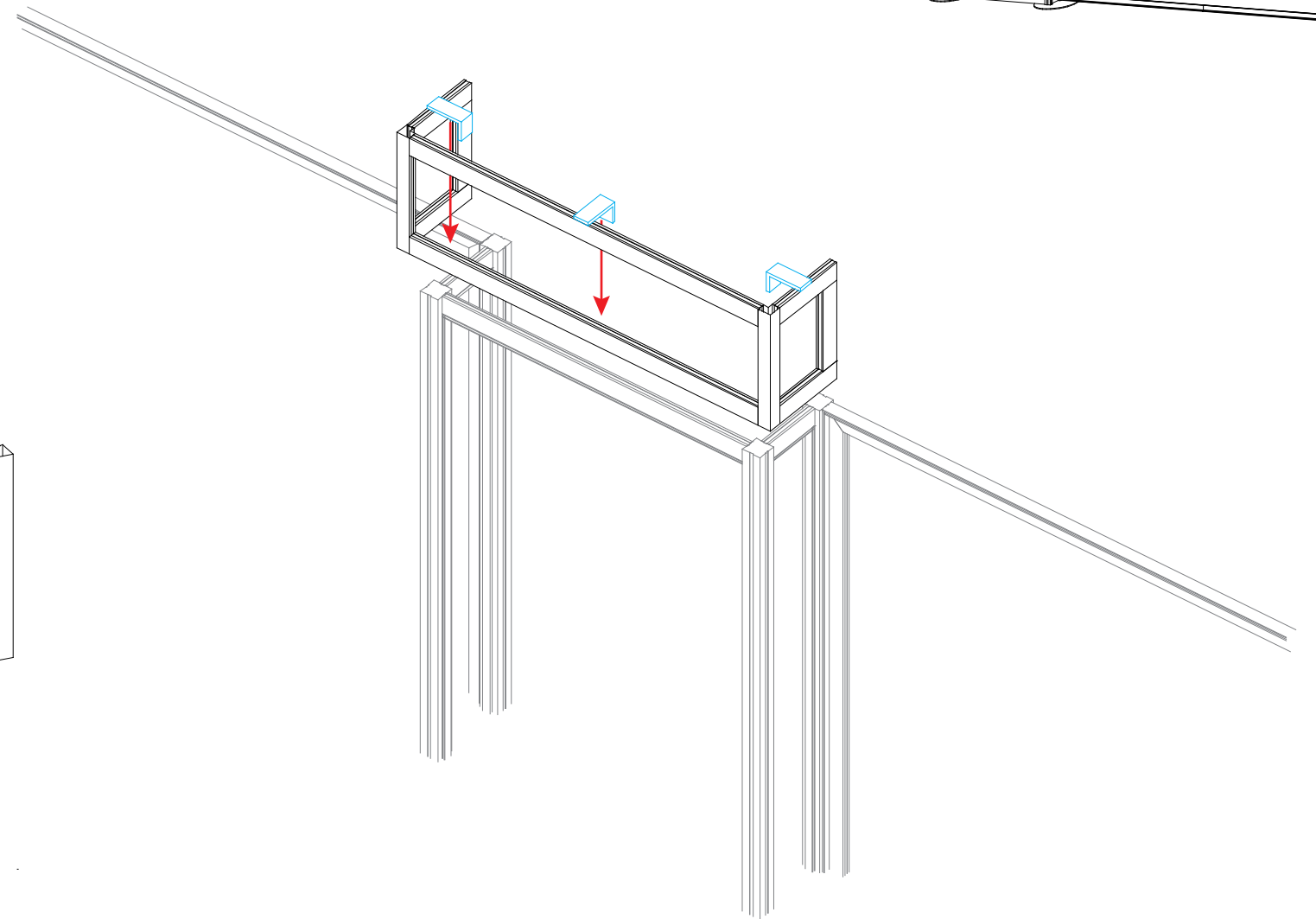
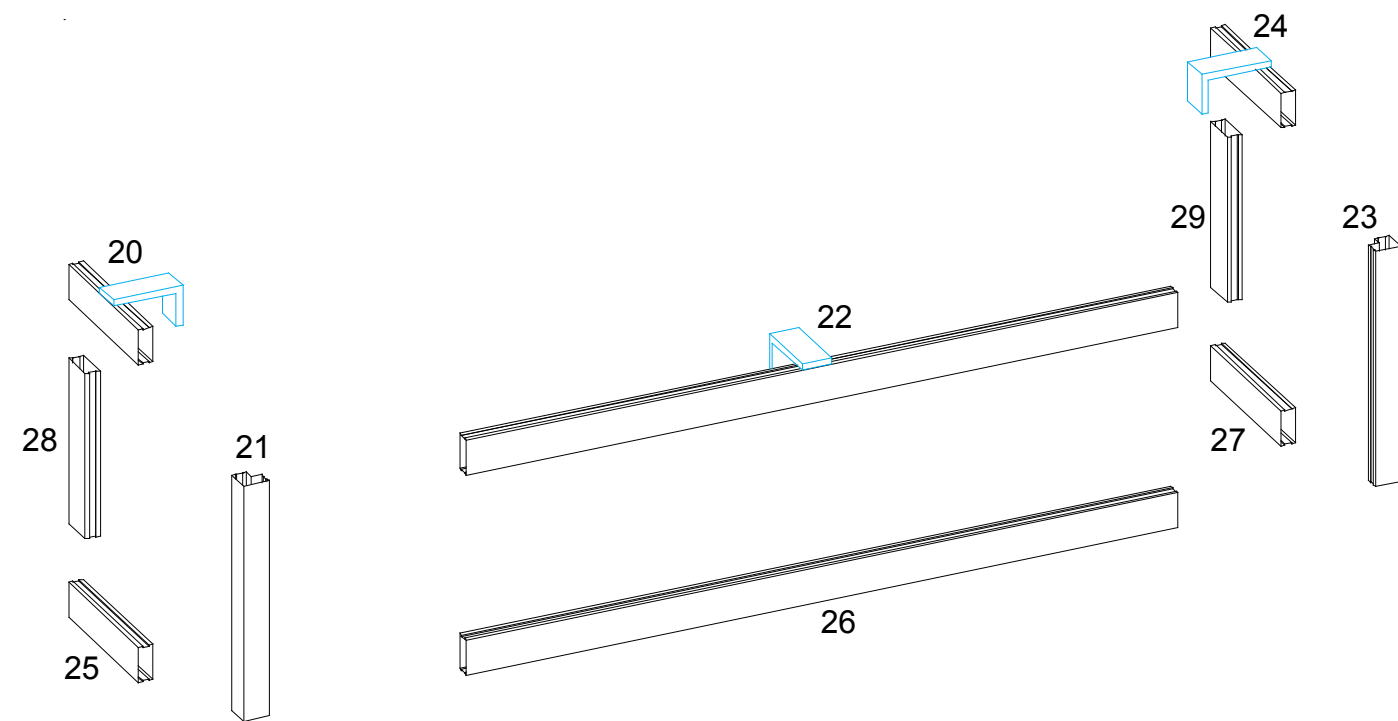
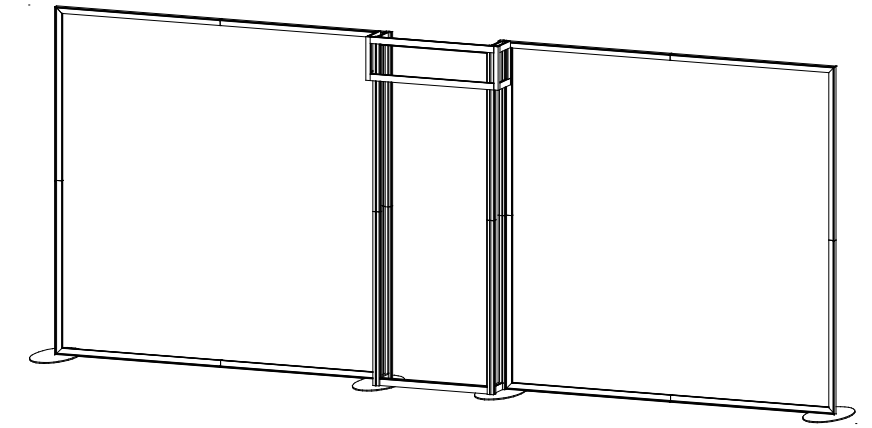

**WHEN DISASSEMBLING ALUMINUM EXTRUSION, TIGHTEN ALL SETSCREWS AND LOCKS TO PREVENT LOSS DURING SHIPPING**

866.652.2100

Steps:

- 1) Attach monitor mount to extrusion [30] with screws.
- 2) Attach monitor mount extrusion [30] to connectors in backwall with screws.
- 3) Attach lights to backwall as indicated.
- 4) Attach literature racks to backwall.

Item	Description
30	Monitor Mount Extrusion

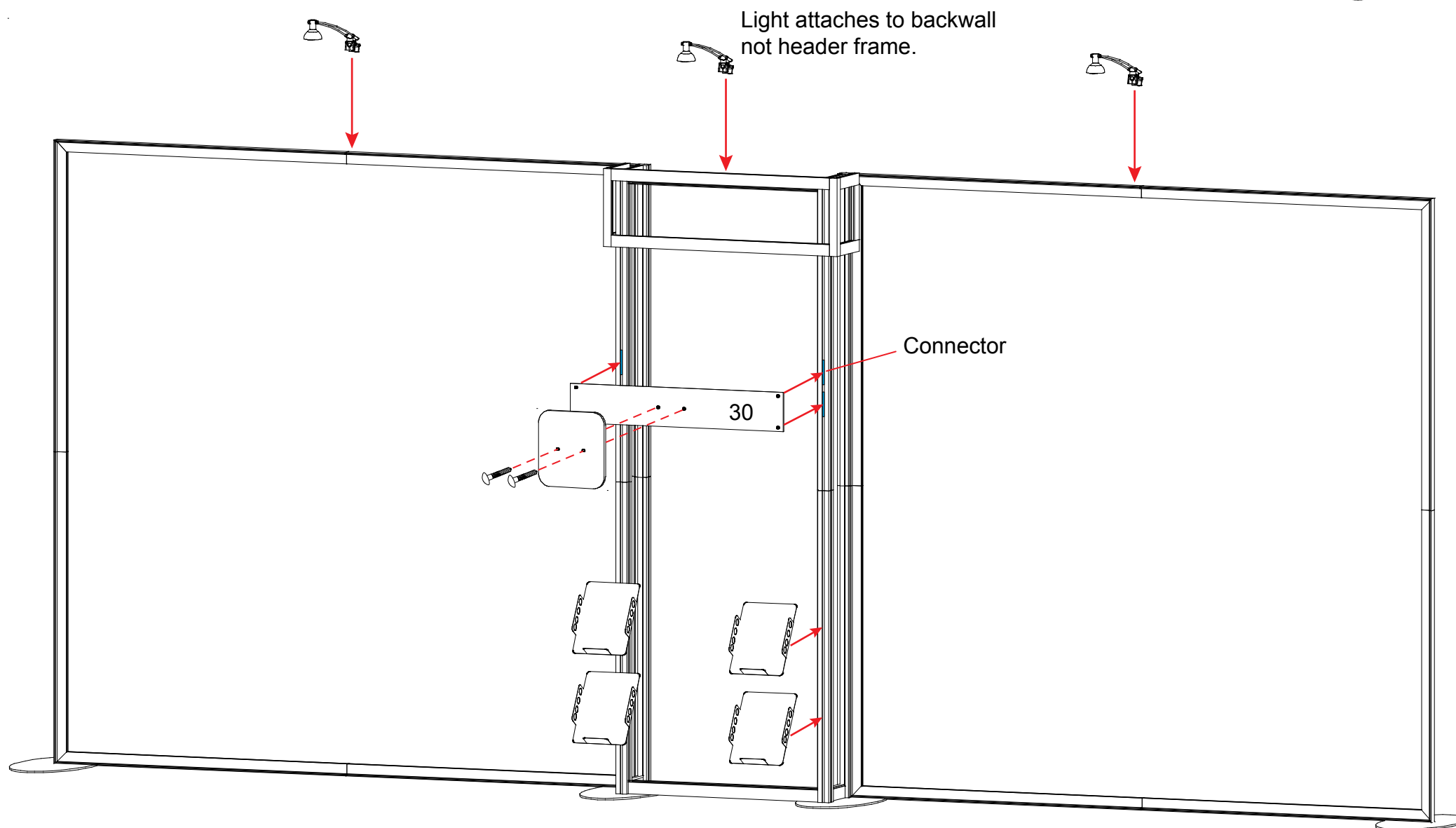
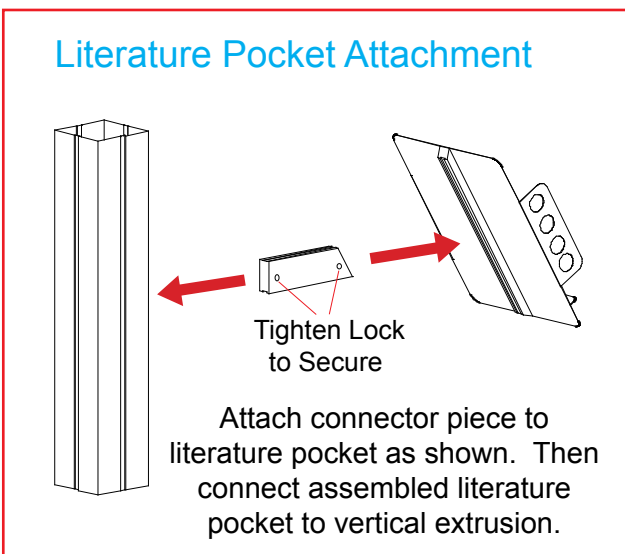
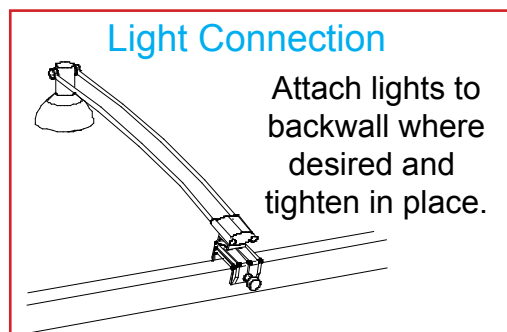
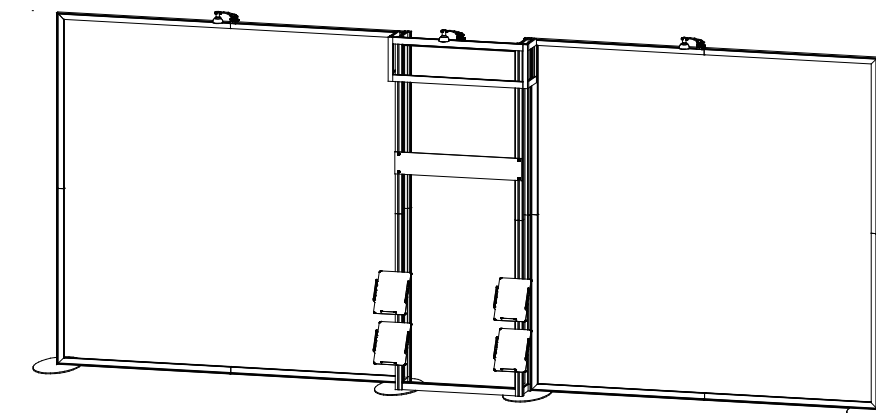

**WHEN DISASSEMBLING ALUMINUM EXTRUSION, TIGHTEN ALL SETSCREWS AND LOCKS TO PREVENT LOSS DURING SHIPPING**

Top View

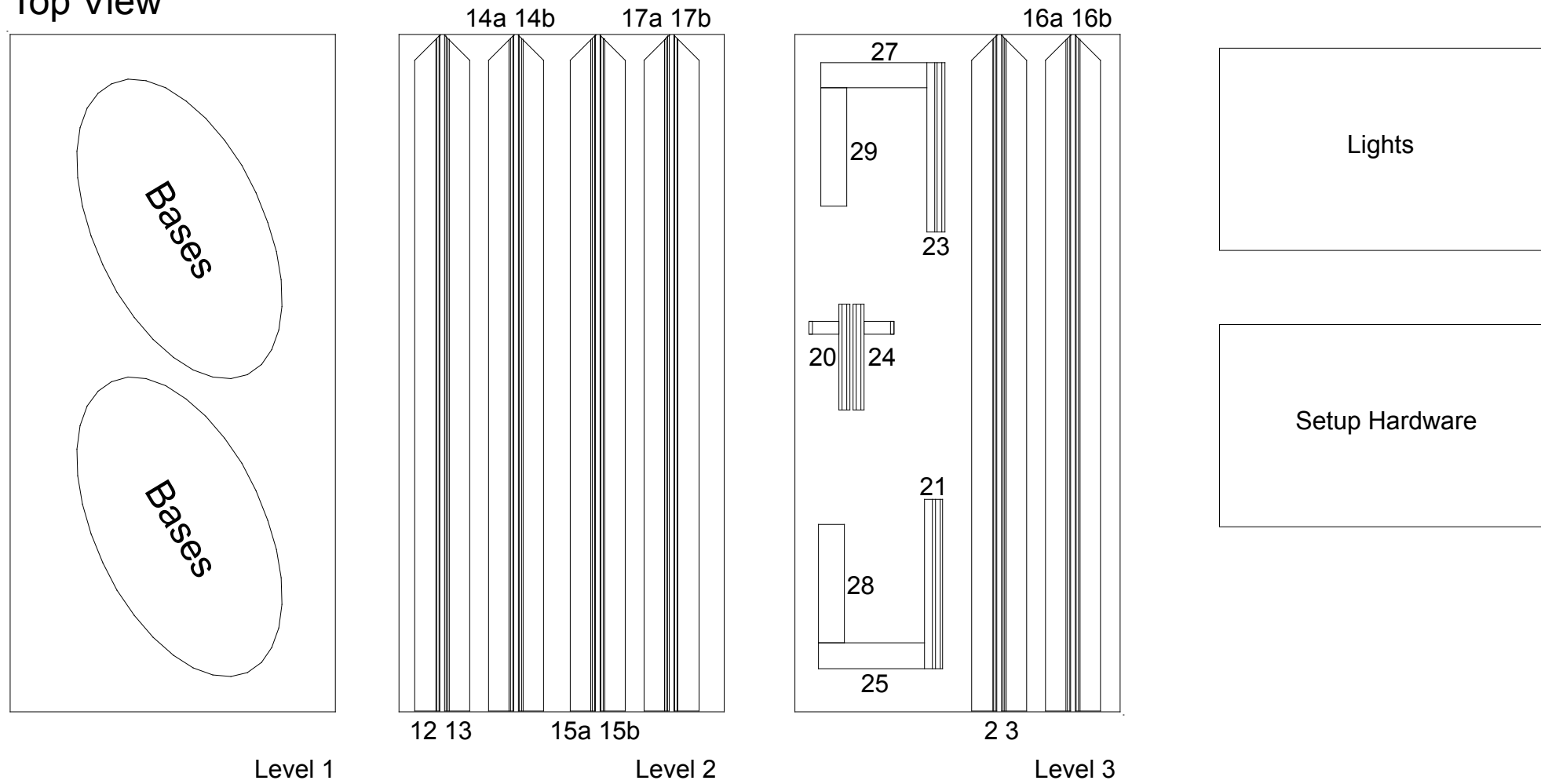

WHEN DISASSEMBLING ALUMINUM EXTRUSION, TIGHTEN ALL SETSCREWS AND LOCKS TO PREVENT LOSS DURING SHIPPING

Top View

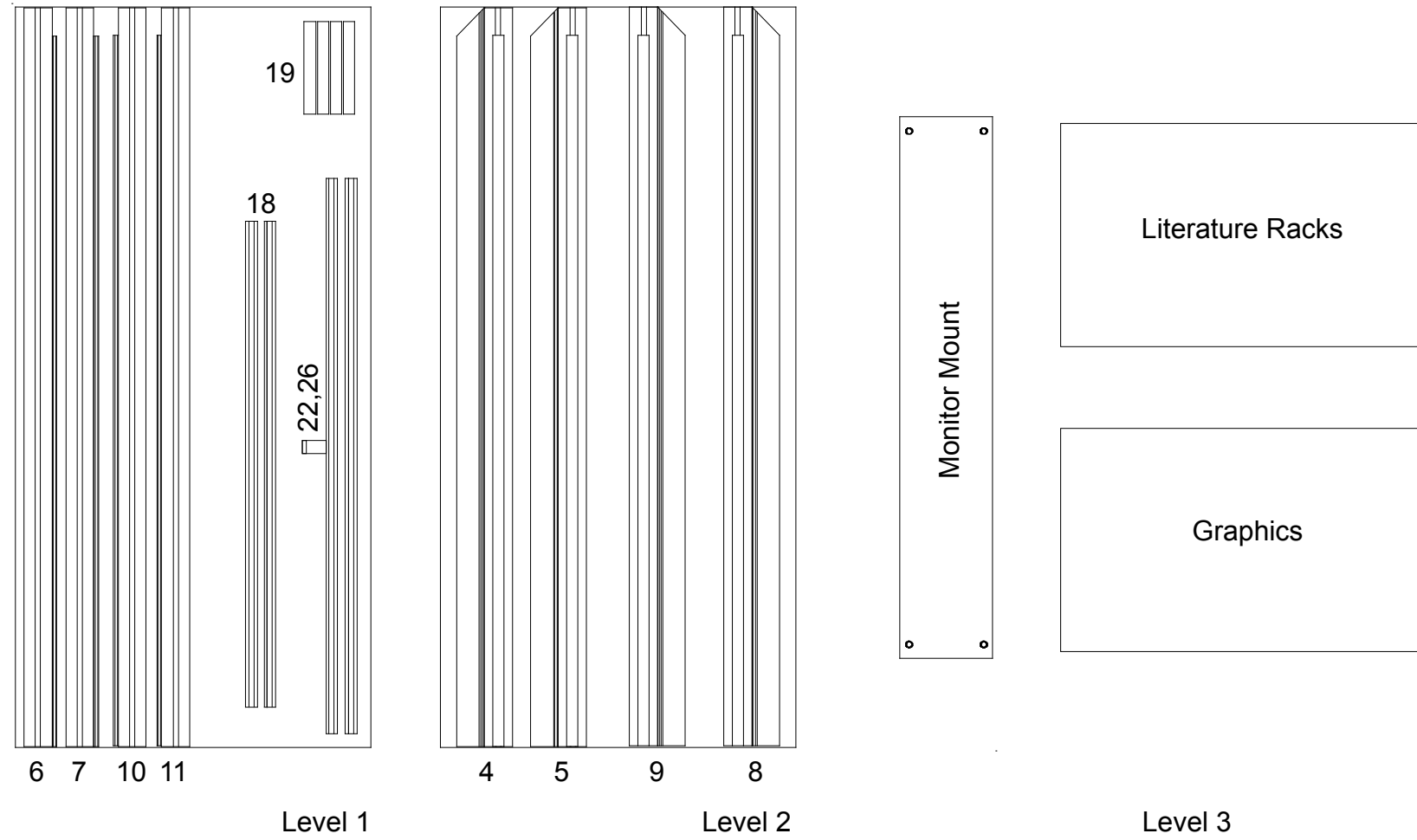

WHEN DISASSEMBLING ALUMINUM EXTRUSION, TIGHTEN ALL SETSCREWS AND LOCKS TO PREVENT LOSS DURING SHIPPING