

**visionary**<sup>™</sup>  
DESIGNS

WHEN DISASSEMBLING ALUMINUM EXTRUSION, TIGHTEN ALL SETSCREWS AND LOCKS TO PREVENT LOSS DURING SHIPPING

# visionary™ IDESIGNS

## Using Your Setup Instructions

The Visionary Designs Setup Instructions are created specifically for your configuration. They are laid out sequentially, including an exploded view of the entire display, and then a logical series of detailed steps to assemble the main structure and components. We encourage you to study the instructions **before** attempting to assemble your exhibit.

Each page reminds you to tighten the setscrews after disassembling your exhibit to prevent loss of the locks and setscrews (see below in RED). This is **VERY IMPORTANT**.

## Cleaning and Packing Your Display

- 1) Use care when cleaning aluminum extrusion or acrylic inserts. Use only non-abrasive cleaners.
- 2) When cleaning laminate inserts or countertops, use mild cleansers and a soft material such as cotton.
- 3) Keep all display components away from extreme heat and long exposure to sunlight to avoid warping and fading.
- 4) Retain all packing material. It will make re-packing much easier and will reduce the likelihood of shipping damage.



**The Tool**

Most Visionary Designs exhibits can be assembled with the supplied Hex Key Tool. Occasionally, a flat head screwdriver may be required.



Detail A

**Typical Connection**



**Typical Connection (cont'd)**

Most horizontal extrusion connections have a patented expandable lock. This lock inserts into the groove of an opposing extrusion. Tightening the lock with the Hex Key Tool expands the lock and creates a strong positive connection.

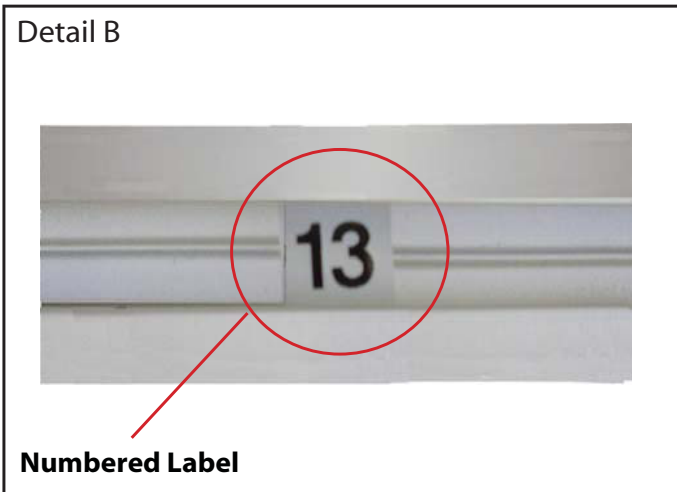

Detail B

**Numbered Label**

Each extrusion contains a numbered label which corresponds with setup instructions. The label is located within a groove of the extrusion (when possible). With Visionary Designs the labels contain Black numbers unless otherwise specified.



Detail C

**Horizontal Inline Connection** (remove only one setscrew)

Remove only (1) setscrew when disassembling. Replace setscrew in extrusion after assembling it. Before packing, replace setscrew in extrusion to avoid losing it.

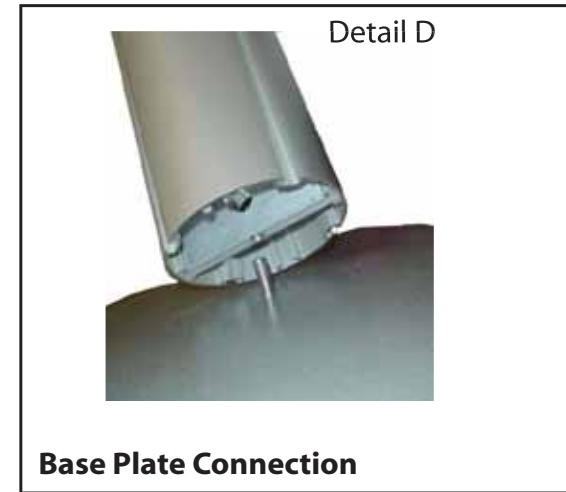

Detail D

**Base Plate Connection**

Attach base plate to round or square vertical extrusion using the bolt provided. Be careful not to strip the threads.

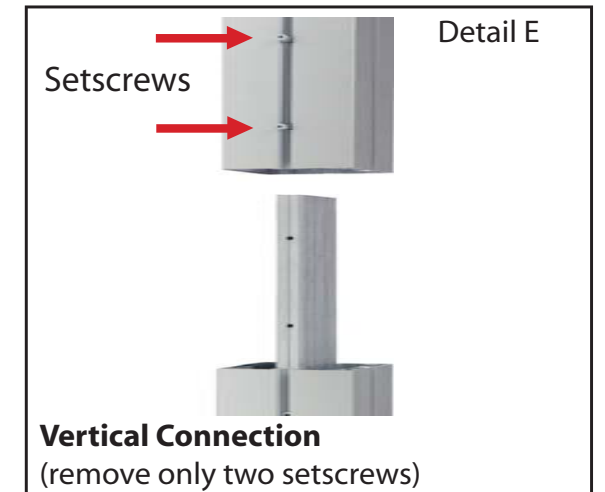

Detail E

**Vertical Connection**  
(remove only two setscrews)

When vertical extrusions are packed in portable cases rather than crates or tubs, they must be broken down into smaller sections which then require assembly.

Remove only (2) setscrews when disassembling. Replace setscrews in extrusion after assembling it. Before packing, replace setscrews in extrusion to avoid losing them.

**WHEN DISASSEMBLING ALUMINUM EXTRUSION, TIGHTEN ALL SETSCREWS AND LOCKS TO PREVENT LOSS DURING SHIPPING**

Item	Qty.	Description
1	1	Base Plate
2	1	44.75" h Half Round Vertical extrusion
3	1	44.75" h Half Round Vertical extrusion
4	1	Base Plate
5	1	44.75" h Half Round Vertical extrusion
6	1	44.75" h Half Round Vertical extrusion
7	2	48" h Horizontal extrusion
7a	2	48" h Horizontal extrusion

**Steps**

- 1) Connect vertical extrusions [2 to 3 and 5 to 6] together with connectors and screws provided.
- 2) Connect base plates [1 and 4] to vertical assemblies [2/3 and 5/6].
- 3) Connect lower horizontal extrusions [7 and 7a] between vertical assemblies [2/3 and 5/6] as shown.
- 4) Place lights staggered inside the vertical extrusions making sure to run cords down thru bottom opening.
- 5) Place Sintra Cap and header atop assembled lightbox.

**Example of A10 Clamp Attachment**

Attach A10 clamps to side groove of vertical extrusions for wing panel attachment

Slide connector on back of A10 clamp into groove of extrusion.

When desired location is found, tighten set screw to secure.

Tighten knob to secure shelf in place.

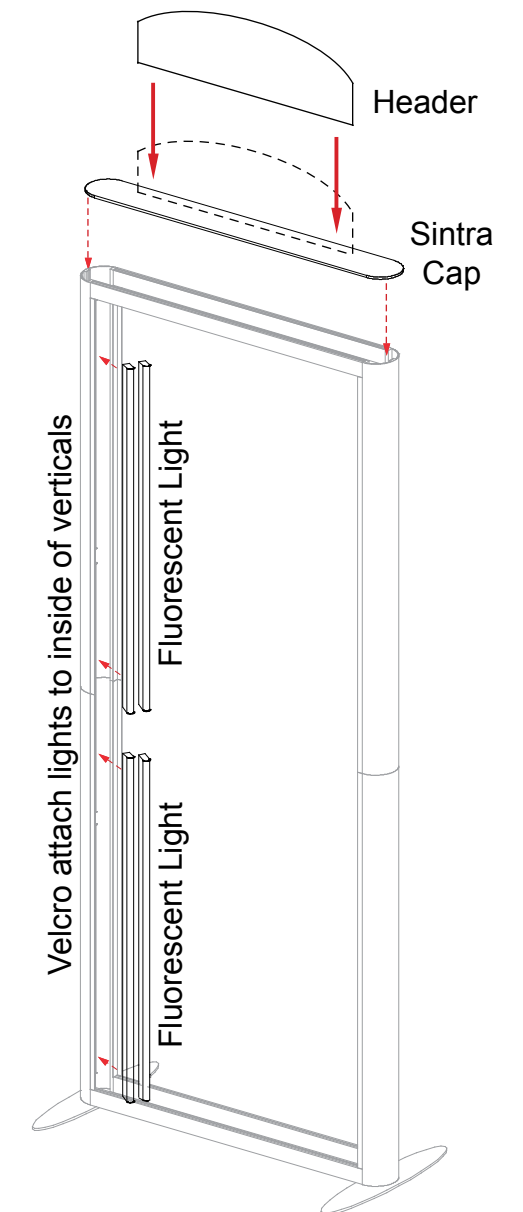
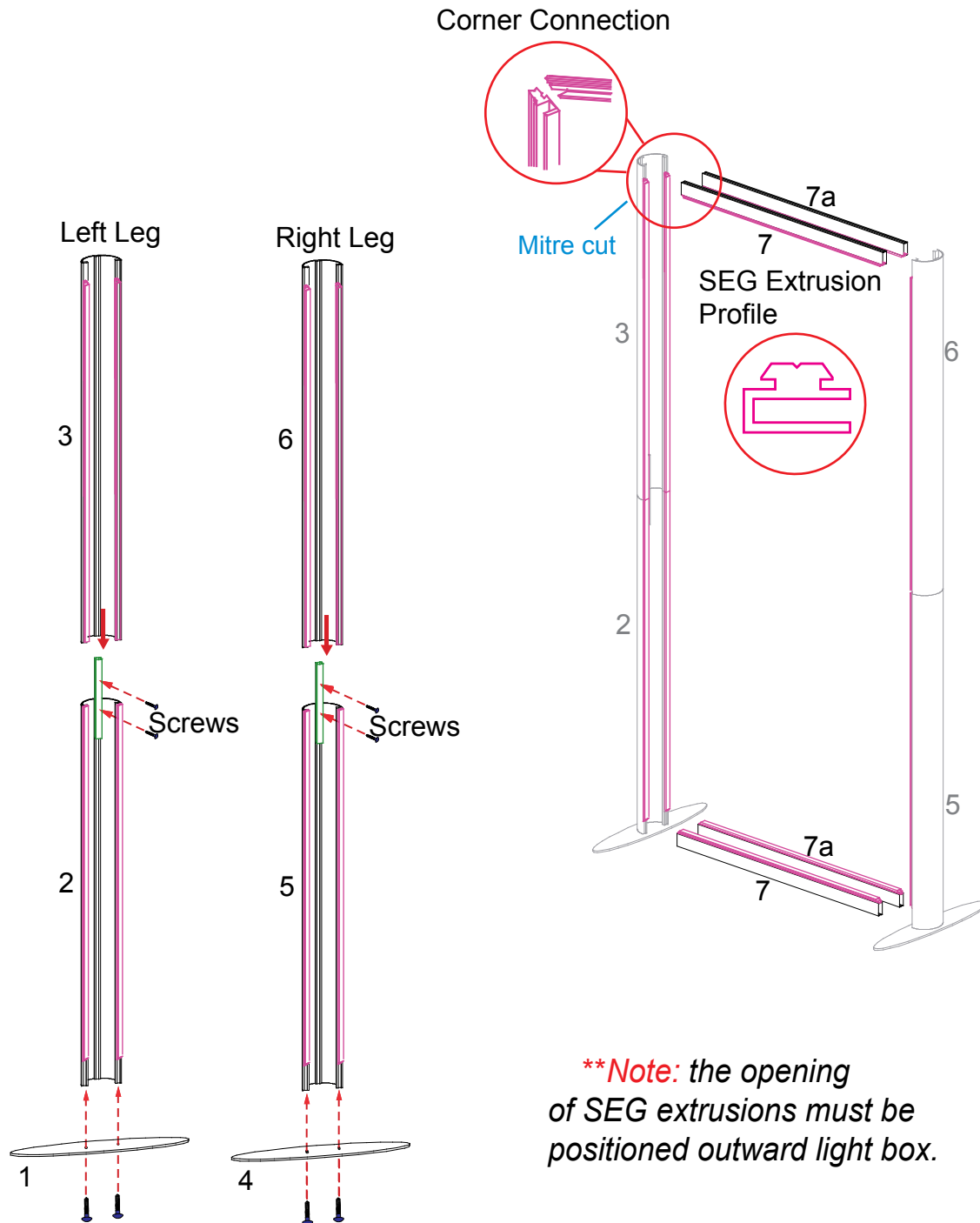

**WHEN DISASSEMBLING ALUMINUM EXTRUSION, TIGHTEN ALL SETSCREWS AND LOCKS TO PREVENT LOSS DURING SHIPPING**

866.652.2100

Item	Description
8	45" SEG Extrusion
9	45" SEG Extrusion
10	45" SEG Extrusion
11	45" SEG Extrusion
12	45" SEG Extrusion
13	45" SEG Extrusion
14	45" SEG Extrusion
15	45" SEG Extrusion

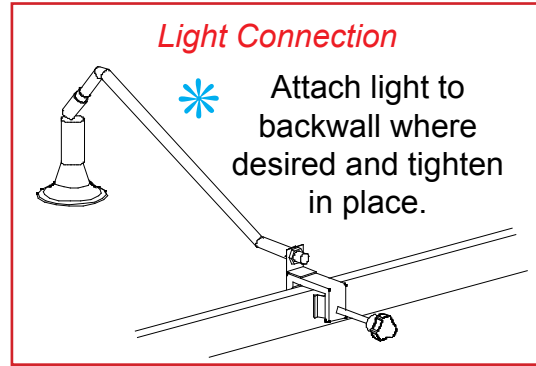

**Setups:**

- 1) Assembled SEG extrusions together on floor.
- 2) Apply SEG graphic to assembled frame.
- 3) Attach feet to both sides of assembled frame where indicated.
- 4) Attach wing panels to A10 clips as shown.

\*\*\*\* See attached SEG graphic installation for graphic attachment

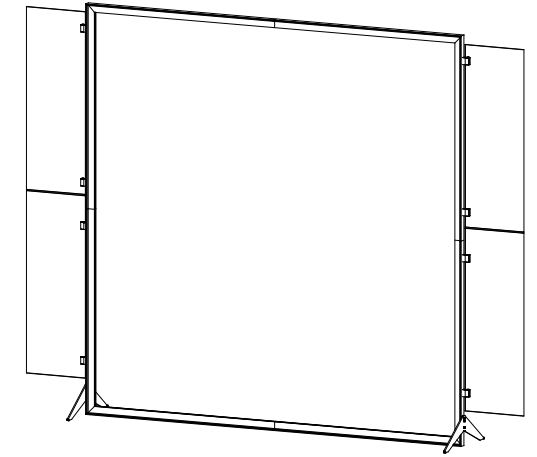

**A10 Clamp Attachment**

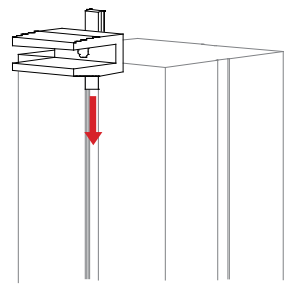

Slide connector on back of A10 clamp into groove of extrusion.

When desired location is found, tighten set screw to secure.

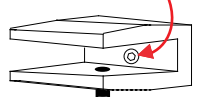

Tighten knob to secure shelf in place.

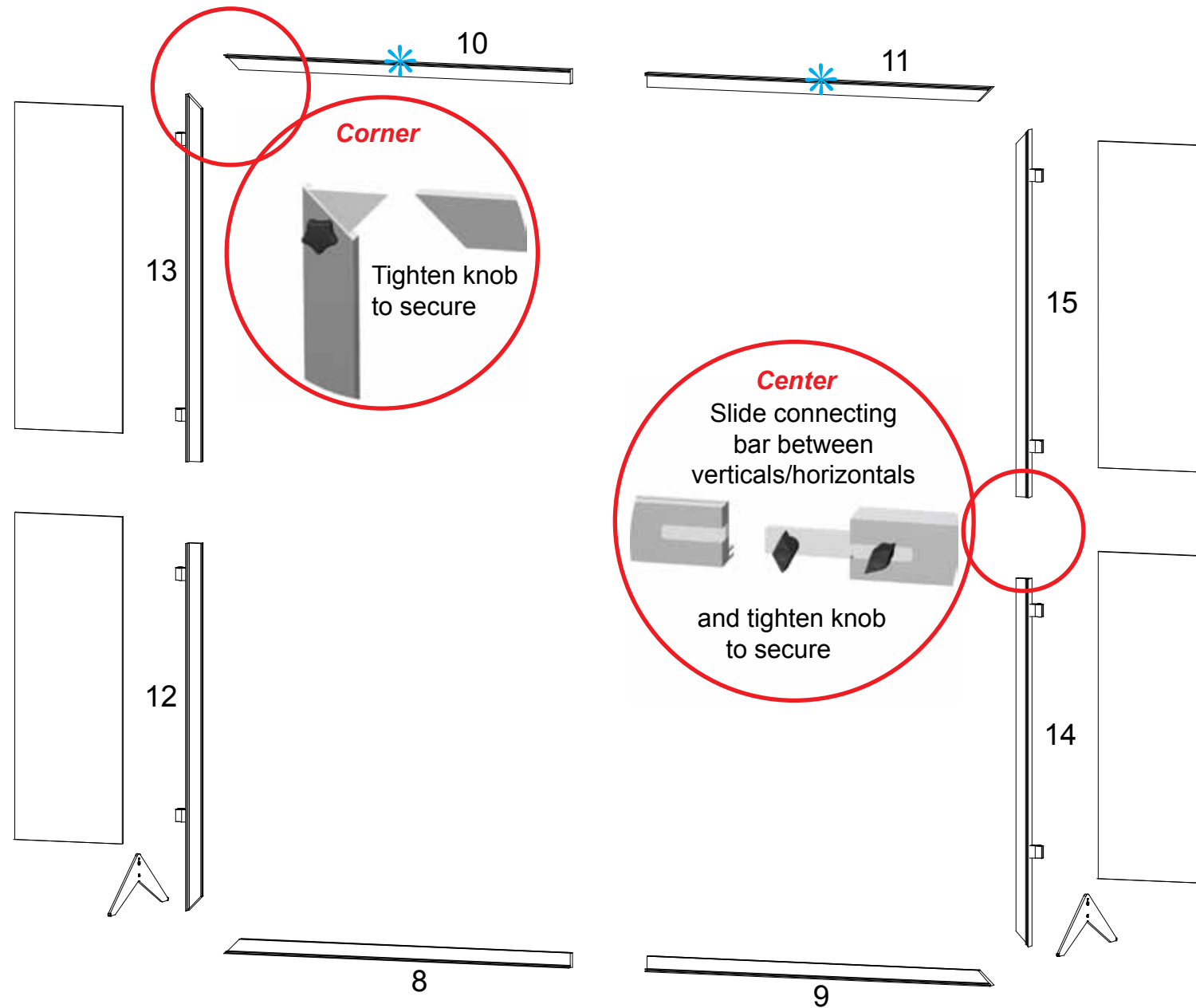

**Foot Attachment**

Hook keyhole cut out up bolt

Tighten Knob to secure



**WHEN DISASSEMBLING ALUMINUM EXTRUSION, TIGHTEN ALL SETSCREWS AND LOCKS TO PREVENT LOSS DURING SHIPPING**

866.652.2100

Item	Qty.	Description
1	1	18"D Round Base Plate
2	1	40"h Lower Round Vertical Extrusion
3	1	40"h Upper Round Vertical Extrusion
4	1	36"h Round Vertical Extrusion

**Steps**

- 1) Attach vertical extrusions [2 and 4] to base plate [1] as shown.
- 2) Attach upper vertical extrusion [3] atop vertical extrusion [2].
- 3) Attach tapered plex wing to front of vertical extrusion [4] using standoff caps and 16"D round sintra sign to vertical extrusion [3].
- 3) Place and attach counter atop vertical extrusion [4].

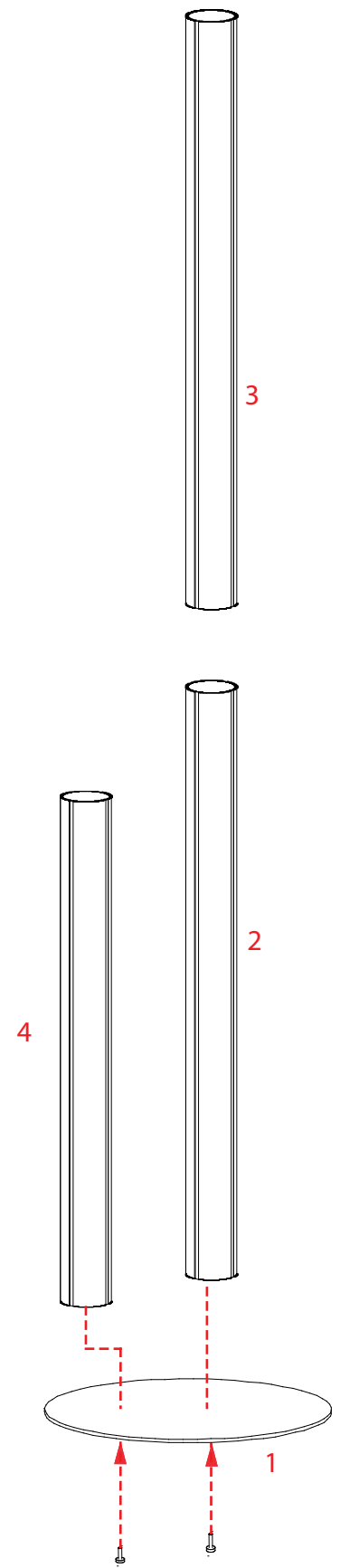

**Sign Attachment**

Slide stand off barrels into groove of vertical extrusion

Secure Sign to stand off barrels using stand off caps

**Monitor Mount Attachment**

Slide mounting connector pieces into groove of extrusion. Tighten setscrew to secure in place.

Attach back plate to connectors on vertical extrusion using screws. Then attach top plate and tighten setscrews to secure.

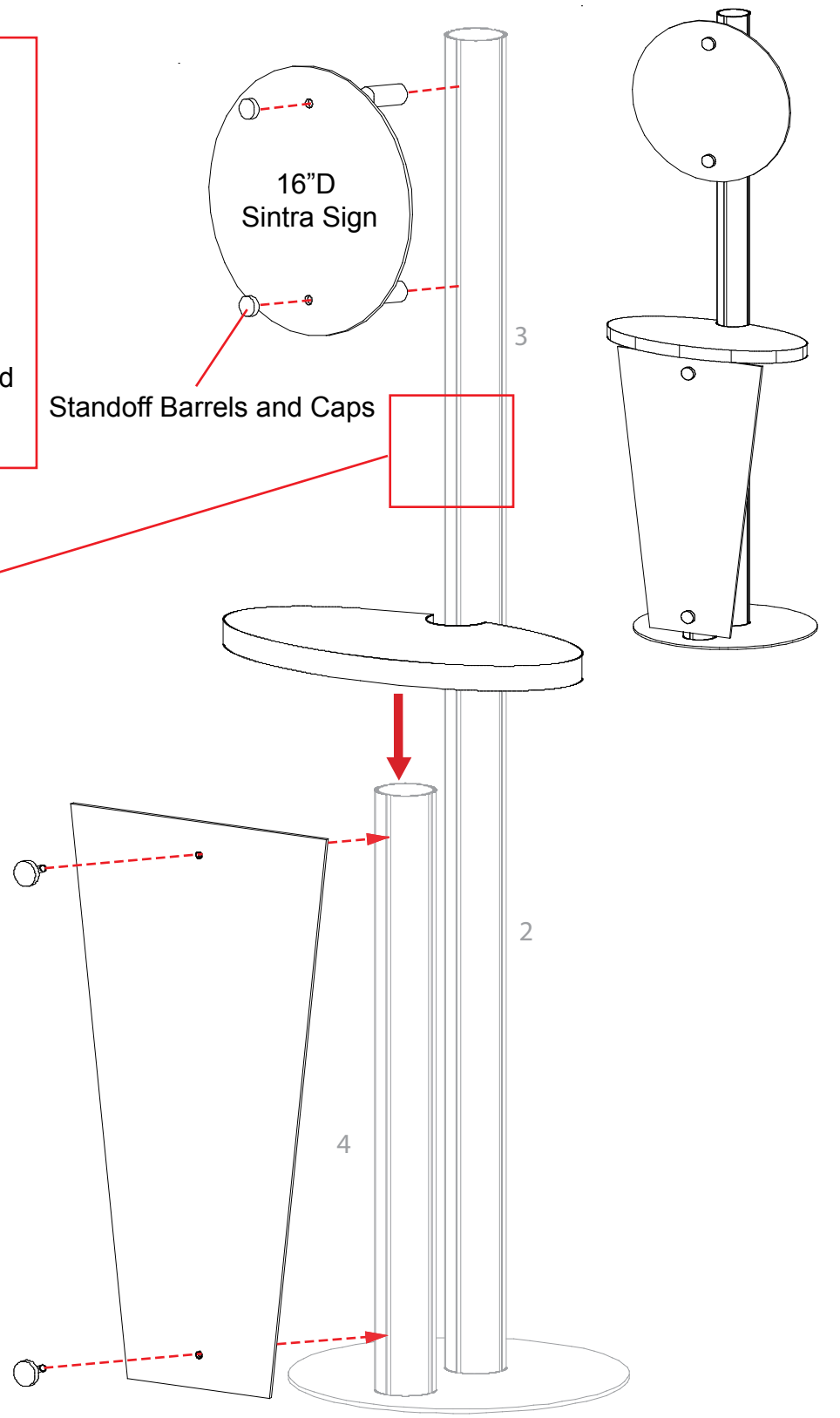

**WHEN DISASSEMBLING ALUMINUM EXTRUSION, TIGHTEN ALL SETSCREWS AND LOCKS TO PREVENT LOSS DURING SHIPPING**

866.652.2100

Item	Quantity	Description
1	1	38" h Vertical Extrusion
2	1	38" h Vertical Extrusion
3	1	38" h Vertical Extrusion
4	1	38" h Vertical Extrusion
5	2	21.2810" w Horizontal Extrusion
6	2	10.75" w Horizontal Extrusion
7	2	21.2810" w Horizontal Extrusion
8	2	10.75" w Horizontal Extrusion

**Steps:**

- 1) Connect horizontal extrusions [5 and 6] between vertical extrusions [1, 2, 3 and 4] resting atop stoppers at approximately 4" up from floor to bottom of metal.
- 2) Set floor in place atop lip of horizontal extrusions.
- 3) Place doors and inserts in place as shown.
- 4) Connect horizontal extrusions [7, and 8] between vertical extrusions [1, 2, 3 and 4] and atop inserts and door.
- 5) Velcro shelf supports to inside of pedestal, then set internal shelf atop supports.
- 6) Place counter top on assembled pedestal.

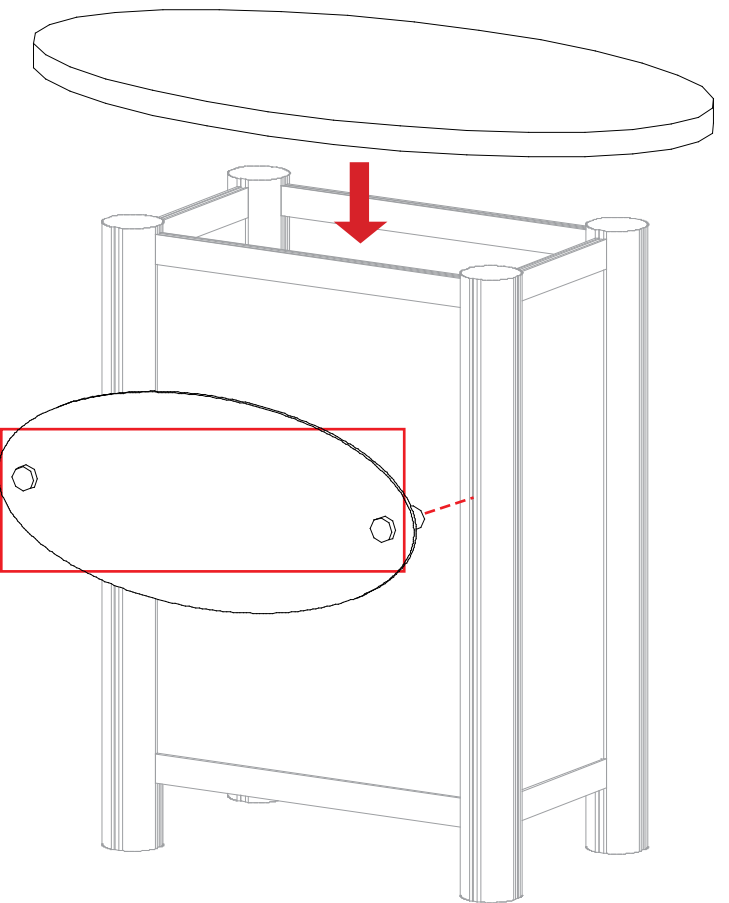
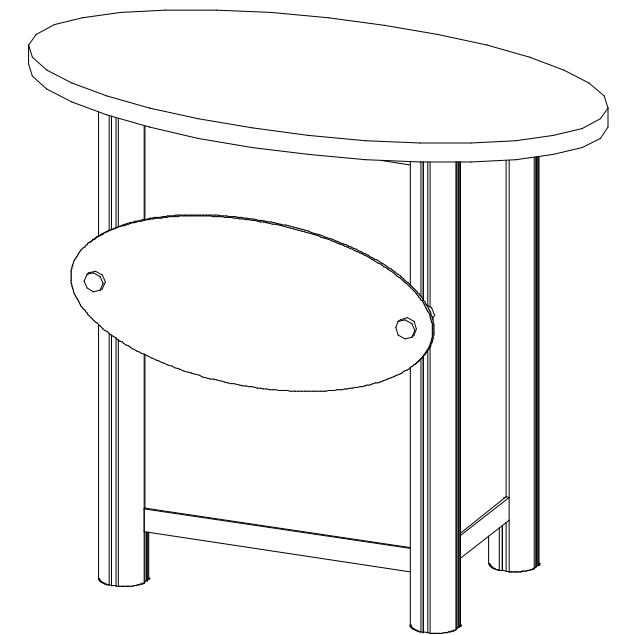
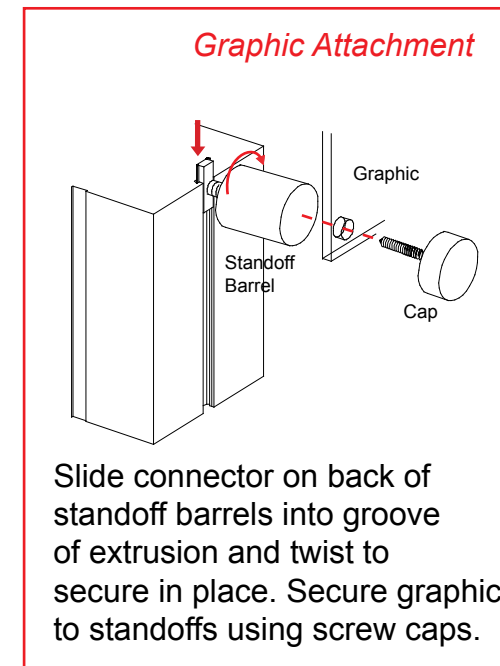
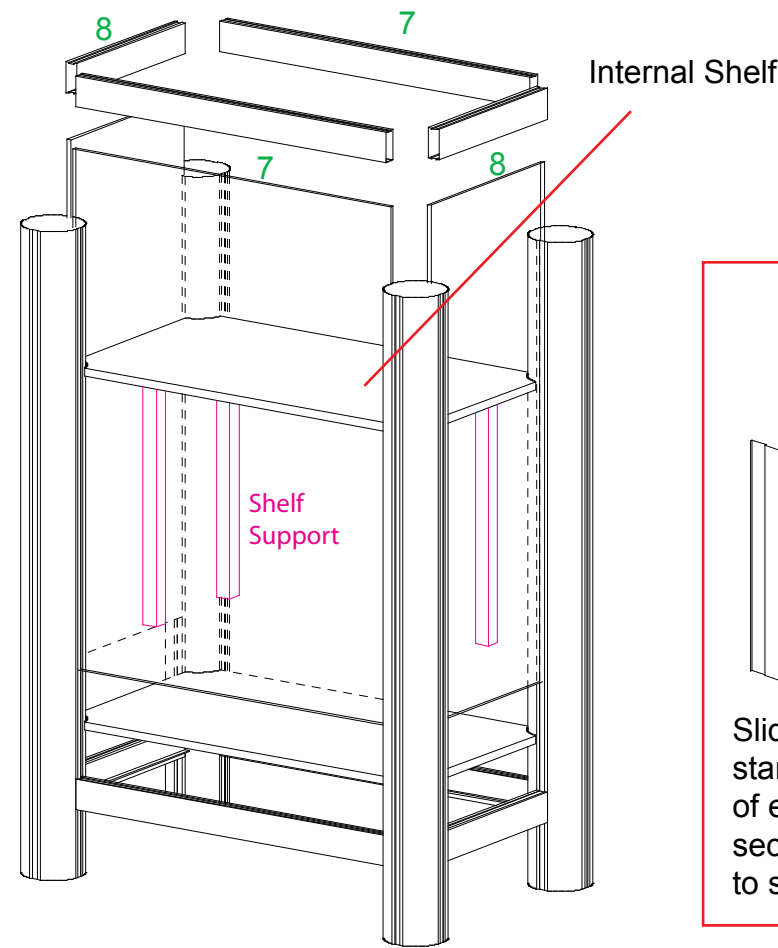
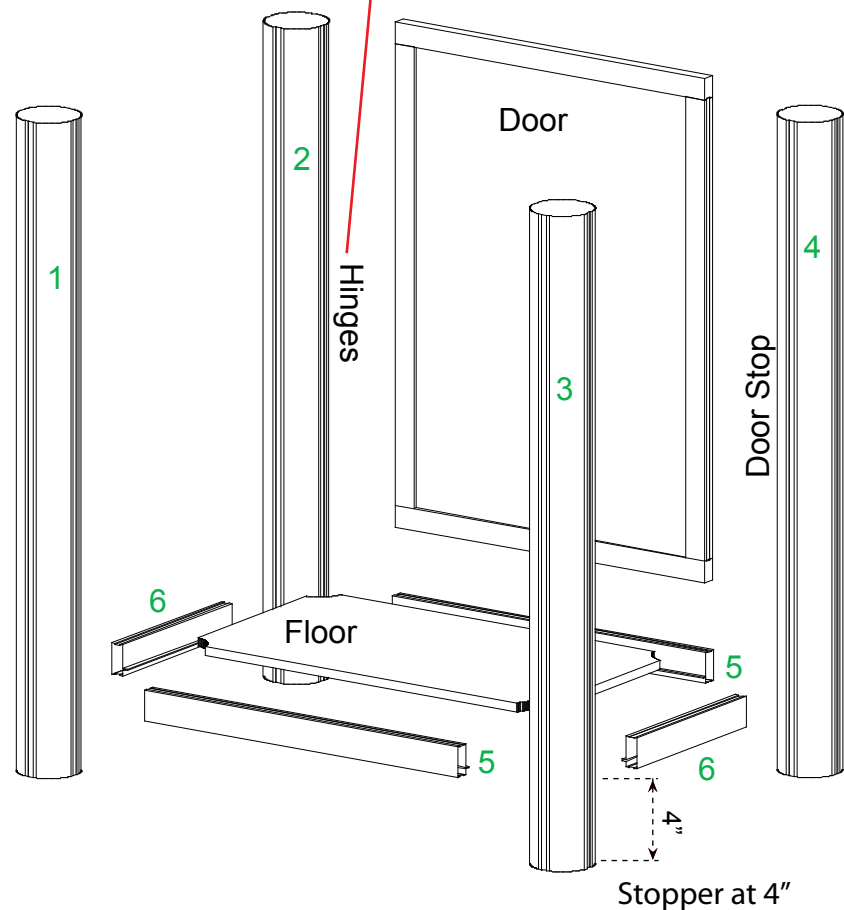
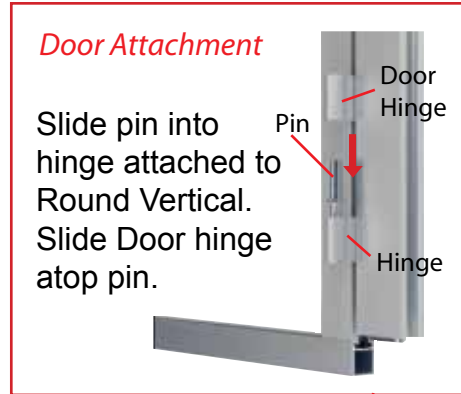

**WHEN DISASSEMBLING ALUMINUM EXTRUSION, TIGHTEN ALL SETSCREWS AND LOCKS TO PREVENT LOSS DURING SHIPPING**

Top View of each Level

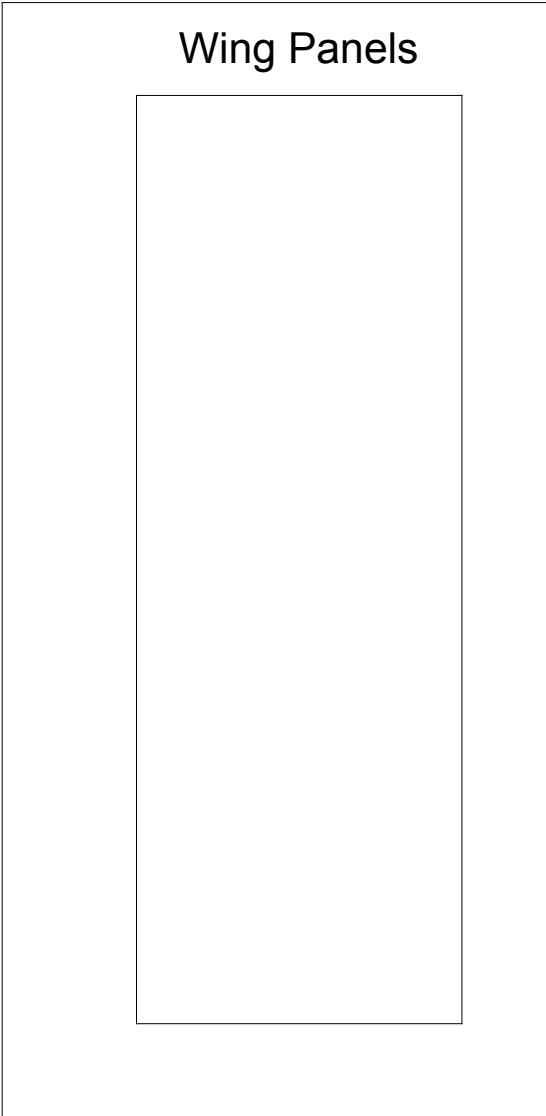

Level 1

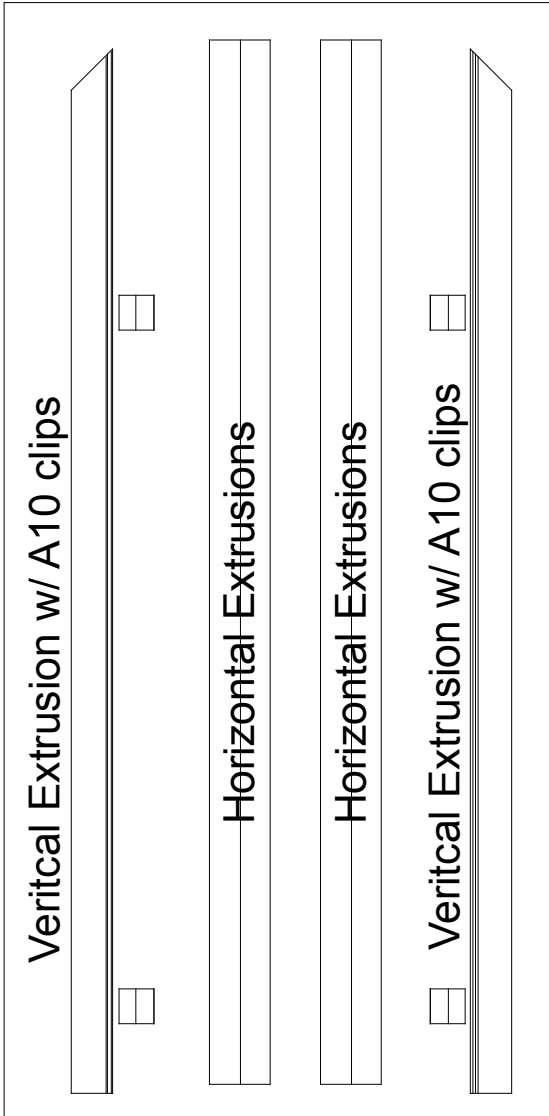

Level 2

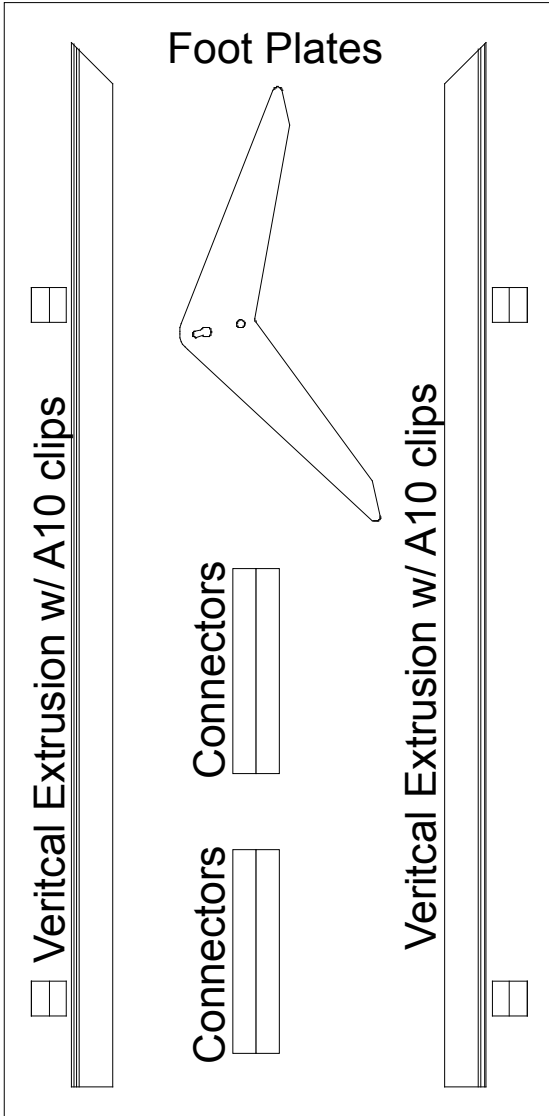

Level 3

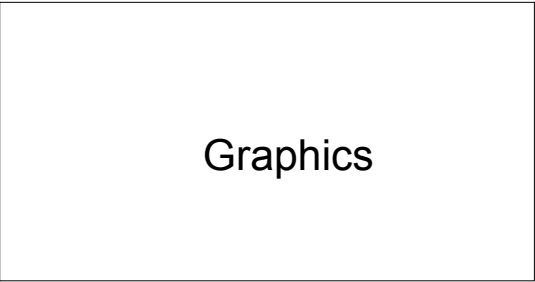
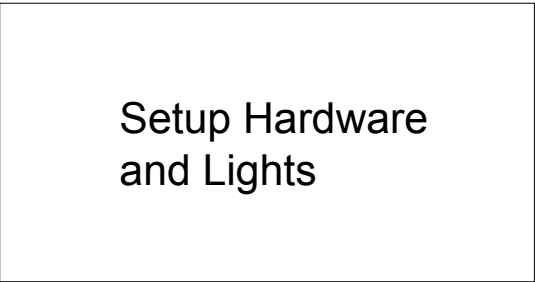

WHEN DISASSEMBLING ALUMINUM EXTRUSION, TIGHTEN ALL SETSCREWS AND LOCKS TO PREVENT LOSS DURING SHIPPING

Top View of each Level

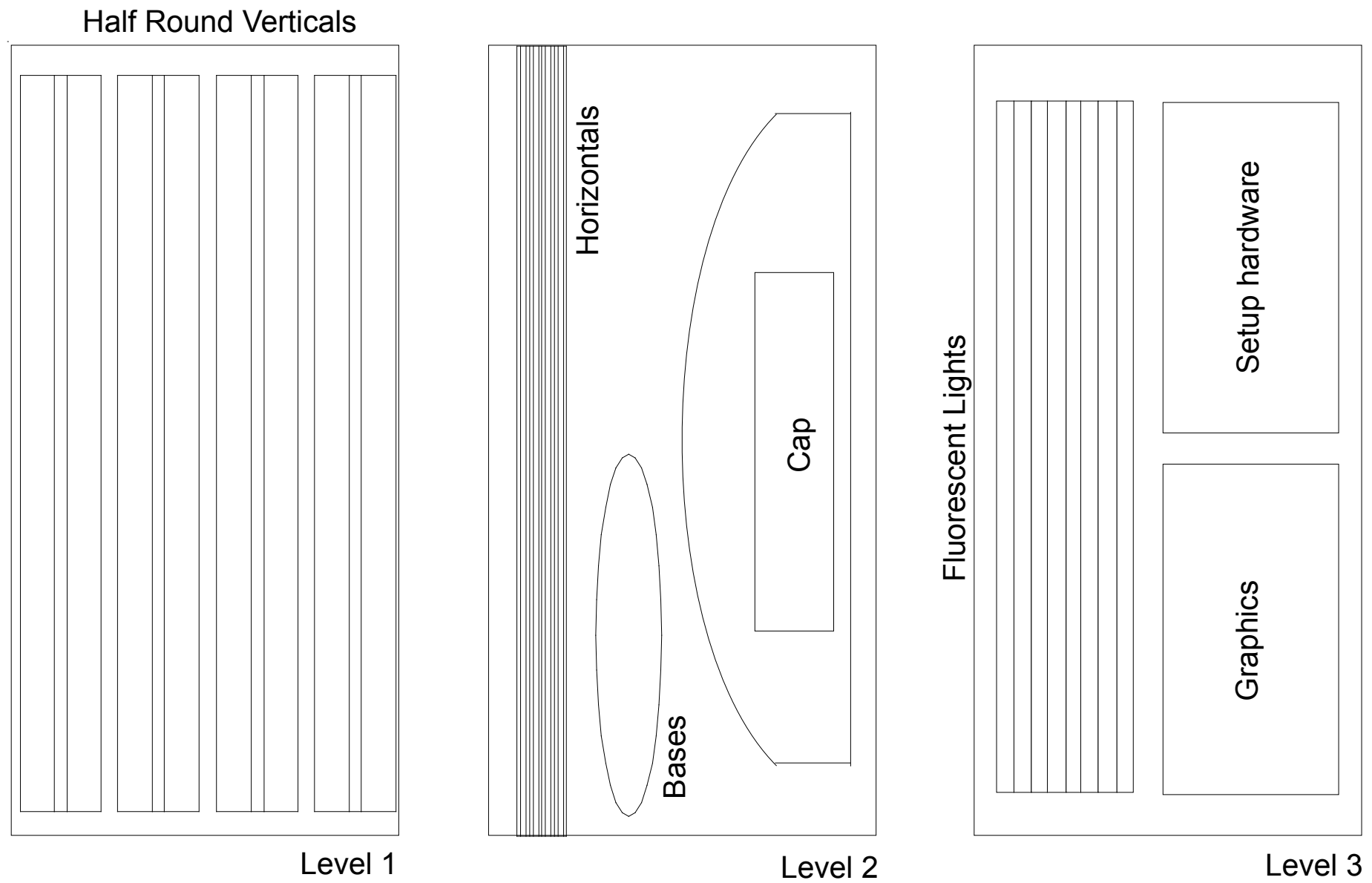

WHEN DISASSEMBLING ALUMINUM EXTRUSION, TIGHTEN ALL SETSCREWS AND LOCKS TO PREVENT LOSS DURING SHIPPING

Top View of each Level

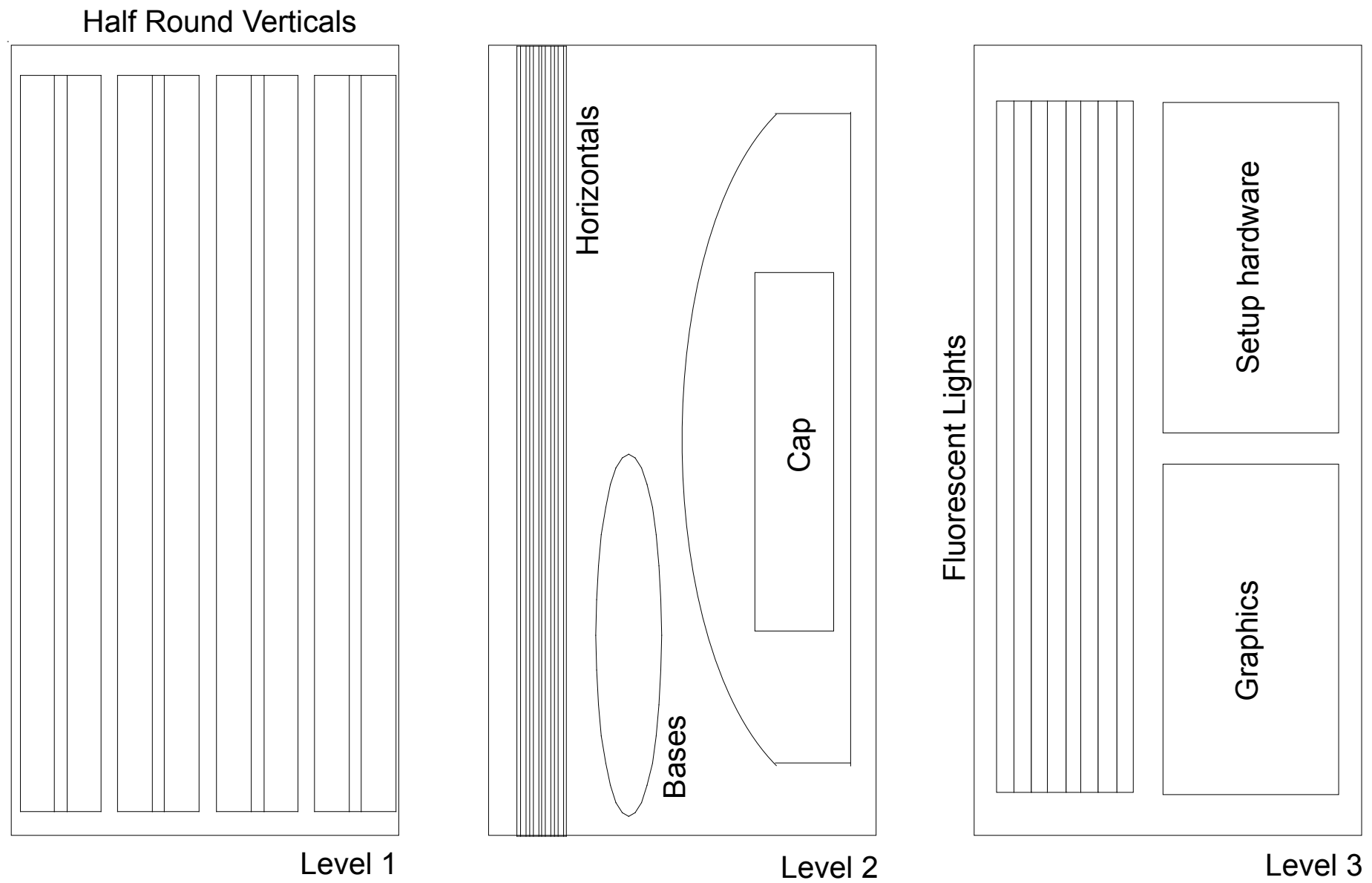

WHEN DISASSEMBLING ALUMINUM EXTRUSION, TIGHTEN ALL SETSCREWS AND LOCKS TO PREVENT LOSS DURING SHIPPING

Top View of Each Level

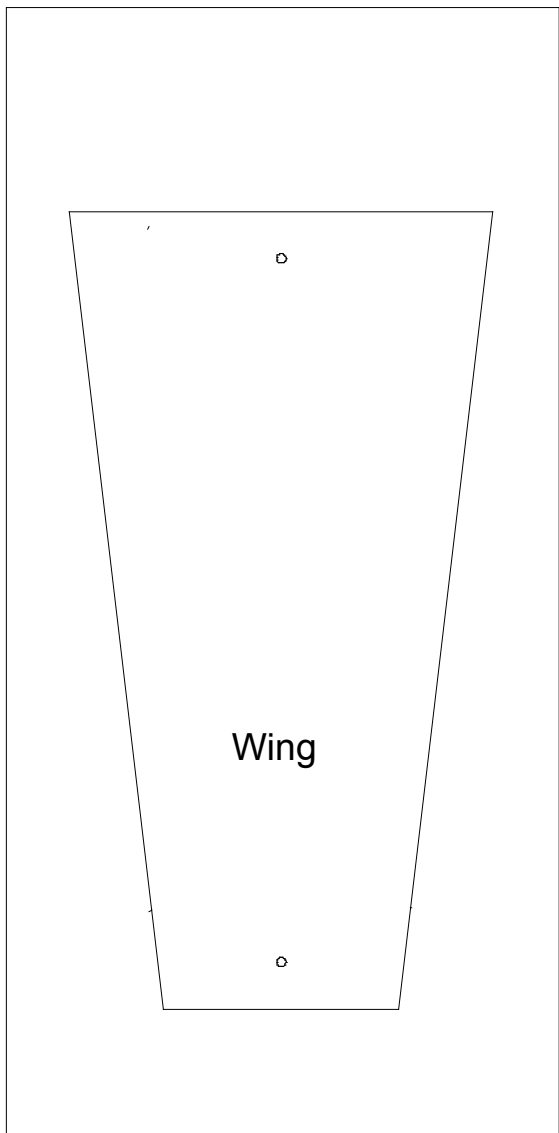

Level 1

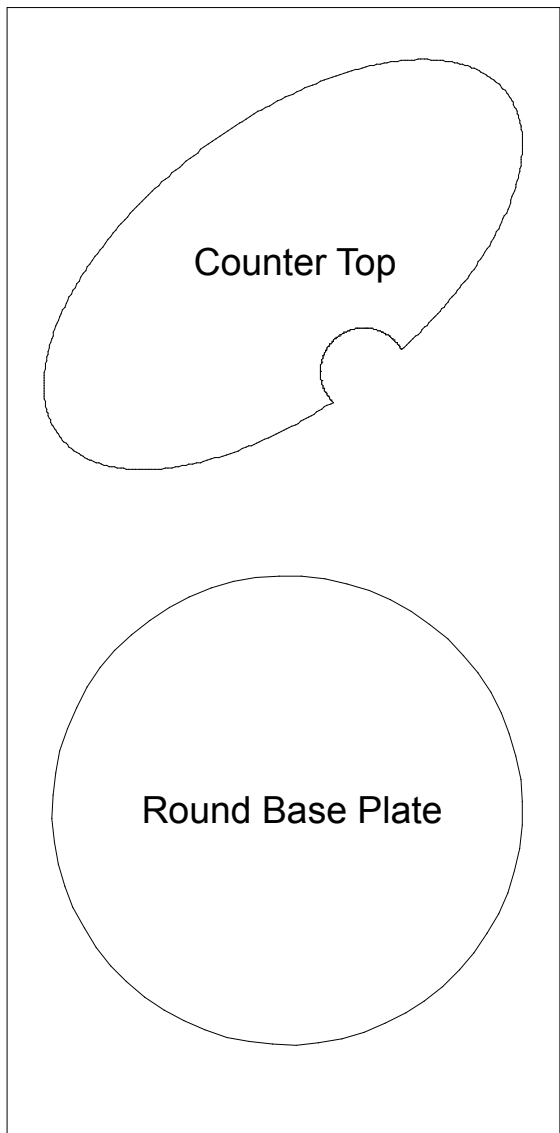

Level 2

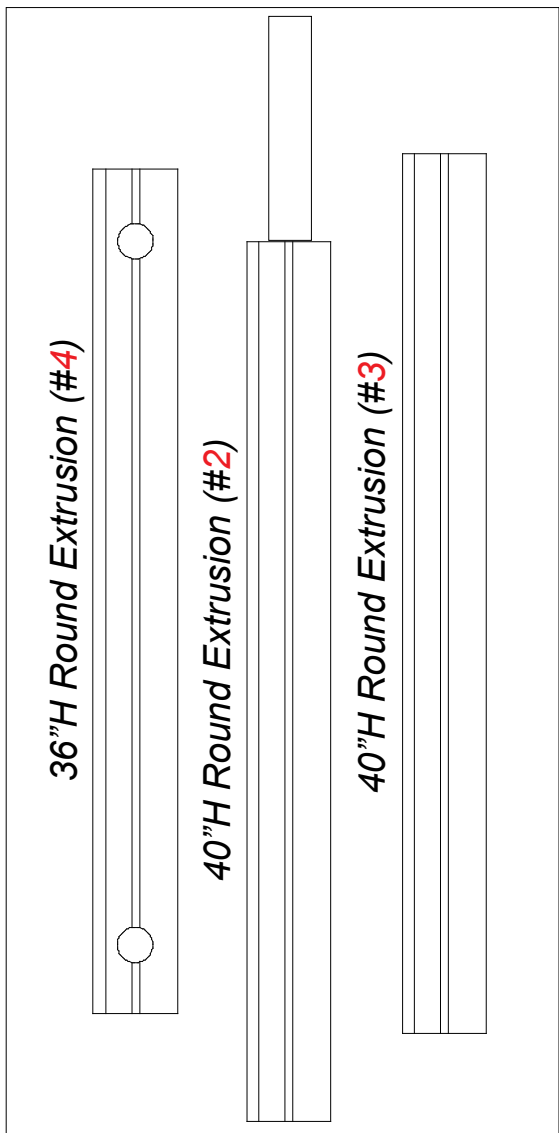

Level 3

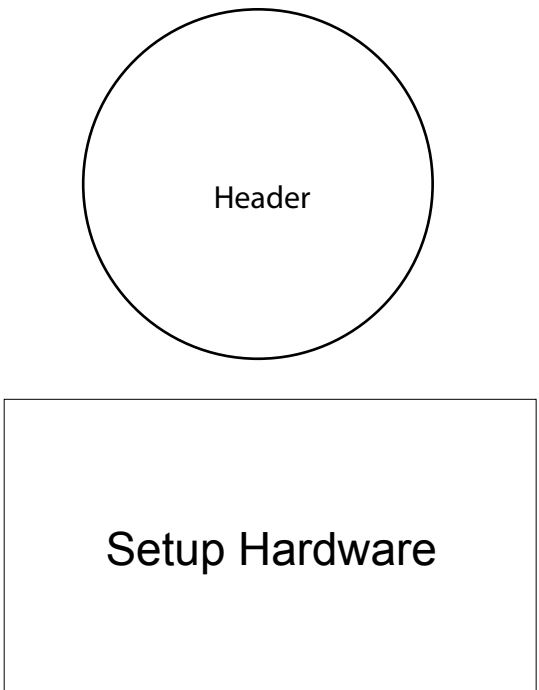

WHEN DISASSEMBLING ALUMINUM EXTRUSION, TIGHTEN ALL SETSCREWS AND LOCKS TO PREVENT LOSS DURING SHIPPING

Top View of each Level

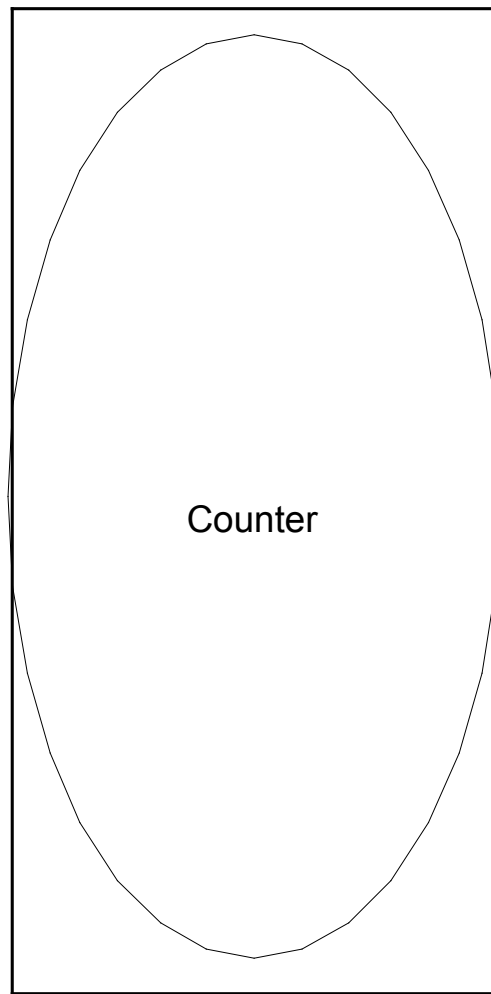

Level 1

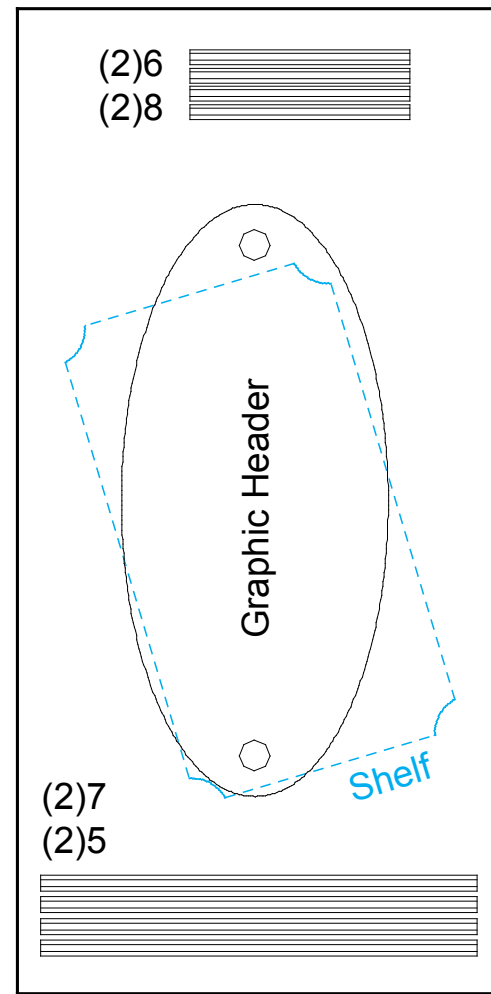

Level 2

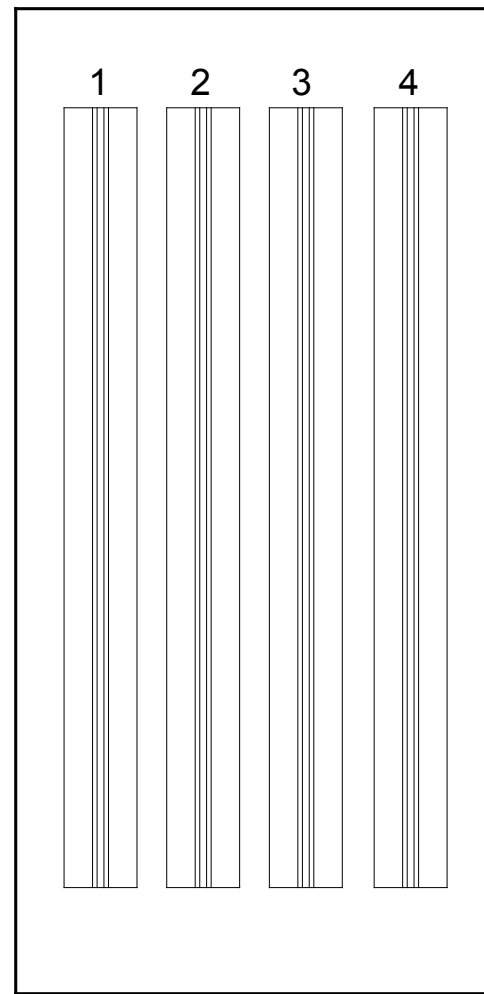

Level 3

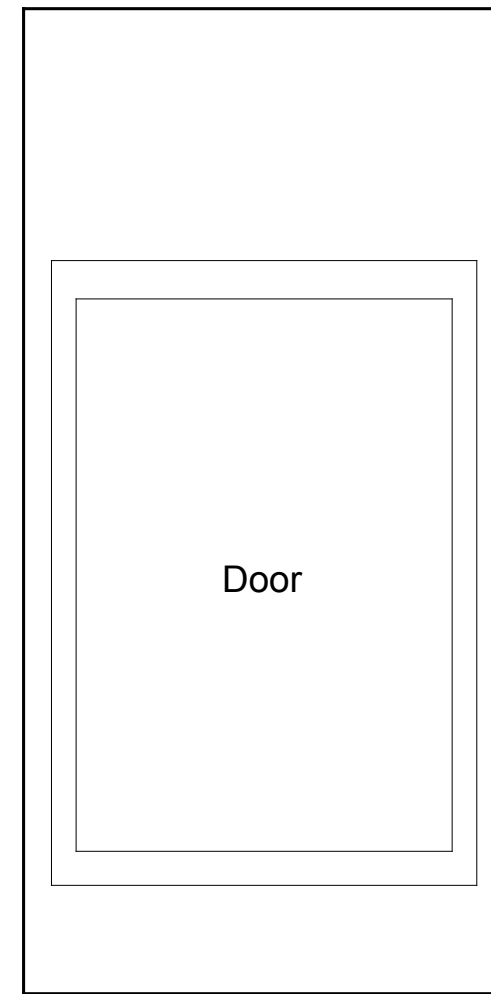

Level 4



WHEN DISASSEMBLING ALUMINUM EXTRUSION, TIGHTEN ALL SETSCREWS AND LOCKS TO PREVENT LOSS DURING SHIPPING