

WHEN DISASSEMBLING ALUMINUM EXTRUSION, TIGHTEN ALL SETSCREWS AND LOCKS TO PREVENT LOSS DURING SHIPPING

# visionary™ IDESIGNS

## Using Your Setup Instructions

The Visionary Designs Setup Instructions are created specifically for your configuration. They are laid out sequentially, including an exploded view of the entire display, and then a logical series of detailed steps to assemble the main structure and components. We encourage you to study the instructions **before** attempting to assemble your exhibit.

Each page reminds you to tighten the setscrews after disassembling your exhibit to prevent loss of the locks and setscrews (see below in RED). This is **VERY IMPORTANT**.

## Cleaning and Packing Your Display

- 1) Use care when cleaning aluminum extrusion or acrylic inserts. Use only non-abrasive cleaners.
- 2) When cleaning laminate inserts or countertops, use mild cleansers and a soft material such as cotton.
- 3) Keep all display components away from extreme heat and long exposure to sunlight to avoid warping and fading.
- 4) Retain all packing material. It will make re-packing much easier and will reduce the likelihood of shipping damage.



**The Tool**

Most Visionary Designs exhibits can be assembled with the supplied Hex Key Tool. Occasionally, a flat head screwdriver may be required.



**Typical Connection**

Most horizontal extrusion connections have a patented expandable lock. This lock inserts into the groove of an opposing extrusion. Tightening the lock with the Hex Key Tool expands the lock and creates a strong positive connection.



**Typical Connection (cont'd)**

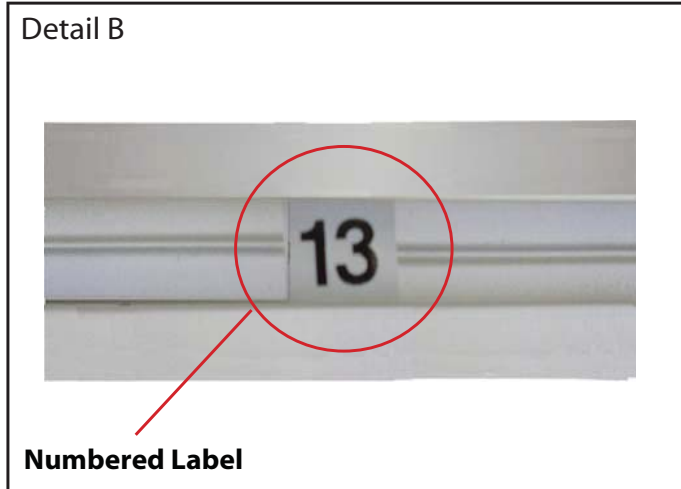

**Detail B**

**Numbered Label**

Each extrusion contains a numbered label which corresponds with setup instructions. The label is located within a groove of the extrusion (when possible). With Visionary Designs the labels contain Black numbers unless otherwise specified.



**Detail C**

**Horizontal Inline Connection** (remove only one setscrew)

Remove only (1) setscrew when disassembling. Replace setscrew in extrusion after assembling it. Before packing, replace setscrew in extrusion to avoid losing it.

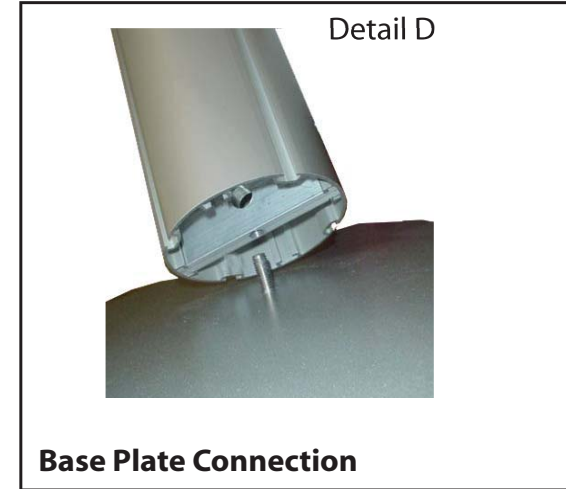

**Detail D**

**Base Plate Connection**

Attach base plate to round or square vertical extrusion using the bolt provided. Be careful not to strip the threads.

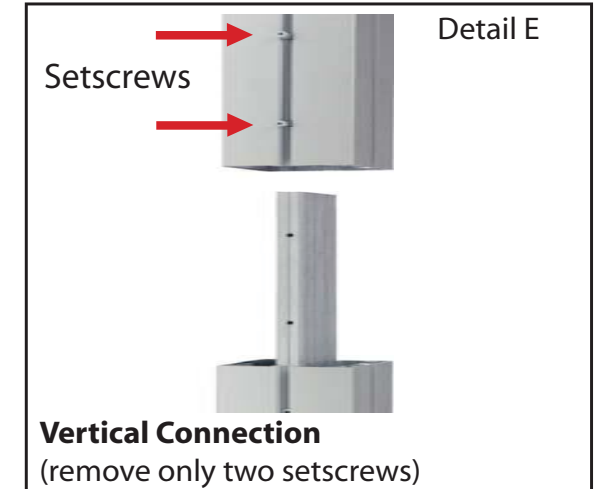

**Detail E**

**Vertical Connection**  
(remove only two setscrews)

When vertical extrusions are packed in portable cases rather than crates or tubs, they must be broken down into smaller sections which then require assembly.

Remove only (2) setscrews when disassembling. Replace setscrews in extrusion after assembling it. Before packing, replace setscrews in extrusion to avoid losing them.

**WHEN DISASSEMBLING ALUMINUM EXTRUSION, TIGHTEN ALL SETSCREWS AND LOCKS TO PREVENT LOSS DURING SHIPPING**

Part Number	Qty for Step	Description
1A	1	10" Square Base Plate
1/1B	3/1	46"h Lower Vertical extrusion
2	4	46"h Upper Vertical extrusion
3	2	46" Lower Horizontal w/ Velcro attached to Top of member
4	2	46" Upper Horizontal w/ Velcro attached to Bottom of member
5	1	10.5" Lower Horizontal Extrusion
6	1	10.5" Upper Horizontal Extrusion

Steps

- 1) Connect lower vertical esxtrusion [1B] to Base plate [1A], refer to Detail D on General info page.
- 2) Connect upper vertical extrusions [2] to lower vertical extrusions [1 and 1B] as shown at right.
- 3) Attach horizontal extrusions [3 and 4] between vertical assemblies [1/2].
- 4) Connect horizontal extrusions [5 and 6] between vertical assemblies [1/2] placing inserts as indicated.

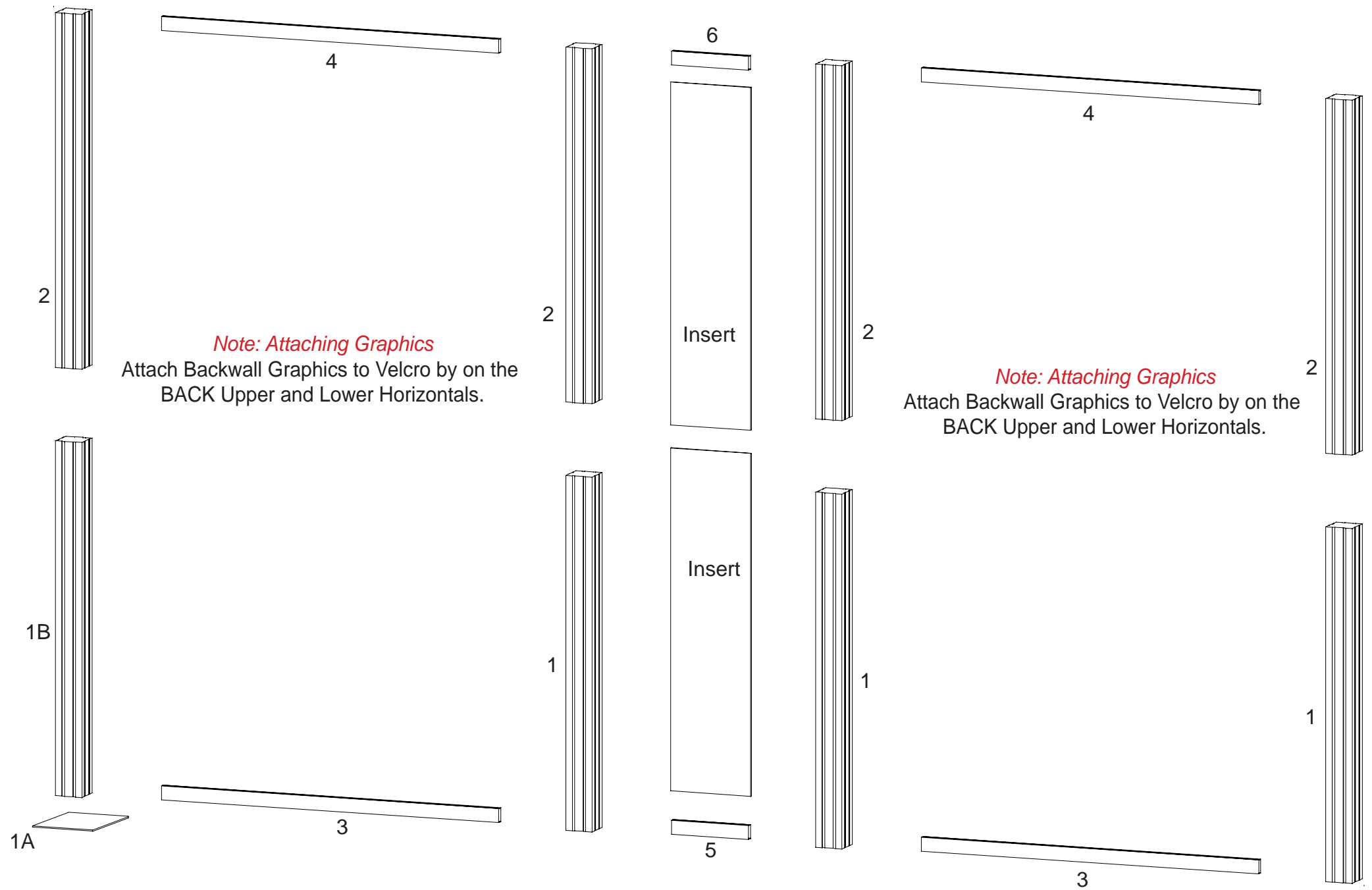

**WHEN DISASSEMBLING ALUMINUM EXTRUSION, TIGHTEN ALL SETSCREWS AND LOCKS TO PREVENT LOSS DURING SHIPPING**

866.652.2100

Part Number	Qty for Step	Description	Steps
7/7A/7B	1/1/1	38" h Vertical extrusion	1) Connect horizontal extrusions [8, 9, and 9A] between vertical extrusions [7, 7A, 7B and 1 (from previous page)].
8	4	27.5" Horizontal	2) Connect horizontal extrusion [10] between vertical extrusion assemblies [1/2 (from previous page)], NOTE: vertical attaches to front groove.
9	2	12.514" Horizontal	3) Attach horizontal extrusions [11] between vertical assemblies [1/2] as shown below, place decorative insert and attach upper horizontal extrusion [11] forming decorative insert to desired Arc.
9A	2	14" Horizontal	
10	1	46" Horizontal	4) Place inserts and door into pedestal as shown in lower right.
11	4	46" Horizontal	5) Attach upper horizontal extrusions [8 and 9] atop inserts and door.
			6) Set Counter atop assembled pedestal.

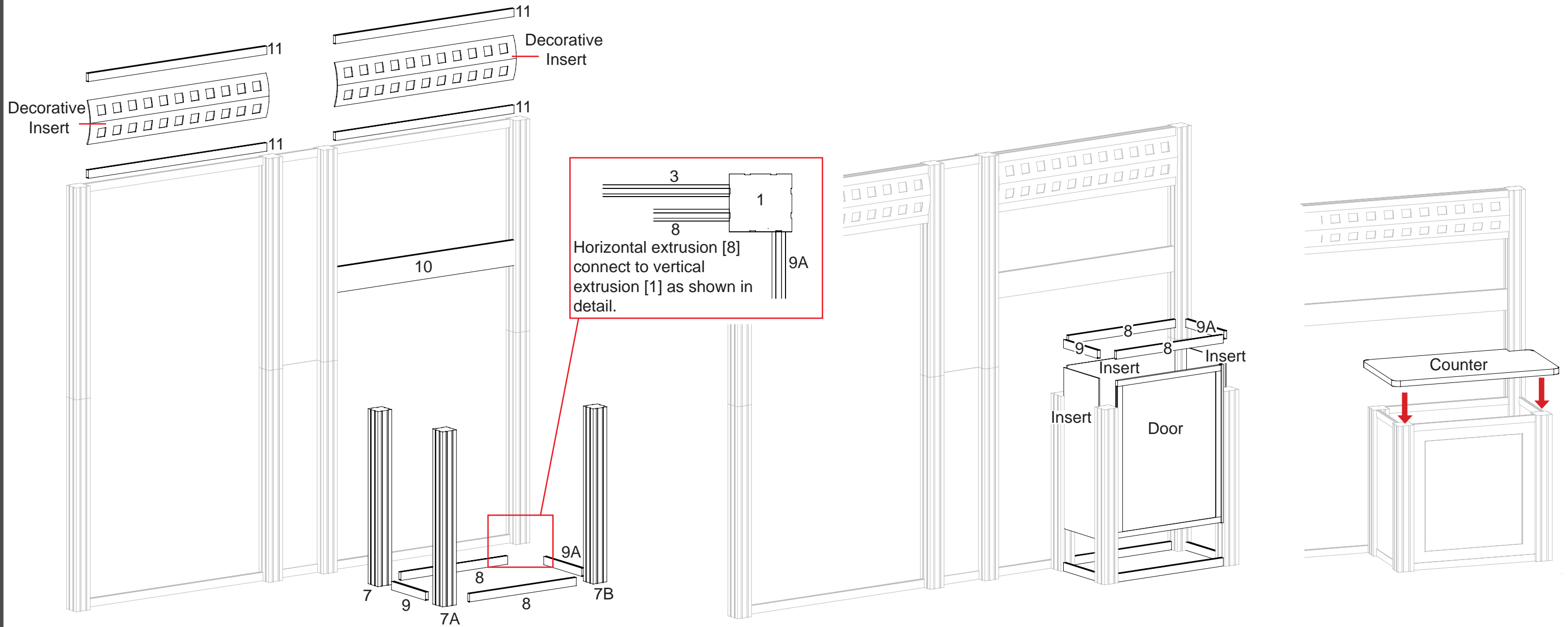

**WHEN DISASSEMBLING ALUMINUM EXTRUSION, TIGHTEN ALL SETSCREWS AND LOCKS TO PREVENT LOSS DURING SHIPPING**

866.652.2100

Part Number	Qty for Step	Description
16	1	Lower Curved Extrusion
17	1	Upper Curved Extrusion
18	1	Lower Curved Extrusion
19	1	Upper Curved Extrusion
20	1	13.791" Horizontal
21	1	13.791" Horizontal
22	1	11" Tapered Horizontal Extrusion
23	1	11" Tapered Horizontal Extrusion
24	1	11" Tapered Horizontal Extrusion
25	1	11" Tapered Horizontal Extrusion
26	1	6" Horizontal Extrusion
27	1	6" Horizontal Extrusion

Steps

- 1) Connect curved extrusions [16 to 17 and 18 to 19].
- 2) Connect curved verticals together using horizontal extrusions [20 and 21].
- 3) Attach assembly [17-21] to backwall using extrusions [22-25] attaching locks into grooves of vertical assemblies [1/2] and pill slot on curved extrusions, placing inserts between as shown.
- 4) Attach decorative header piece to backwall and atop curved assembly using horizontal extrusions [26 and 27].

*Note: Attaching Graphics*  
Attach Graphics to Velcro on the BACK perimeter of Curved assembly.

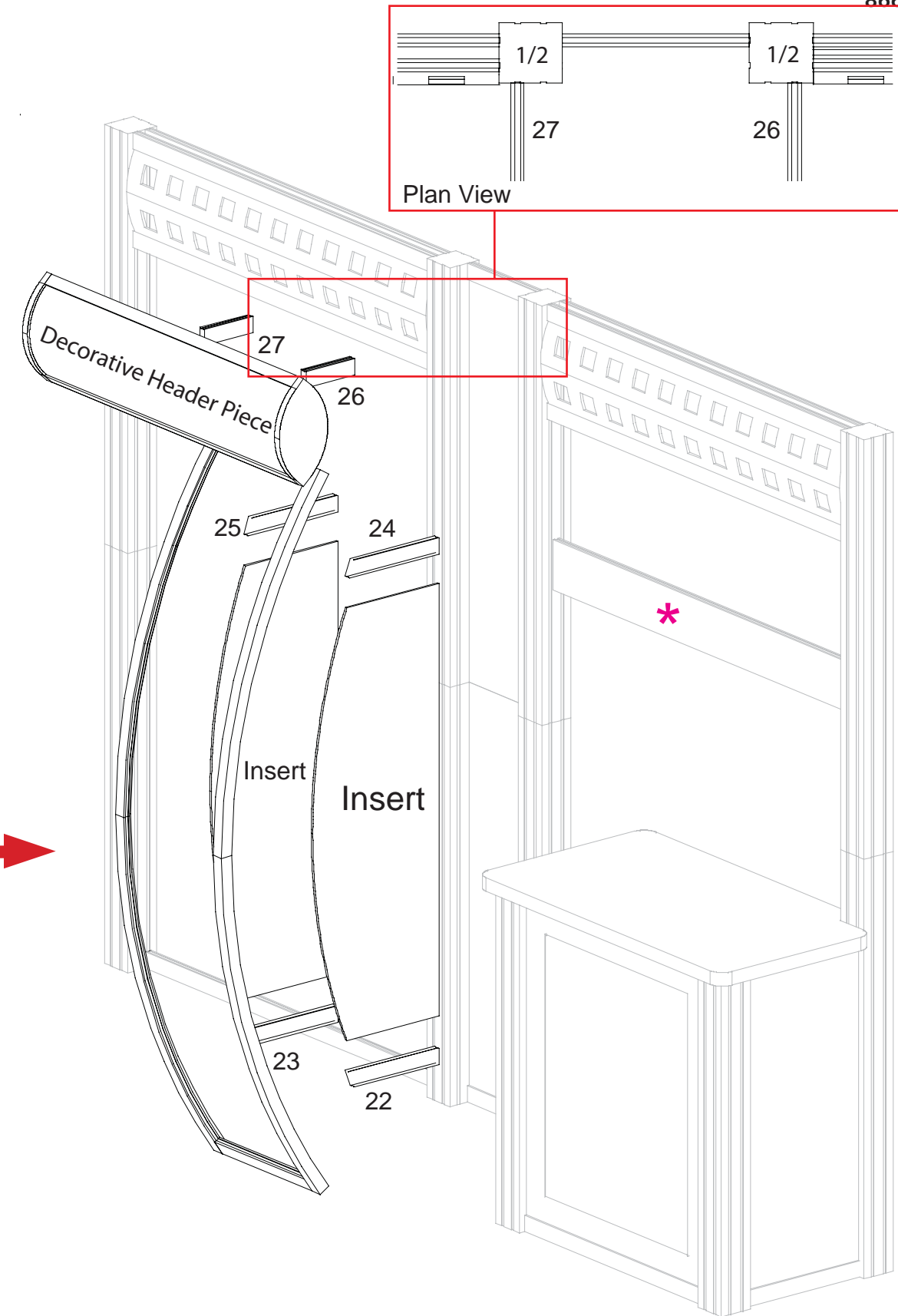
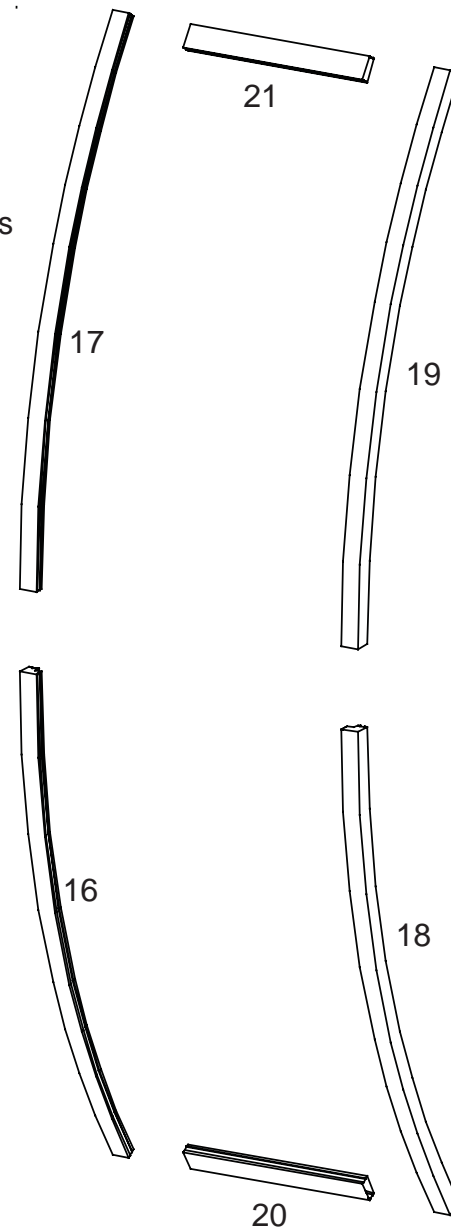

Attach monitor brackets to back of monitor. **\* Monitor Mount Assembly**

Attach wall plate to horizontal extrusion [10] using supplied bolts

Hook monitor brackets over top of wall plate, then secure with safety bolts to bottom of monitor brackets.

**WHEN DISASSEMBLING ALUMINUM EXTRUSION, TIGHTEN ALL SETSCREWS AND LOCKS TO PREVENT LOSS DURING SHIPPING**

Item Number	Description
1	23"w x 42"h Flat Panel w/ Door
2	42"h 90° Corner Connector
3	14.125"w x 42"h Flat Panel
4	42"h 90° Corner Connector w/ Notch for Hook
5	23"w x 42"h Flat Panel
6	42"h 90° Corner Connector w/ Notch for Hook
7	14.125"w x 42"h Flat Panel
8	42"h 90° Corner Connector

Item Number	Description
12	44.423" Formed Extrusion
13	44.423" Formed Extrusion
14	22.23"w Horizontal Extrusion
15	22.23"w Horizontal Extrusion

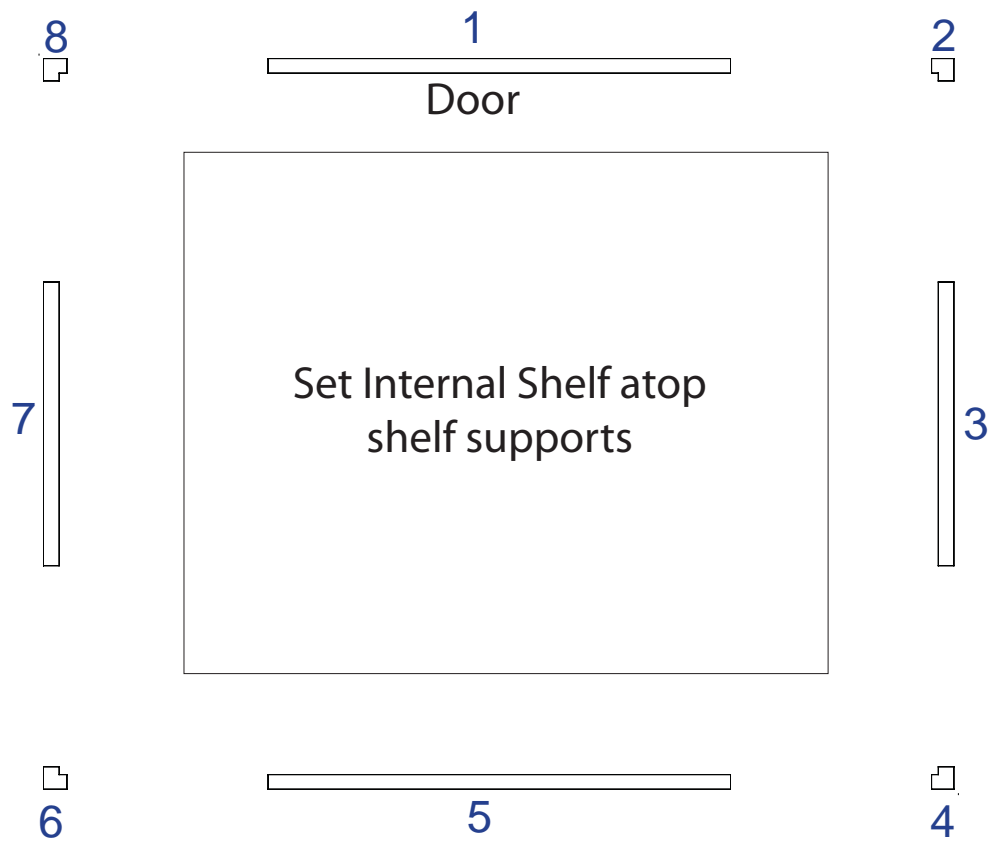

Connect extrusions 12 thru 15 together placing insert as shown in illustration. Then attach hooks to assembled Pedestal.

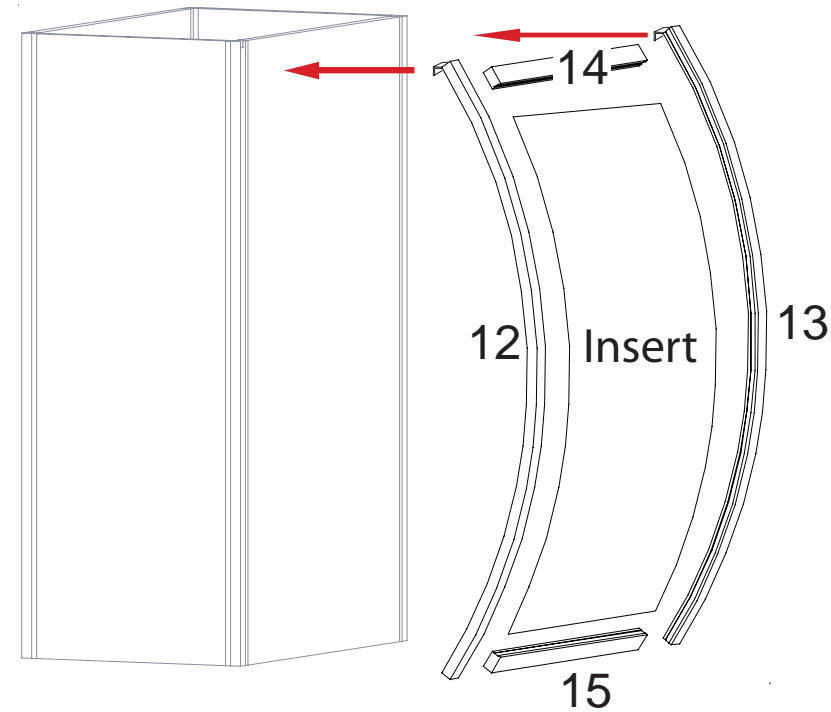

Place Counter atop Assembled Pedestal.

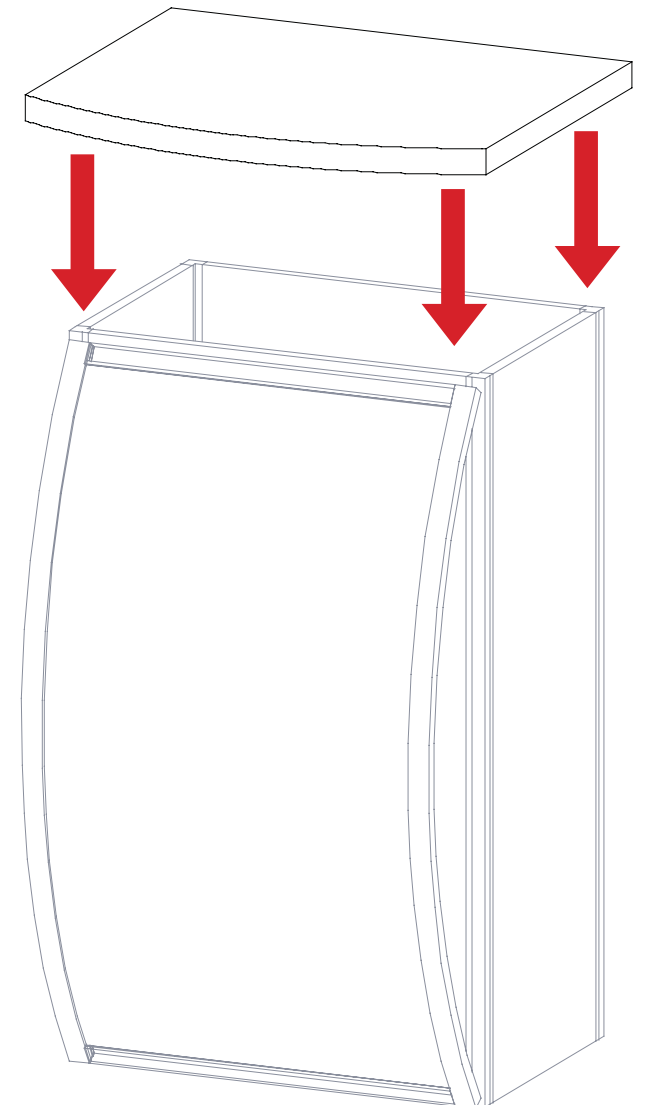

**WHEN DISASSEMBLING ALUMINUM EXTRUSION, TIGHTEN ALL SETSCREWS AND LOCKS TO PREVENT LOSS DURING SHIPPING**



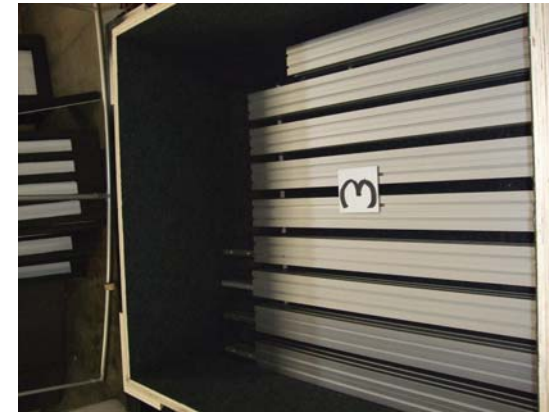
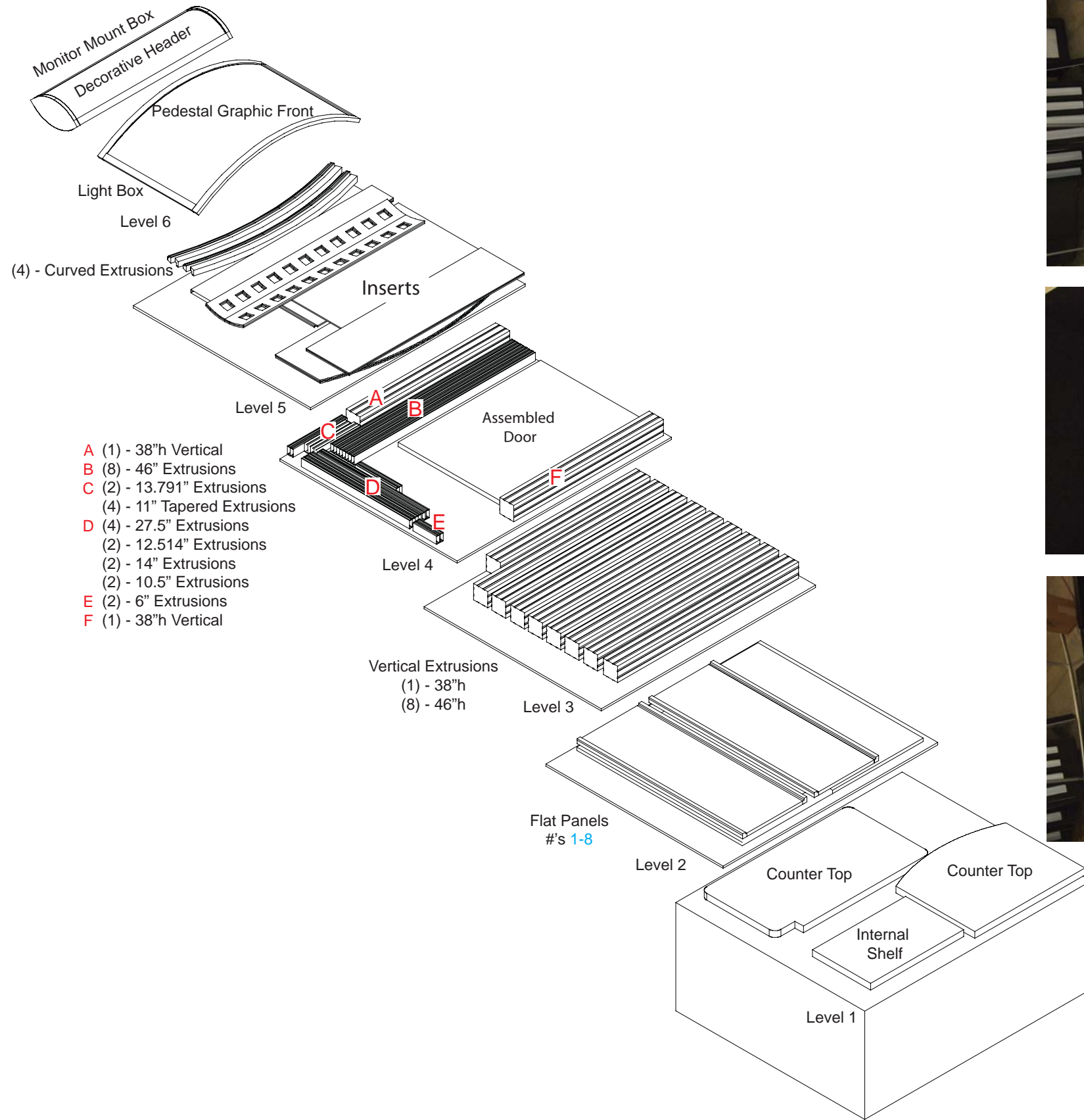

Level 3



Level 6

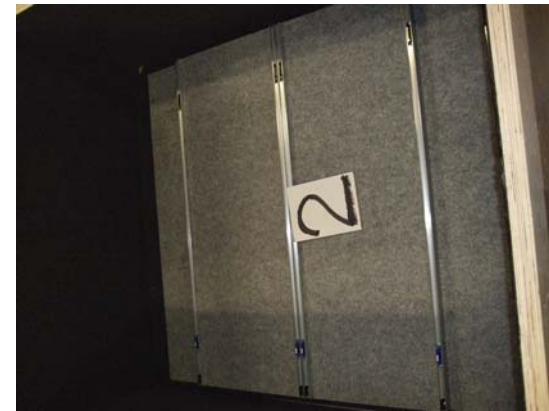

Level 2



Level 5

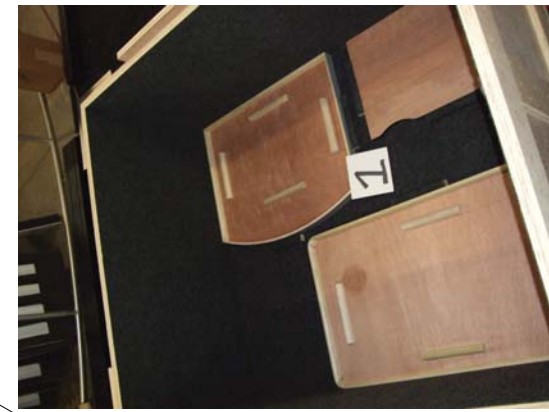

Level 1

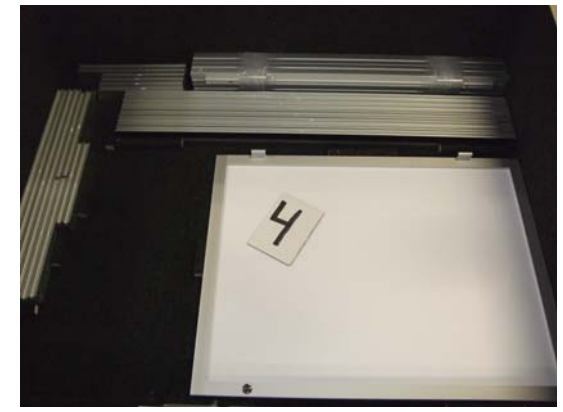

Level 4

**WHEN DISASSEMBLING ALUMINUM EXTRUSION, TIGHTEN ALL SETSCREWS AND LOCKS TO PREVENT LOSS DURING SHIPPING**