

# SACAGAWEA DESIGNS

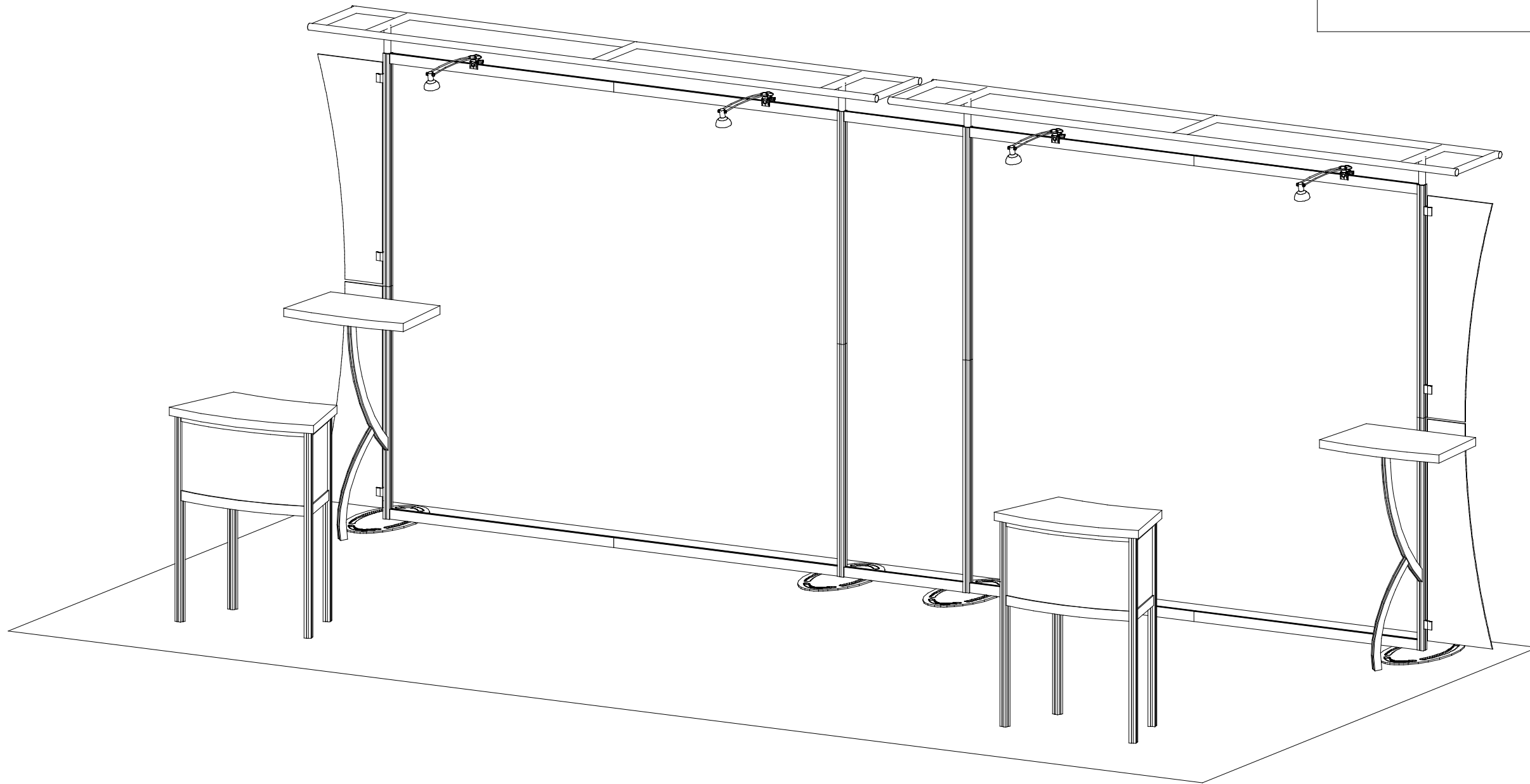
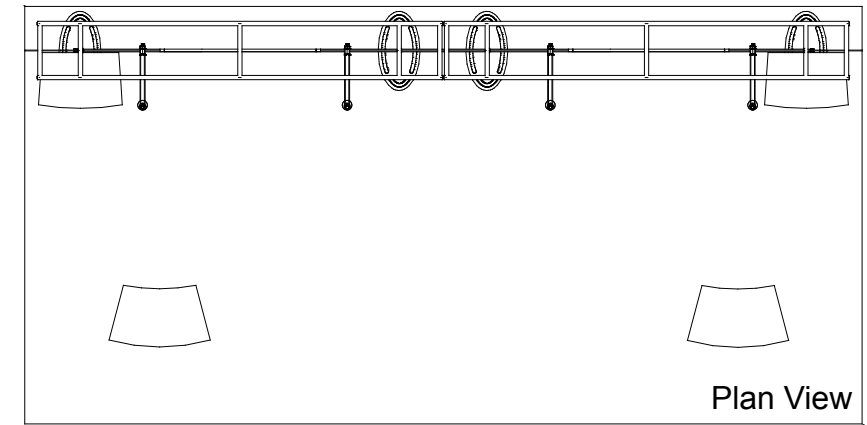

WHEN DISASSEMBLING ALUMINUM EXTRUSION, TIGHTEN ALL SETSCREWS AND LOCKS TO PREVENT LOSS DURING SHIPPING

# SACAGAWEA DESIGNS

## Using Your Set-up Instructions:

The Visionary Designs Set-up Instructions for Sacagawea displays are created specifically for your configuration. They are laid out sequentially, including an exploded view of the entire display and a logical series of detailed steps for assembly. We encourage you to study the instructions **before** attempting to assemble your exhibit.

### THIS IS VERY IMPORTANT!

Each page reminds you to tighten the setscrews after disassembling your exhibit to prevent loss of the locks and setscrews (see below in red).

## Cleaning & Packing Your Display:

- 1) Use care when cleaning aluminum extrusions or acrylic inserts. Use only non-abrasive cleaners.
- 2) When cleaning laminate inserts or counter tops, use mild cleansers and a soft material such as cotton.
- 3) Keep all display components away from extreme heat and long exposure to sunlight to avoid warping and fading.
- 4) Retain all packing materials. It will make re-packing much easier and will reduce the likelihood of shipping damage.

Hex Key Tool



Most visionary design exhibits can be assembled with the supplied Hex Key Tool. Occasionally, a flat head screwdriver may be required.

Typical Connection



**Detail A:** Most horizontal extrusion connections have a patented expandable lock. This lock inserts into the groove of an opposing extrusion. Tightening the lock with the Hex Key Tool expands the lock and creates a strong positive connection.

Typical Connection

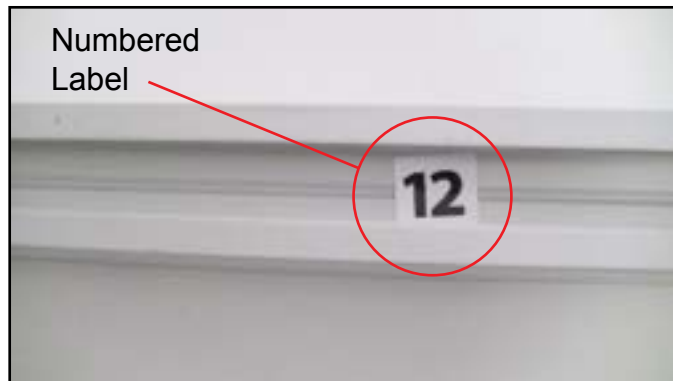

**Detail B:** Each extrusion contains a numbered label that corresponds to set-up instructions. The label is located within a groove of the extrusion (when possible). Visionary Design labels contain Black numbers unless otherwise specified.

Horizontal Connection



**Detail C:** A rectangular connection bar with plastic T Knobs is inserted between two horizontal extrusions joined end-to-end. Turn the knobs clockwise to tighten.

Do Not Overtighten.

Base Plate Connection



**Detail D:** Attach vertical extrusions to base plates with supplied bolts inserted through the hole in the plate. Be careful not to strip the thread.

Vertical Connection



**Detail E:** A square connection bar with plastic T Knobs is inserted between two vertical extrusions joined end-to-end. Turn the knobs clockwise to tighten.

Do Not Overtighten.

Corner Connection



**Detail F:** Plastic Star Knobs are used to tighten locks where horizontal extrusions connect with vertical extrusions. Turn the knobs clockwise to tighten. Turn counter-clockwise to loosen, but do not remove knob.

Do Not Overtighten.

**WHEN DISASSEMBLING ALUMINUM EXTRUSION, TIGHTEN ALL SETSCREWS AND LOCKS TO PREVENT LOSS DURING SHIPPING**

Steps:

- 1) Attach base plates [1] to lower verticals [2a,3a,2c,3c] with bolts.
- 2) Connect upper verticals [2b,3b,2d,3d] to lower verticals [2a,3a,2c,3c] with connection bars [b].
- 3) Connect horizontals [4a,4b] and [5a,5b] with connection bars [a].
- 4) Connect vertical assemblies [2a/2b,3a/3b,2c/2d,3c/3d] with horizontal assemblies [4a/4b,5a/5b] and horizontals [4c,5c] as shown.
- 5) Attach graphics to **velcro** on back side of frame.

Item	Qty.	Description
1	4	Base Plate
2a/2b	1/1	42" Vertical Extrusion w/ A10 Clamps
3a/3b	1/1	42" Vertical Extrusion
2c/2d	1/1	42" Vertical Extrusion
3c/3d	1/1	42" Vertical Extrusion w/ A10 Clamps
4a/4b	1/1	45" Horizontal Extrusion
5a/5b	1/1	45" Horizontal Extrusion
4c/5c	1/1	24" Horizontal Extrusion

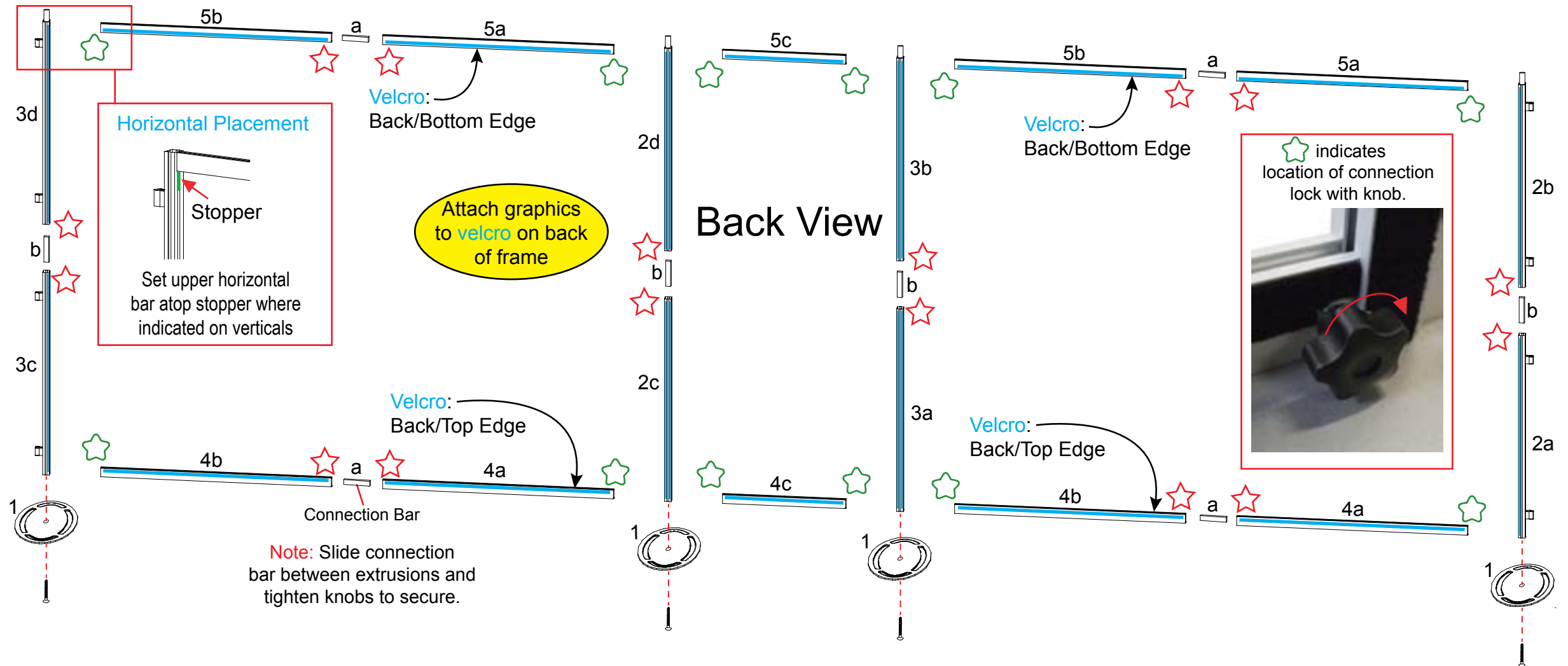
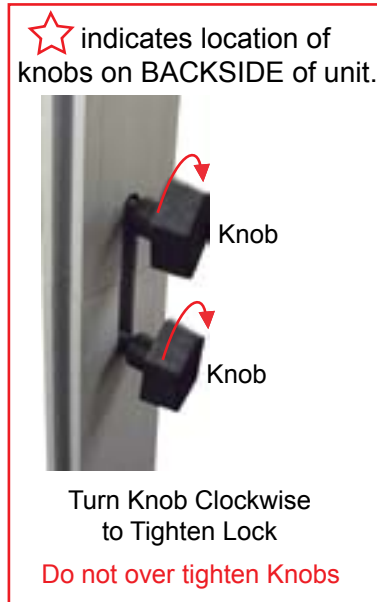
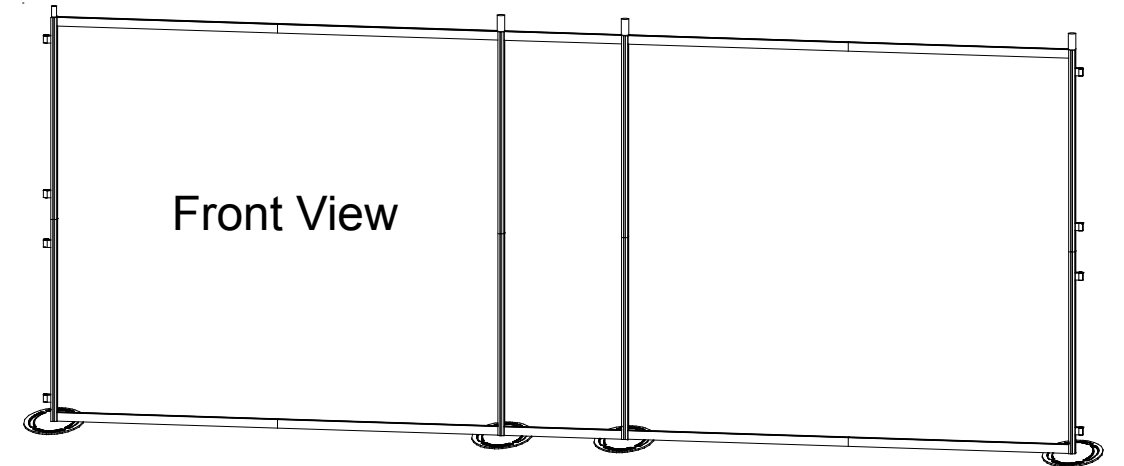

**WHEN DISASSEMBLING ALUMINUM EXTRUSION, TIGHTEN ALL SETSCREWS AND LOCKS TO PREVENT LOSS DURING SHIPPING**

Steps:

- 1) Attach lights as indicated.
- 2) Attach assembled counter supports [10/11] to vertical where indicated.
- 4) Attach support leg [10a] to counter supports [10/11].
- 5) Attach flange plate [11a] to top of curved extrusion [10] as shown.
- 6) Attach counter top to supports, see [counter top attachment](#) detail.
- 7) Attach wings to A10 clamps as shown.
- 8) Attach monitor mount as indicated.

Item	Qty.	Description
10	2	30.2" Curved Extrusion
10a	2	Leg Support
11	2	12.184"w Horizontal Extrusion
11a	2	Flange Plate

\* Monitor Mount Attachment

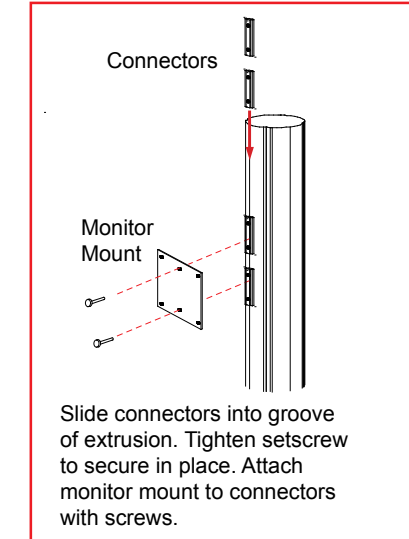

Wing Attachment

Slide A10 Clamp into groove of square extrusion.

A10

When desired location is found, tighten set screw to secure.

Set-Screw

Tighten black plastic set screw to secure Wing in place.

Black Plastic Knob

Keep A10 clamps attached to verticals

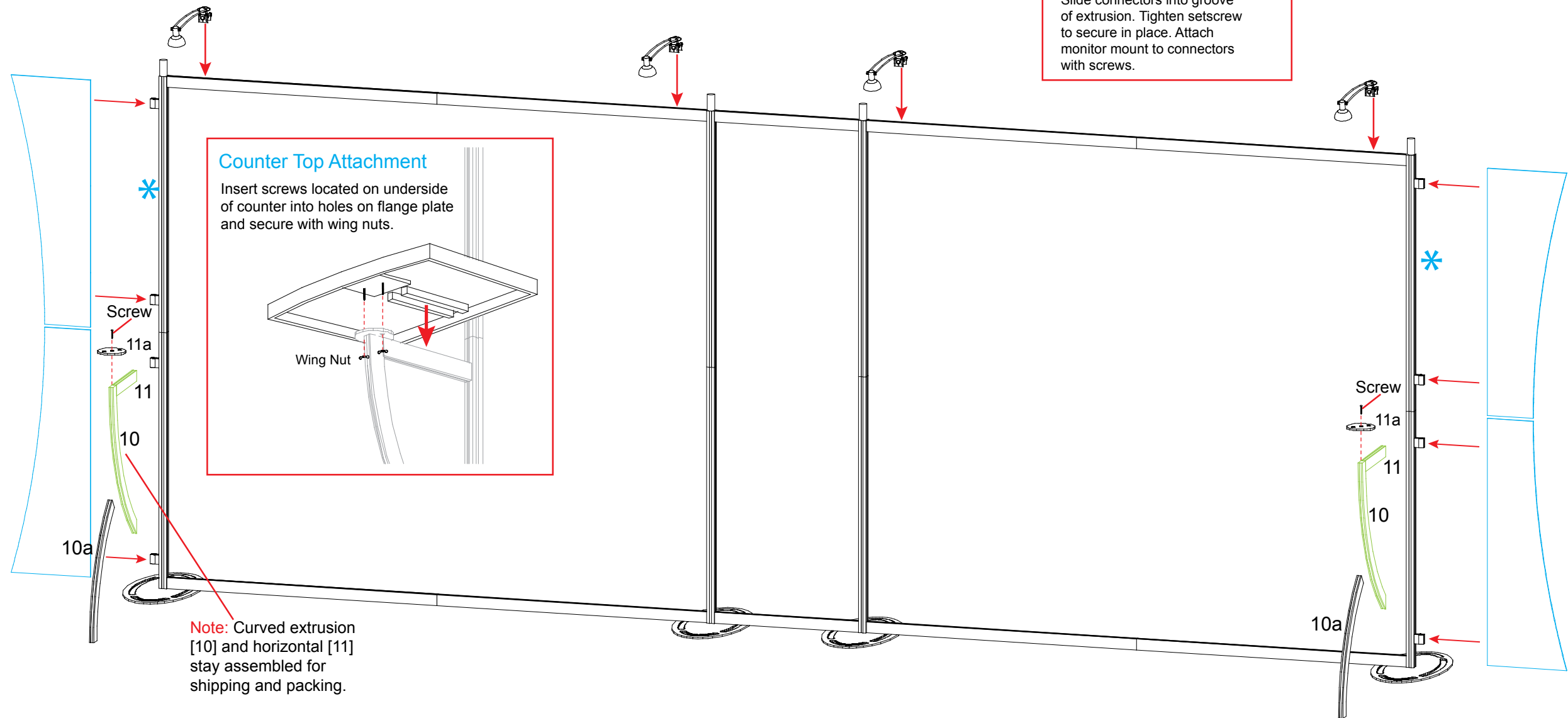

WHEN DISASSEMBLING ALUMINUM EXTRUSION, TIGHTEN ALL SETSCREWS AND LOCKS TO PREVENT LOSS DURING SHIPPING



**Using Your Setup Instructions**

The Aero Overhead Sign Setup Instructions are created specifically for your configuration. They include an exploded view of the frame which is sequentially numbered. We encourage you to study the instructions before attempting to assemble your exhibit.

Connections are kept very simple: no tools. Everything assembles with push-button connectors and pre-connected horizontal sections.

**Cleaning and Packing Your Display**

- 1) Use care when cleaning aluminum extrusion or acrylic inserts. Use only non-abrasive cleaners.
- 2) Retain all packing material. It will make re-packing much easier and will reduce the likelihood of shipping damage.

**Steps:**

- 1) Connect canopy pieces together as shown.
- 2) Apply pillow case graphic to assembled canopy
- 3) Repeat steps for additional canopy.

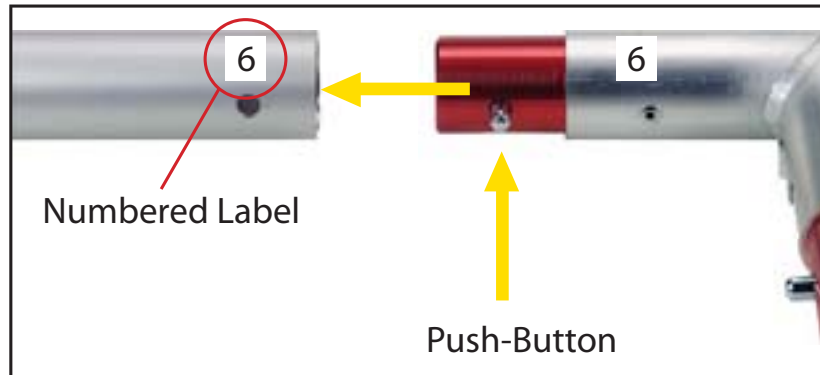
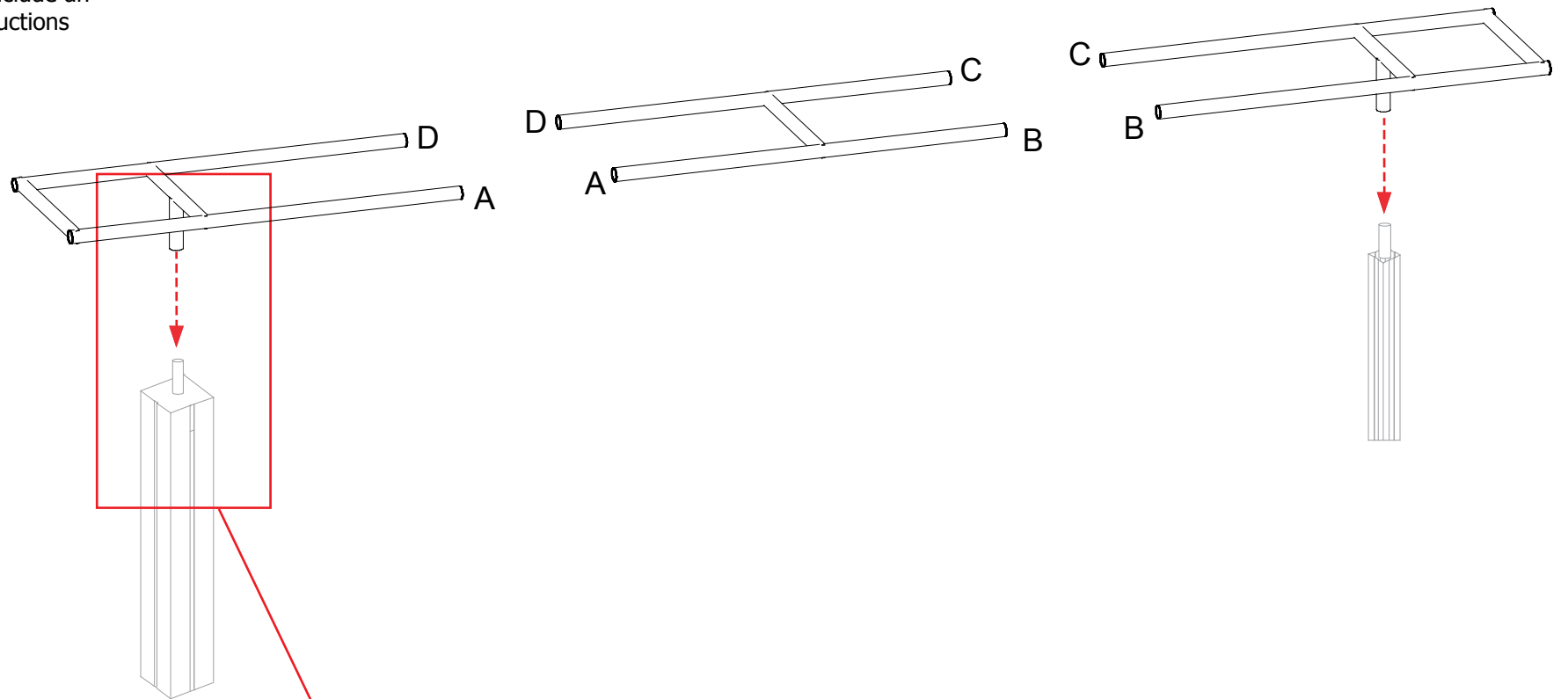

Connections are made by holding the button down and sliding the red tube into opposing tube until the connection is made. To disassemble push button and pull or twist extrusions apart.

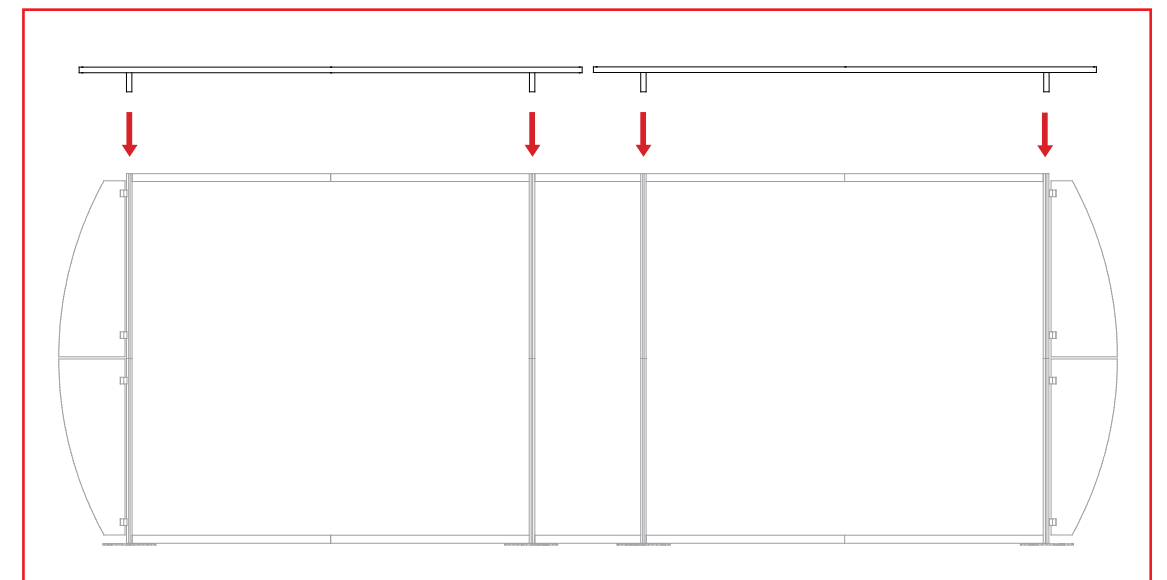
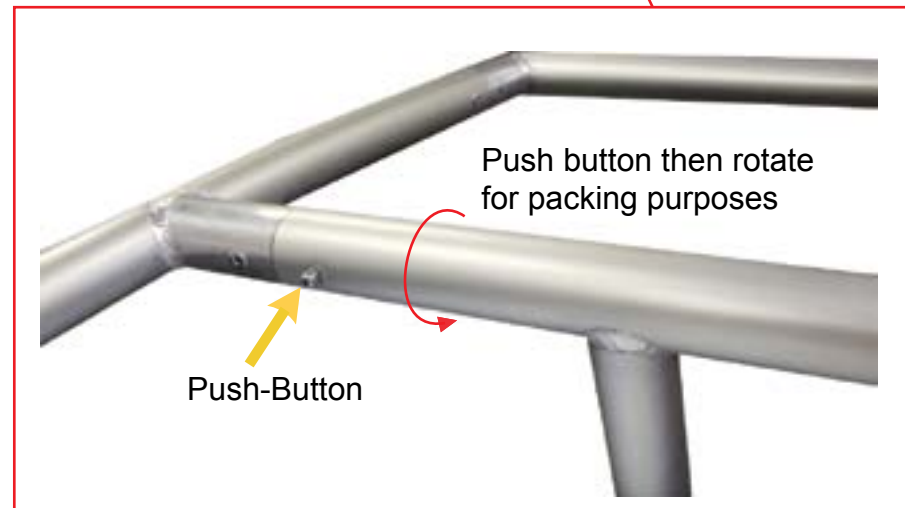
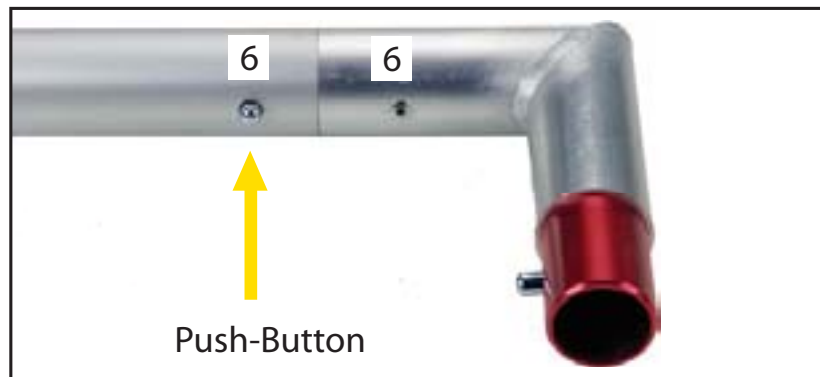

**WHEN DISASSEMBLING ALUMINUM EXTRUSION, TIGHTEN ALL SETSCREWS AND LOCKS TO PREVENT LOSS DURING SHIPPING**



866.652.2100

Item	Qty	Description
12	4	38" h Vertical Extrusion
13/13a	2/2	12" w Horizontal Extrusion
14	2	25" w Horizontal Extrusion

**Steps**

- 1) Attach horizontal extrusions [13 and 13a] between vertical extrusions [12], placing inserts between horizontals.
- 2) Attach curved horizontal extrusions [14] between vertical extrusions [12], placing insert between curved horizontals.
- 3) Place shelf atop lip of extrusions.
- 4) Set counter top atop assembled base.

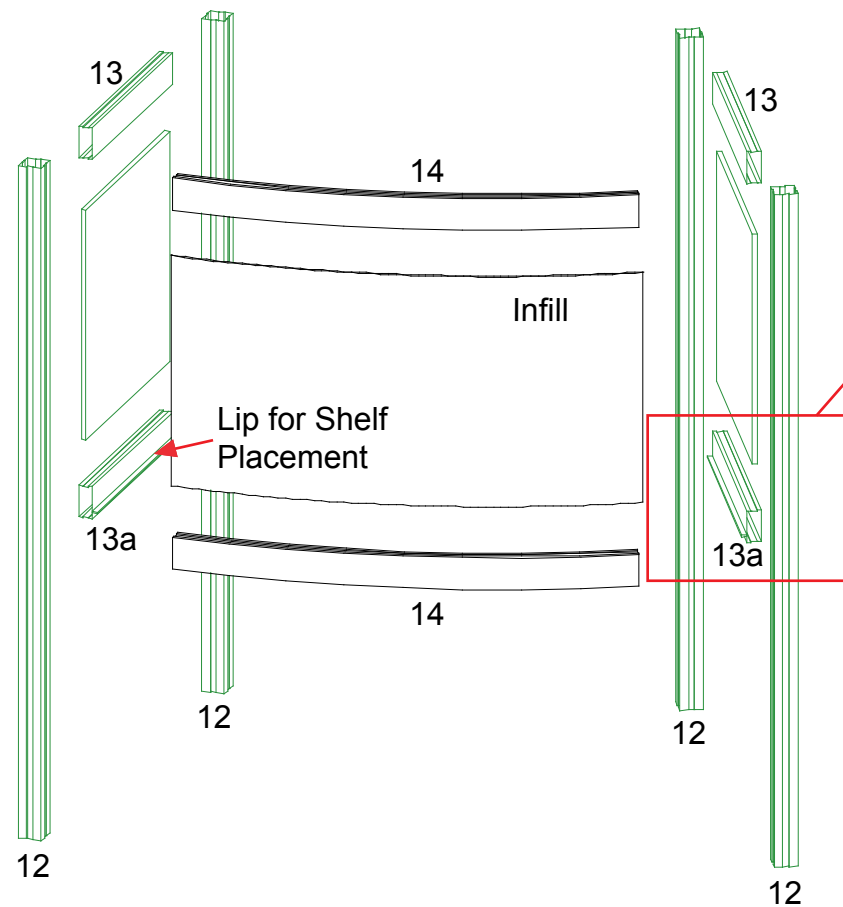
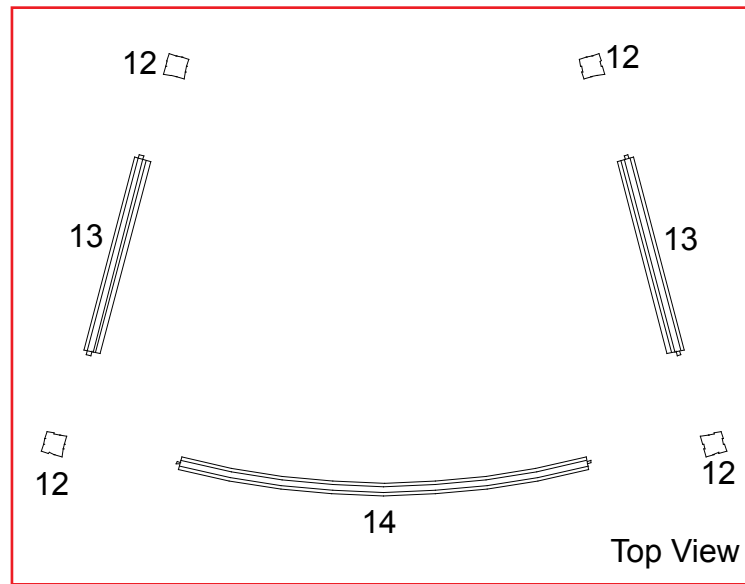

**Extrusion Detail**

Extrusions 13a have a lip for the floor to rest upon.

**Note:** Pedestal sides must stay assembled when shipping

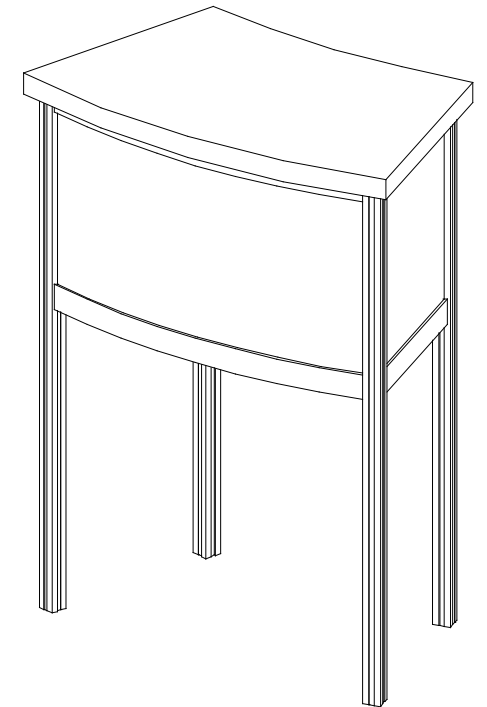
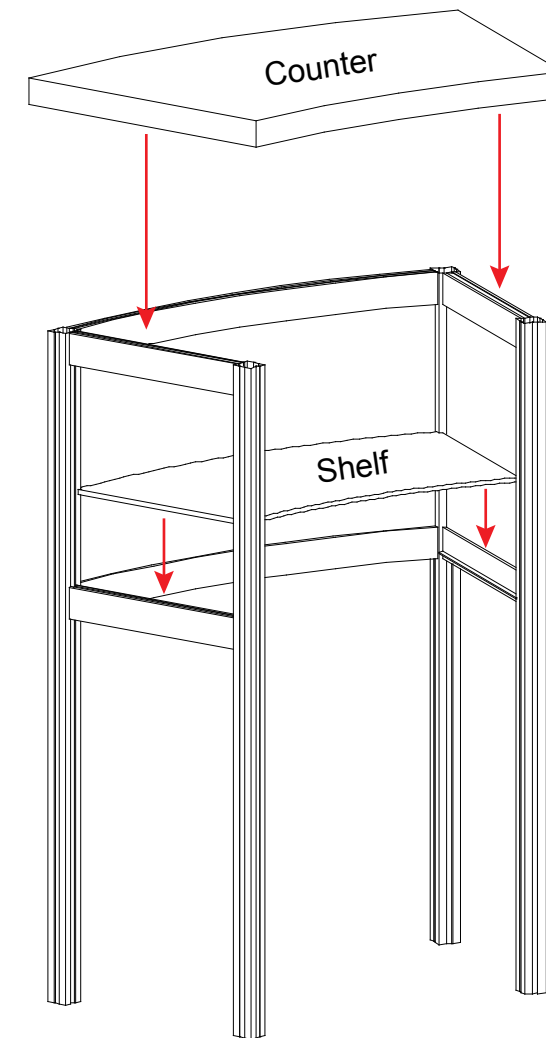

**WHEN DISASSEMBLING ALUMINUM EXTRUSION, TIGHTEN ALL SETSCREWS AND LOCKS TO PREVENT LOSS DURING SHIPPING**

### Top View

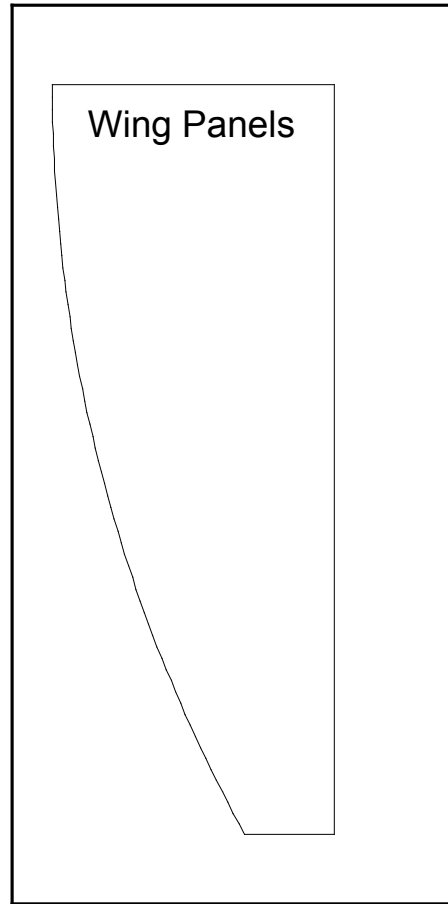

Level 1

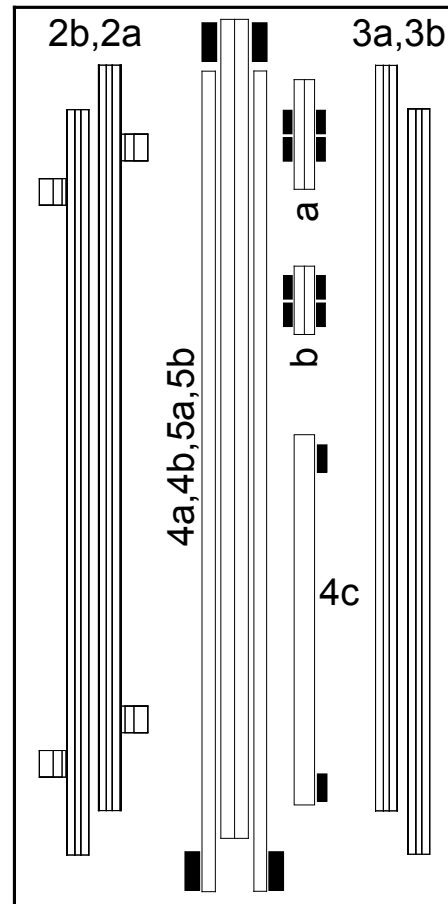

Level 2

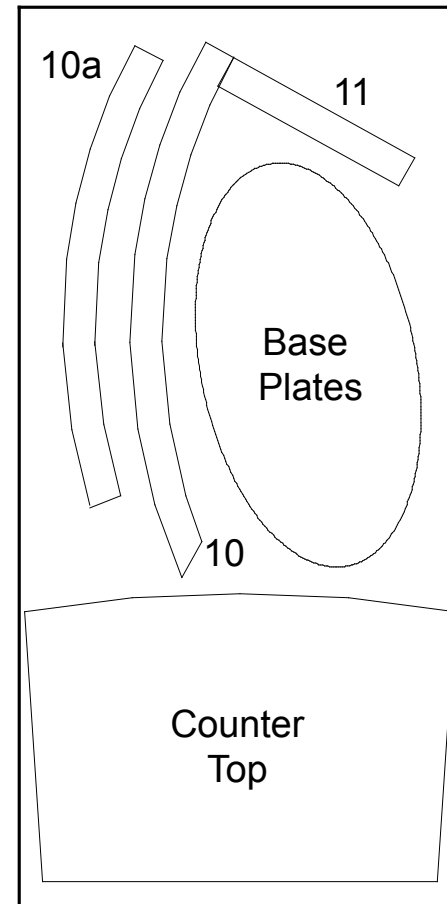

Level 3

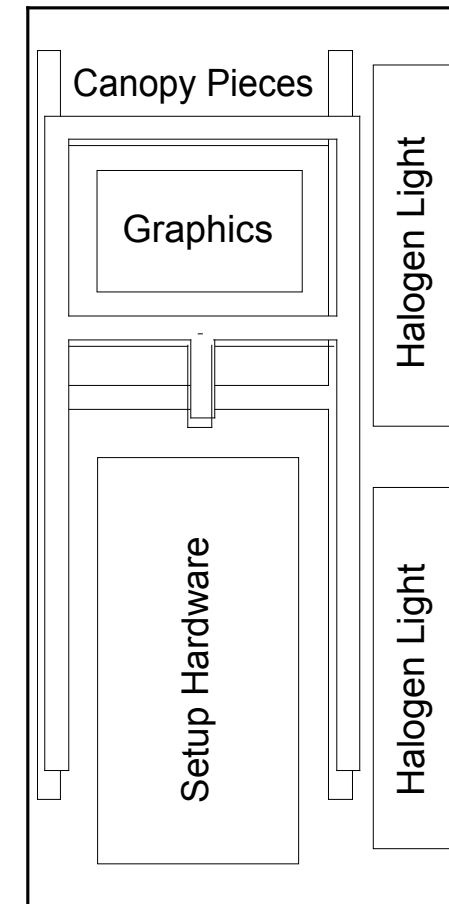

Level 4

WHEN DISASSEMBLING ALUMINUM EXTRUSION, TIGHTEN ALL SETSCREWS AND LOCKS TO PREVENT LOSS DURING SHIPPING

(2) Backwall Components

Top View

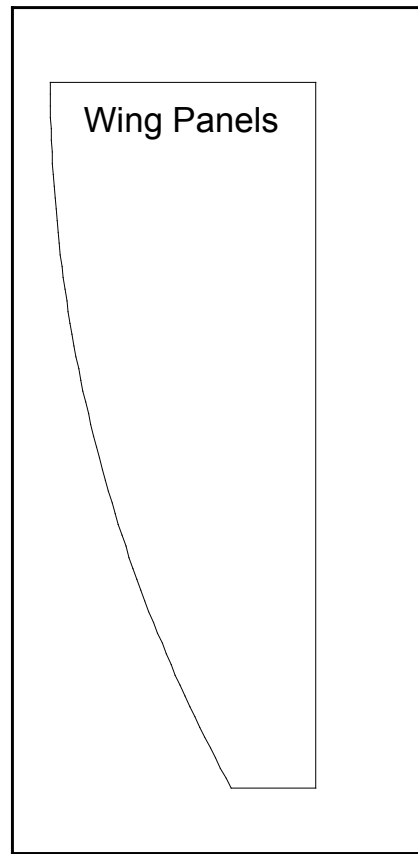

Level 1

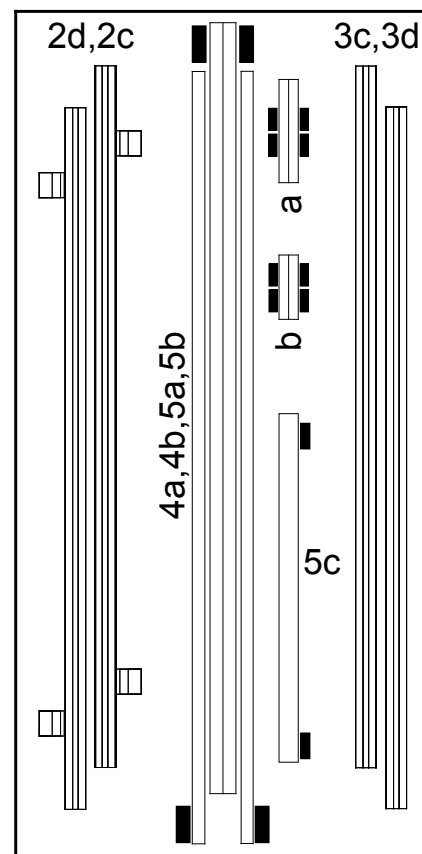

Level 2

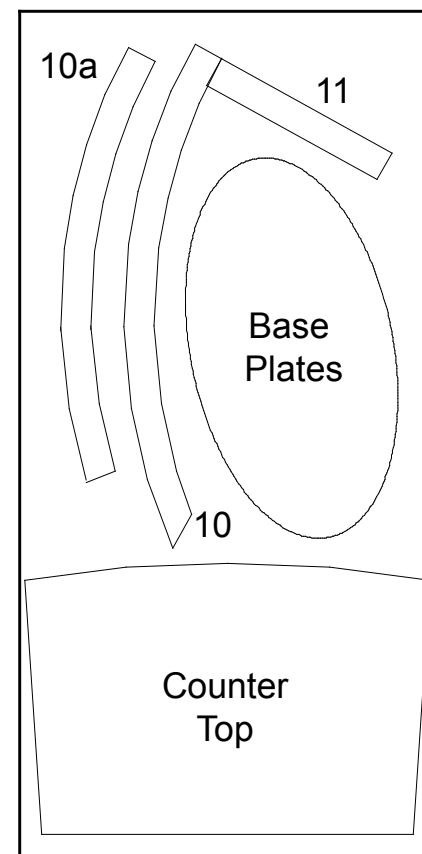

Level 3

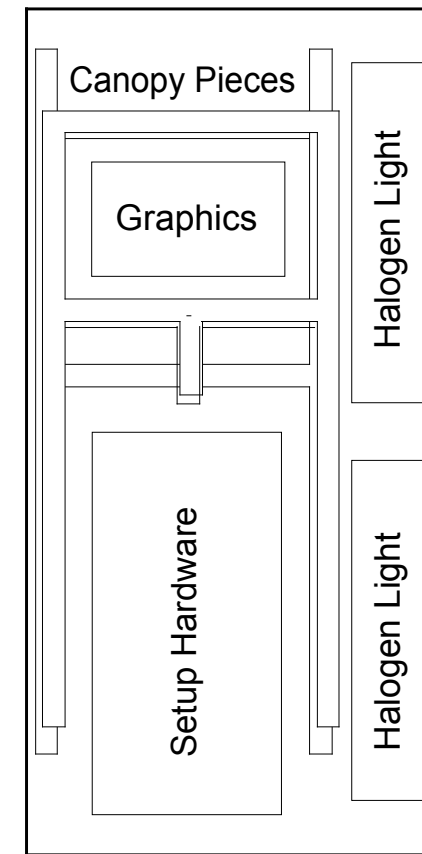

Level 4

WHEN DISASSEMBLING ALUMINUM EXTRUSION, TIGHTEN ALL SETSCREWS AND LOCKS TO PREVENT LOSS DURING SHIPPING



### Top View

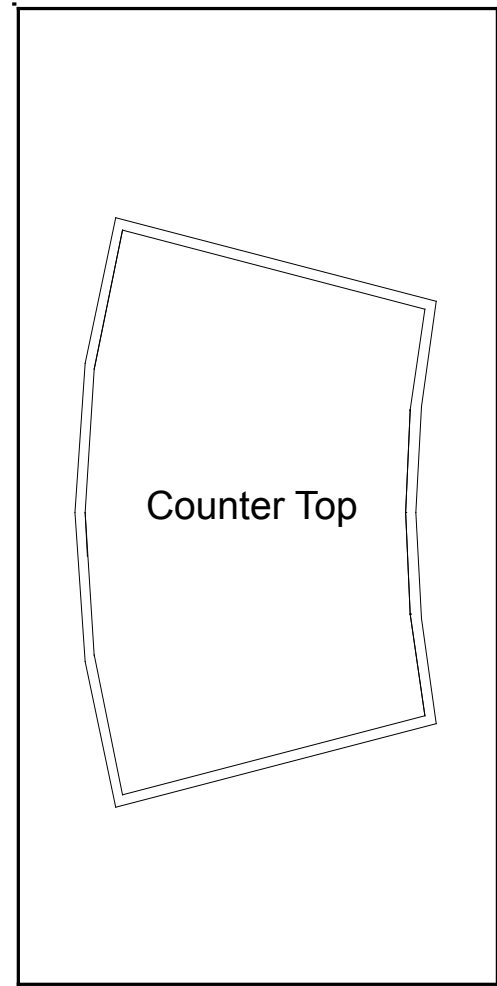

Level 1

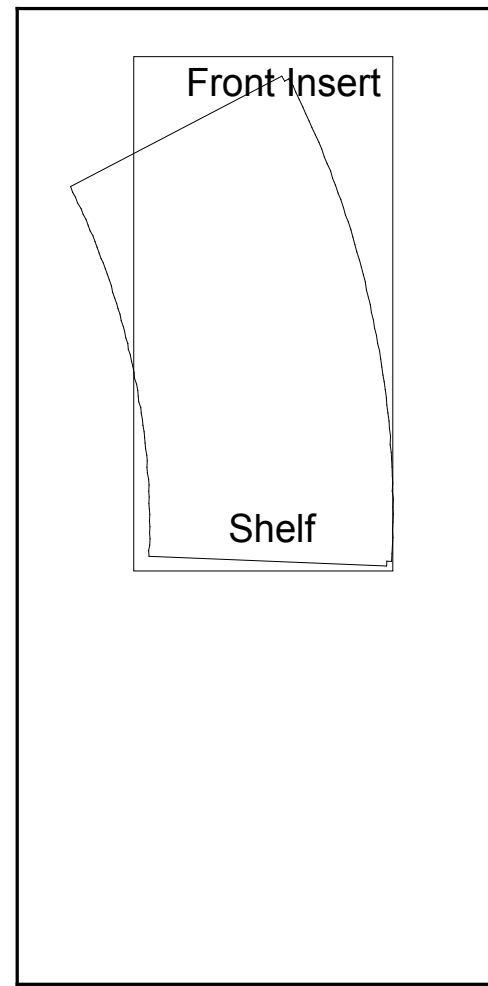

Level 2

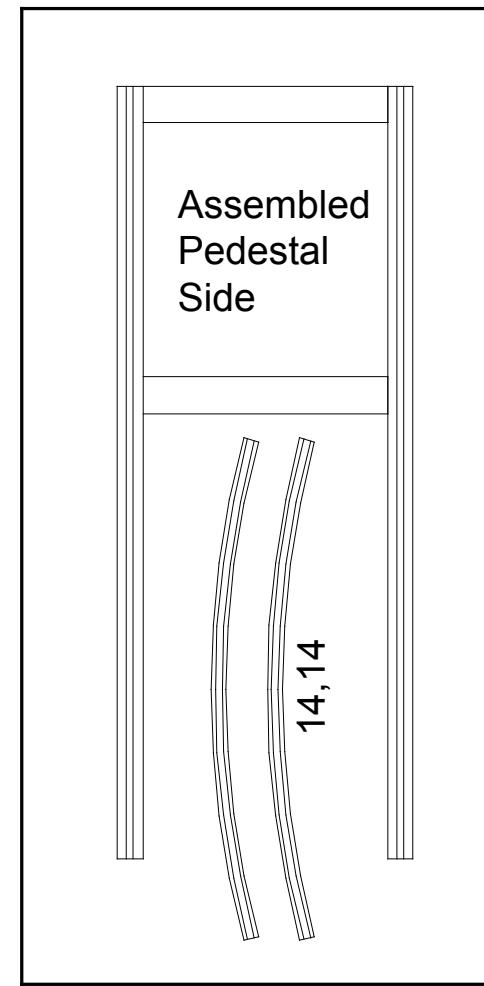

Level 3

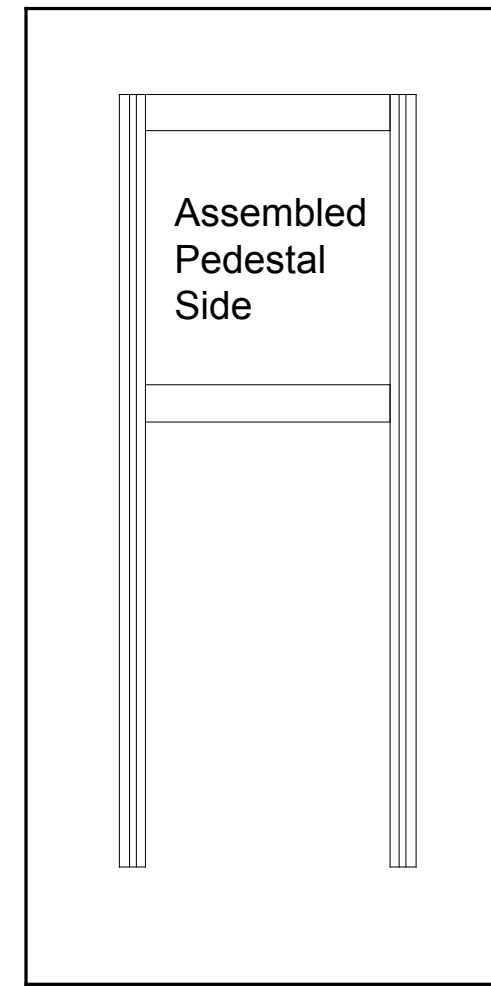

Level 4

WHEN DISASSEMBLING ALUMINUM EXTRUSION, TIGHTEN ALL SETSCREWS AND LOCKS TO PREVENT LOSS DURING SHIPPING

(4) Pedestal Components

Top View

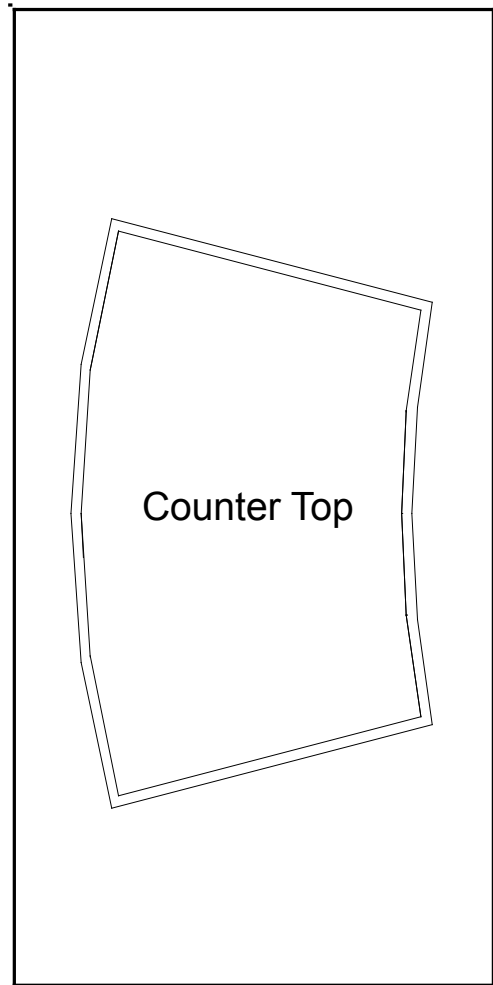

Level 1

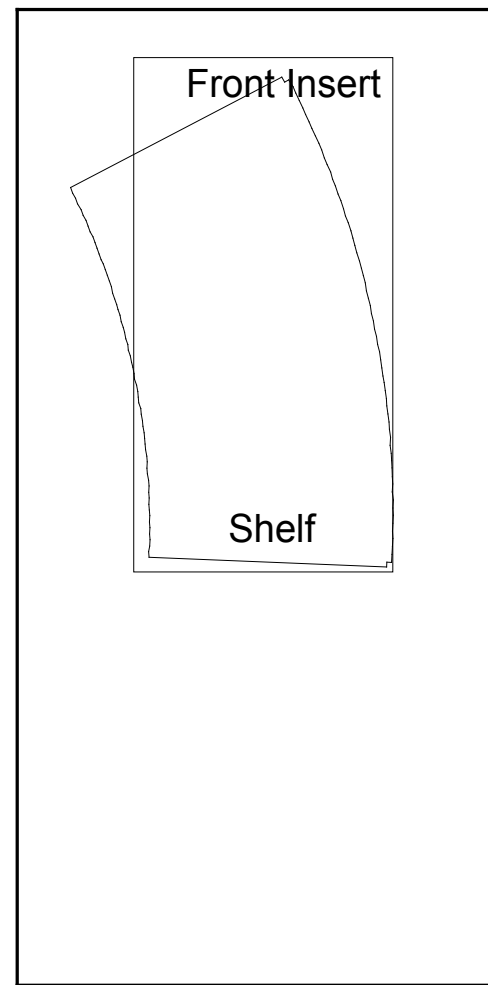

Level 2

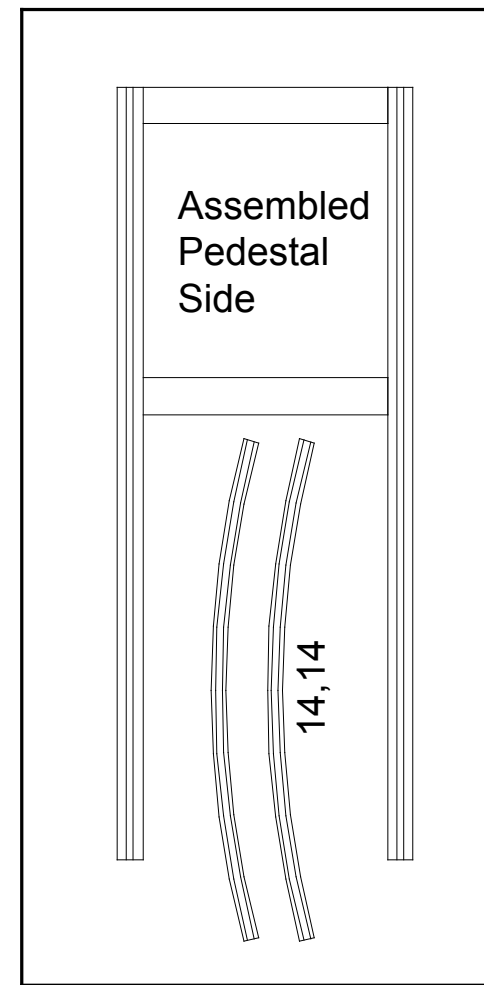

Level 3

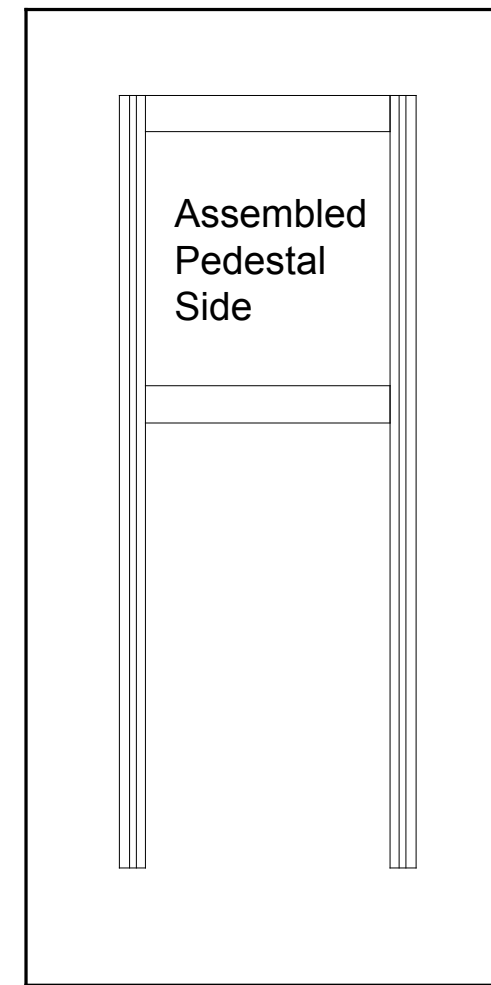

Level 4

WHEN DISASSEMBLING ALUMINUM EXTRUSION, TIGHTEN ALL SETSCREWS AND LOCKS TO PREVENT LOSS DURING SHIPPING